

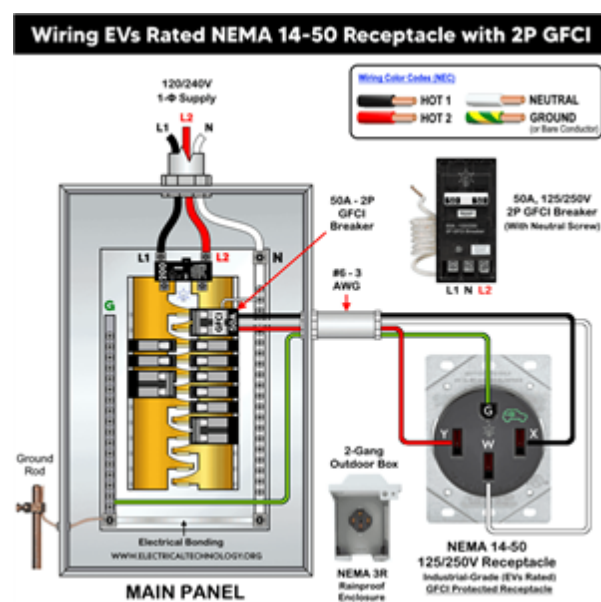

NEC 2023 Practical Application and Compliance Guide



4 PDH

**Professional Development Hours (PDH) or
Continuing Education Hours (CE)
Online PDH or CE course**

2023 National Electrical Code (NEC) – Practical Guide to Requirements in the United States

Author:

Franco F. Davati, P.E. (Texas)

President, DiscountPDH.com

This document is an educational summary and interpretation of selected provisions of the 2023 National Electrical Code (NEC). It is not a substitute for the actual Code. The officially adopted NEC, as published by NFPA, and applicable state and local amendments always govern.

Table of Contents

1. Introduction to the NEC and Its Purpose
 2. 2023 NEC – What’s New and Why It Matters
 3. Scope, Arrangement, and Enforcement of the NEC
 4. Article 90 – Purpose, Scope, and Enforcement Overview
 5. Article 100 – Definitions (Key Terms Every Practitioner Must Know)
 6. Article 110 – General Requirements for Electrical Installations
 7. Grounding and Bonding – Articles 200, 210, 250 Overview
 8. Branch Circuits – Article 210
 9. Feeders and Services – Articles 215 and 230
 10. Overcurrent Protection – Article 240
 11. Wiring Methods – Articles 300, 310, 312, 314, etc.
 12. Cables and Raceways – NM, MC, EMT, PVC, and More
 13. Boxes, Cabinets, Panelboards, and Switchboards
 14. Equipment for General Use – Luminaires, Receptacles, Switches
 15. GFCI and AFCI Protection – Locations and Requirements
 16. Dwelling Units – Selected 2023 NEC Requirements
 17. Commercial and Industrial Facilities – Key NEC Considerations
 18. Special Occupancies – Hazardous Locations, Health Care, Assembly
 19. Special Equipment – Generators, Solar PV, Energy Storage Systems
 20. Ground-Fault and Short-Circuit Calculations (Conceptual)
 21. Working Space, Clearances, and Safety Labelling
 22. Testing, Inspection, and Documentation
 23. Coordination with Building Codes and Other Standards
 24. Common Violations and Field Examples
 25. Summary, Best Practices, and Study Tips
-

1. Introduction to the NEC and Its Purpose

The **National Electrical Code (NEC)**, also known as **NFPA 70**, is the predominant electrical safety code used in the United States for the installation of electrical wiring and equipment. Its central goal is **practical safeguarding of persons and property** from hazards arising from the use of electricity.

While many engineers think of the NEC as a “design manual,” the Code itself is clearer: it is a **minimum safety standard**, not a design handbook or instruction manual for all aspects of engineering design. Designers, engineers, and contractors must use the NEC in conjunction with good engineering practice, manufacturer data, and other standards (IEEE, UL, IEC, etc.).

1.1 NEC Adoption in the United States

In the United States, the NEC is adopted and enforced by:

- **States**
- **Counties / municipalities**
- Sometimes specific **authorities having jurisdiction (AHJs)** such as energy commissions, school districts, or federal facilities.

Not all jurisdictions adopt the same edition at the same time. Many are on the **2020 NEC**, some have moved to **2023**, and a few are still on earlier editions due to legislative and regulatory lag. Always verify:

- Which **edition** is adopted (2017, 2020, 2023)
- What **local amendments** are in force (more restrictive requirements, additional provisions, etc.)

Practice Note: For professional engineers and contractors, it is increasingly important to understand the 2023 NEC because it represents the direction of national best practice, especially with respect to **GFCI/AFCI coverage, emerging energy technologies, and safety around dwelling units and equipment replacement.**

2. 2023 NEC – What’s New and Why It Matters

The 2023 edition of NEC introduces a number of revisions, expansions, and clarifications. While this guide will not reproduce code text, it will emphasize **themes** and **practical effects**.

2.1 Themes in 2023 NEC

- Expanded **GFCI protection** in more locations
- Ongoing refinement of **AFCI requirements**
- More detailed rules for **energy storage systems, renewable energy (PV, wind), and microgrids**
- Updates related to **emerging loads** such as **EV charging**
- Clarifications on **working space**, maintenance, and safety labelling
- Continued adjustment of **conductor ampacity tables**, temperature limitations, and correction factors

2.2 Impact on Practice

For practicing professionals, the 2023 NEC affects:

- **Residential design** – new or expanded locations requiring GFCI/AFCI; receptacle spacing; service and feeder sizing.
 - **Commercial facilities** – updated requirements for feeders, selective coordination, emergency systems, and GFCI usage in non-dwelling areas.
 - **Industrial and special systems** – ESS, PV, rapid shutdown, and interconnection requirements.
-

3. Scope, Arrangement, and Enforcement of the NEC

The NEC is arranged in **Chapters, Articles, Parts, and Sections**.

- **Chapter 1:** General
- **Chapter 2:** Wiring and Protection
- **Chapter 3:** Wiring Methods and Materials
- **Chapter 4:** Equipment for General Use
- **Chapter 5:** Special Occupancies
- **Chapter 6:** Special Equipment
- **Chapter 7:** Special Conditions
- **Chapter 8:** Communications Systems
- **Chapter 9:** Tables

Articles are the main building blocks, each addressing a specific topic (e.g., Article 210 – Branch Circuits, Article 250 – Grounding and Bonding).

Diagram Placeholder – Figure 1

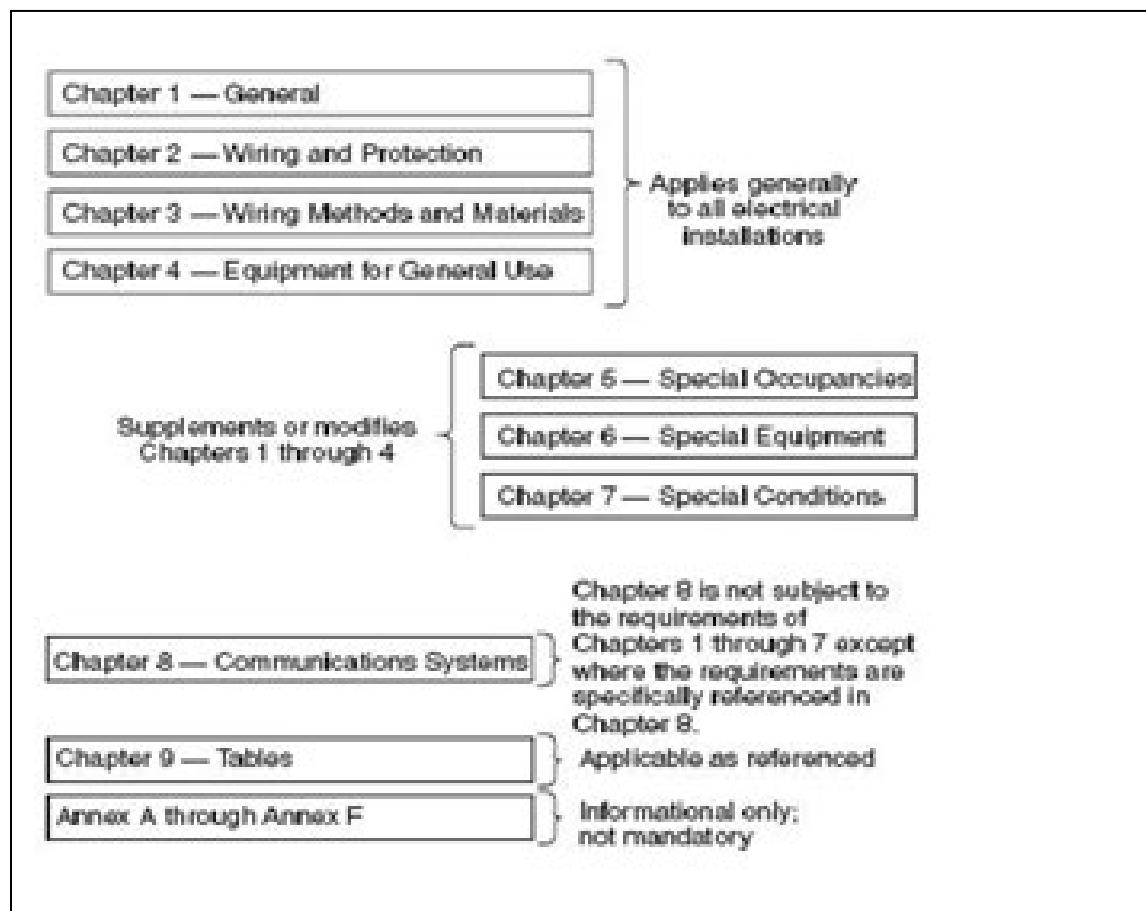

“NEC Structure Overview”

- A block diagram showing:
 - Chapter 1 → Articles 90, 100, 110
 - Chapter 2 → Articles 200, 210, 215, 220, 225, 230, 240, 242, 250, etc.
 - Chapter 3 → Articles 300–398
 - Etc.

4. Article 90 – Purpose, Scope, and Enforcement Overview

Article 90 sets the foundation for how the NEC is to be used.

4.1 Purpose

The NEC is intended to provide **practical safeguarding** of persons and property from hazards arising from the use of electricity. It is **not**:

- A design specification catalog

- An instruction manual for untrained persons
- A guarantee of efficient, convenient, or adequate electrical service

4.2 Scope

The Code covers:

- **Installation** of electrical conductors, equipment, and raceways;
- **Signaling and communications** conductors and equipment;
- **Optical fiber cables** and raceways.

It applies to public and private premises, including residences, commercial buildings, industrial plants, and certain utility installations not under exclusive utility control (depending on jurisdiction).

4.3 Enforcement and AHJ

The **Authority Having Jurisdiction (AHJ)** is the entity legally responsible for interpreting, enforcing, and approving equipment, installations, and materials. This could be:

- City building department
- State electrical board
- Fire marshal
- Federal agency, etc.

Practical Point: Professional engineers should design with enough **margin and clarity** that the AHJ's review proceeds smoothly. Clear single-line diagrams, load calculations, panel schedules, and specifications strongly reduce field conflict.

5. Article 100 – Definitions (Key Terms Every Practitioner Must Know)

Article 100 defines terms used throughout the NEC. The 2020 and 2023 editions reorganized many definitions by theme (e.g., **General, Non-dwelling, Dwelling Units, Grounding and Bonding**, etc.).

Key concepts include:

- **Accessible vs Readily Accessible**
- **Approved** (as determined by the AHJ)
- **Bonding vs Grounding**
- **Ground-Fault, Short-Circuit, Overcurrent**
- **Service, Feeder, Branch Circuit**
- **Intersystem Bonding Termination, Equipment Grounding Conductor (EGC), Grounding Electrode Conductor (GEC)**

Diagram Placeholder – Figure 2

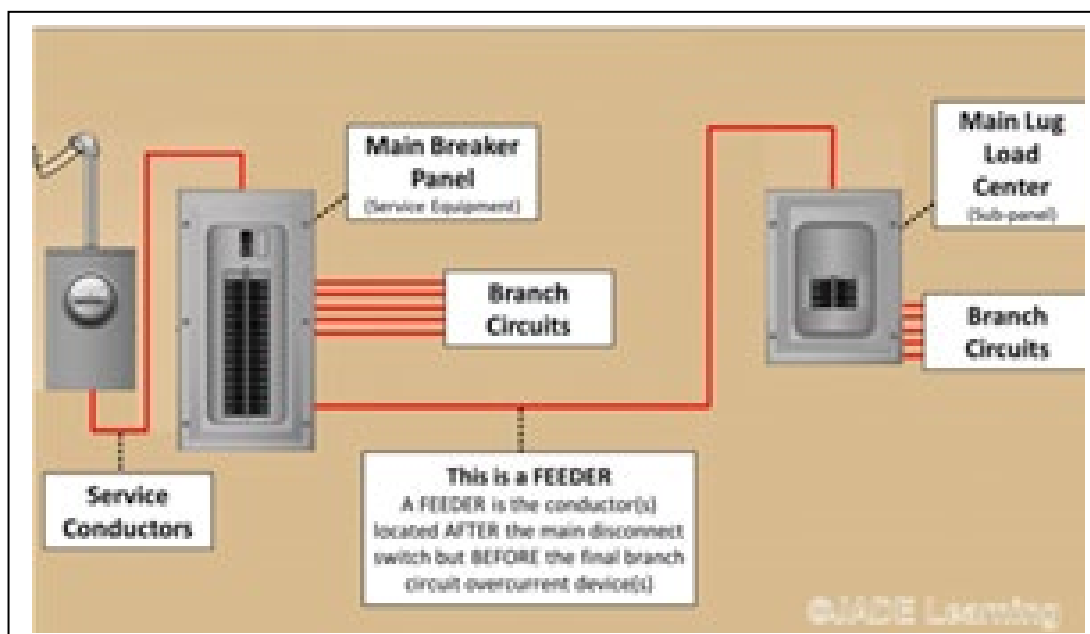
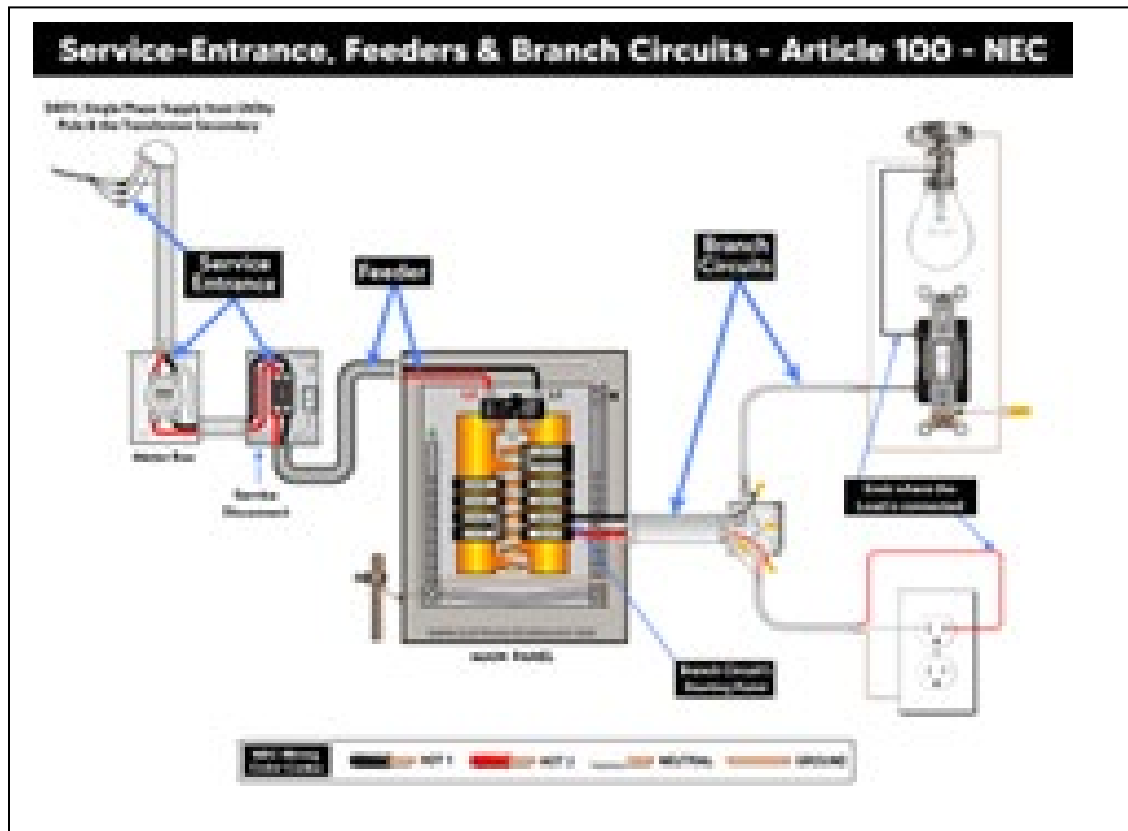

“Service, Feeder, and Branch Circuit Relationship”

- A simple one-line diagram showing:

- Utility transformer → service point → service disconnect → panelboard → feeders → subpanels → branch circuits → loads.
-

6. Article 110 – General Requirements for Electrical Installations

Article 110 is the heart of **general installation rules** and exam questions.

6.1 Approval and Listing

- Equipment must be **listed** and **labeled** for the specific purpose where required by the NEC.
- Listed products are generally evaluated by recognized testing laboratories (e.g., UL, ETL).

6.2 Installation and Use

- Equipment shall be installed and used in accordance with its **listing and labeling instructions**.
- Manufacturer's instructions are integral to compliance.

6.3 Working Space and Accessibility

Working space around electrical equipment is crucial for safe operation and maintenance. The NEC specifies:

- **Depth of working space** based on nominal voltage to ground and equipment conditions (e.g., live parts on one side vs both sides).
- **Width** of working space (often the width of the equipment or a minimum value, whichever is greater).
- **Height** of working space (often extending from the grade/floor to a specified height).

Diagram Placeholder – Figure 3

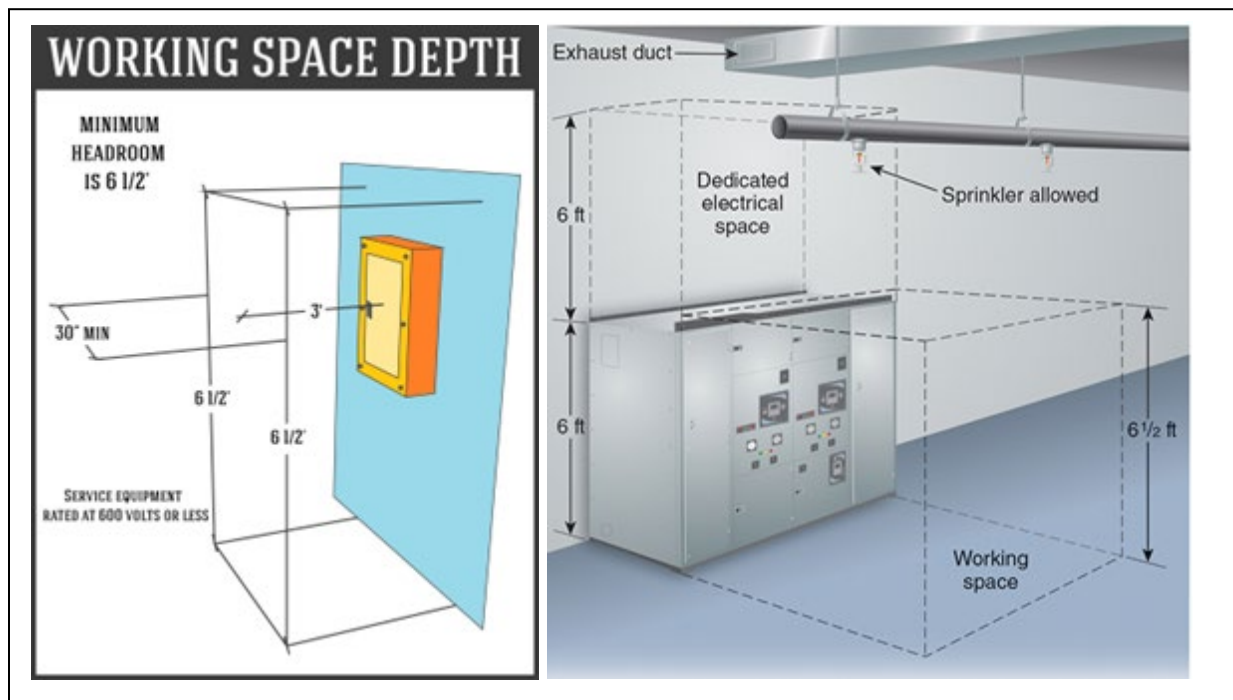

“Typical Working Space in Front of Panelboard”

- Panelboard on a wall.
- Rectangular zone in front of panel with dimensions labeled: depth, width, height.
- Show door swing clear of working space.

6.4 Guarding of Live Parts

Live parts of electrical equipment operating at higher voltages (typically over 50 V) must be **guarded** against accidental contact by:

- Enclosures or cabinets
- Partitions or screens
- Locating in a room or area accessible only to qualified persons
- Elevation above a certain height

7. Grounding and Bonding – Articles 200, 210, 250 Overview

Grounding and bonding is one of the most misunderstood areas of the NEC.

8. Article 210 – Branch Circuits

Article 210 covers **branch circuits**, including receptacle requirements, ratings, and locations.

8.1 Types of Branch Circuits

Common categories include:

- **15- and 20-ampere branch circuits** for general lighting and receptacles
- **Individual (dedicated) branch circuits** for specific appliances (e.g., HVAC, ranges, dryers)
- **Multewire branch circuits** sharing a neutral

8.2 Receptacle Placement in Dwelling Units

The NEC includes rules for:

- **Spacing of receptacle outlets** along walls in habitable rooms
- Requirements for **small-appliance branch circuits** in kitchens
- Receptacles in **bathrooms, laundry areas, garages, outdoors**, and other locations

8.3 GFCI and AFCI for Branch Circuits

The 2023 NEC continues to refine requirements for:

- **GFCI protection** in dwelling and non-dwelling locations such as bathrooms, garages, outdoors, basements, crawl spaces, laundry areas, and specific receptacles near sinks.
- **AFCI protection** in many habitable rooms to mitigate fire hazards caused by arcing faults.

Diagram Placeholder – Figure 5

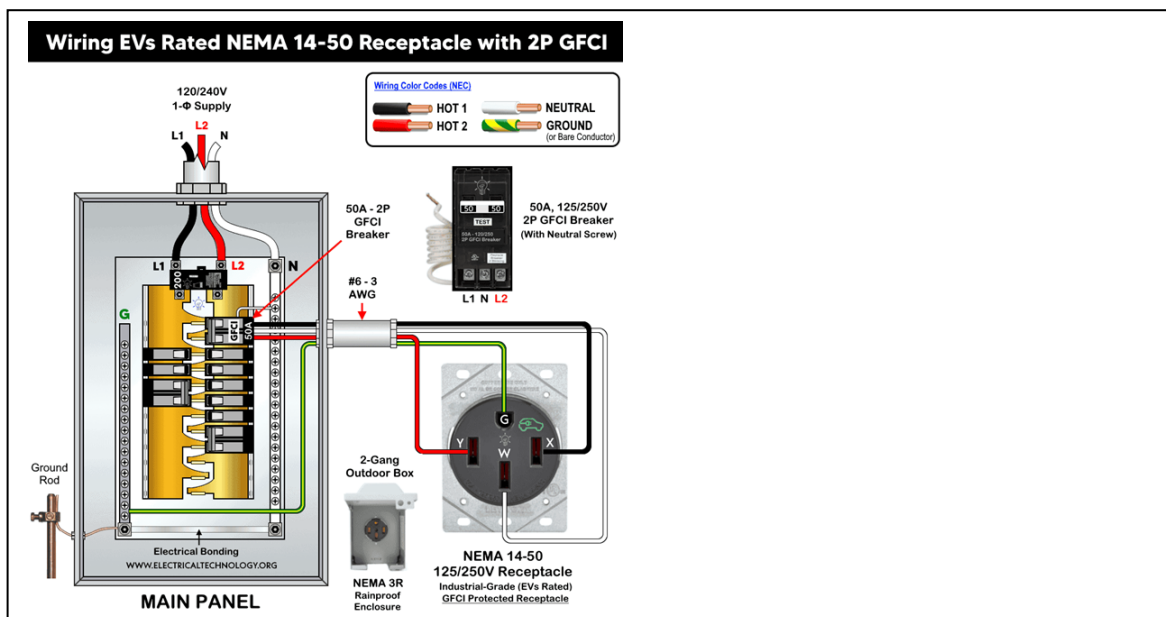

“Sample Dwelling Unit Layout with Branch Circuits and GFCI/AFCI Zones”

- Floor plan with circuits color-coded.
 - Highlight GFCI-protected receptacles in kitchen, bath, garage, exterior.
 - Highlight AFCI-protected bedroom and living areas.
-

9. Articles 215 and 230 – Feeders and Services

9.1 Services (Article 230)

“Service” refers to the conductors and equipment that deliver electric power from the serving utility to the premises wiring.

Key points:

- Service disconnecting means location and grouping.
- Service conductor sizing and protection.
- Service equipment rating and labeling.

9.2 Feeders (Article 215)

Feeders carry power from the service equipment or source to distribution equipment such as subpanels.

- Feeder sizing based on calculated loads.
- Overcurrent protection at the supply end.
- Requirements for grounding and bonding of feeder-supplied equipment.

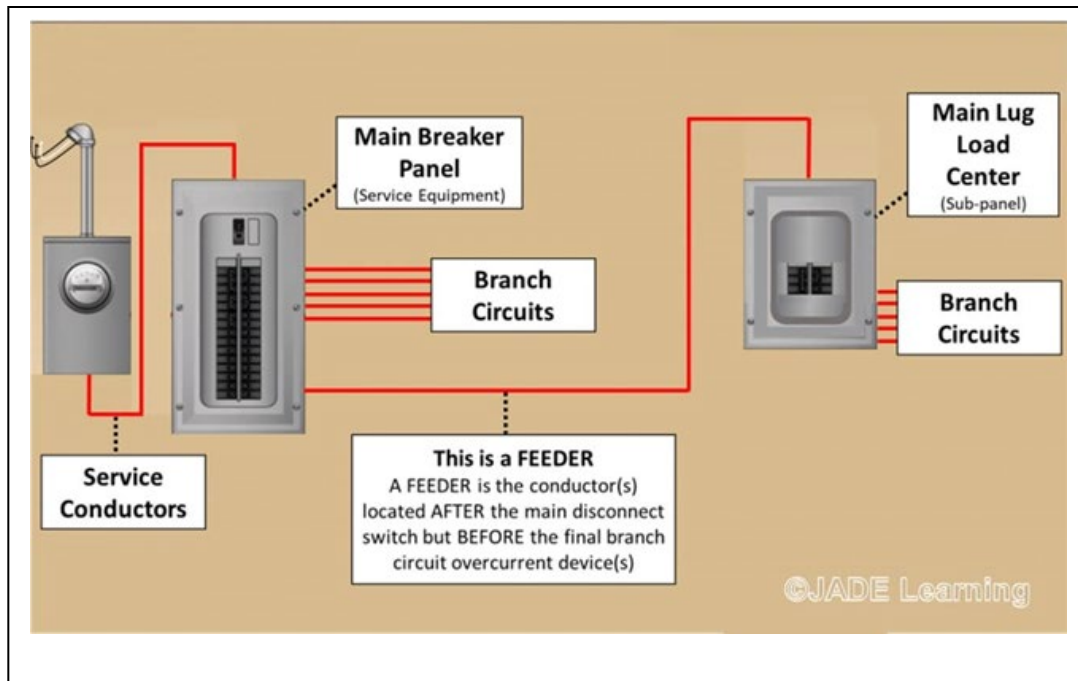

Figure 6 “Service and Feeder Arrangement in a Small Commercial Building”

- Utility transformer → service conductors → main service disconnect → main distribution panel → feeder to subpanel → branch circuits.

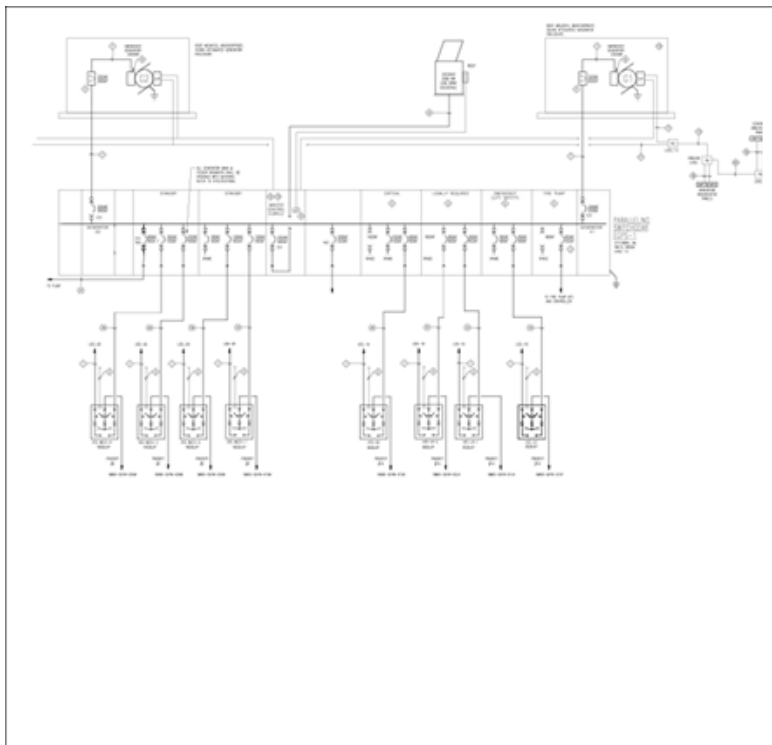















Figure 7 “OCPD, Conductors, and Load Relationship”

- Panelboard breaker feeding conductors sized per ampacity tables, feeding a load.
- Annotate breaker rating, conductor size, ampacity, and load.

Up to 100 ft/ over 100 ft, use next larger size
Safe maximum 80% rated value

600V NM-B	14ga			15 Amp max 12A
600V	12ga			20 Amp max 16A
600V	12-3			20 Amp max 16A
600V	10ga			30 Amp max 24A
600V	10-3			30 Amp max 24A
600V	8ga			40 Amp max 32A
600V	6ga			60 Amp max 48A

© Gene Haynes

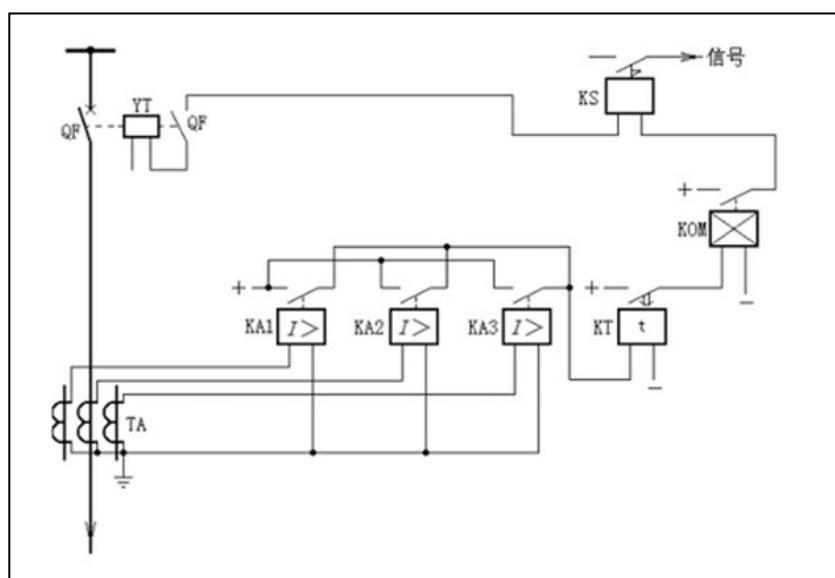

10. Article 240 – Overcurrent Protection

Article 240 regulates **overcurrent protective devices (OCPDs)**, such as fuses and circuit breakers.

10.1 Functions of Overcurrent Protection

- Protect conductors from **overload**.
- Clear **short-circuit** and **ground-fault** conditions safely.

10.2 Conductor and Overcurrent Device Coordination

The NEC requires that:

- Conductor ampacity must be equal to or greater than the OCPD rating (subject to exceptions such as tap rules, motor circuits, etc.).
- Selection must consider **temperature rating** of terminals and conductors, and **derating** for ambient temperature and number of current-carrying conductors.

11. Chapter 3 – Wiring Methods and Materials

Chapter 3 governs how conductors are installed, including raceways, cables, and fittings.

11.1 Article 300 – General Requirements for Wiring Methods

This article covers:

- Protection against physical damage.
- Use of raceways and fittings.
- Penetrations through fire-rated assemblies.
- Support of raceways and cables.

11.2 Article 310 – Conductors for General Wiring

Addresses:

- Types of conductors (THHN, XHHW, etc.)
- Temperature ratings (60°C, 75°C, 90°C)
- Ampacity tables and adjustment factors.

12. Cables and Raceways – Selected Articles

12.1 Nonmetallic-Sheathed Cable (NM-B)

Used extensively in **residential** work where allowed by the building type.

- Restrictions in certain construction types or occupancies.
- Protection where subject to physical damage.

12.2 Metal-Clad Cable (MC)

Common in commercial and certain residential environments.

- Provides a degree of mechanical protection.
- May be used as an equipment grounding conductor in certain configurations.

12.3 Raceways – EMT, RMC, IMC, PVC, etc.

Each raceway type has:

- Permitted locations (indoors, outdoors, wet, hazardous).
- Bending, support, and fill requirements.
- Fittings and termination requirements.

Figure 8

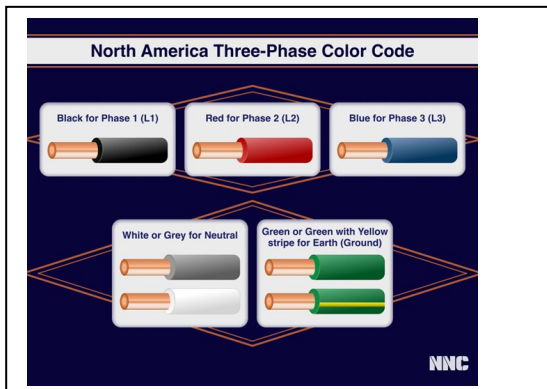

“Typical Raceways and Cables Cross-Section”

- Small sketches: EMT with conductors, MC cable with armor, NM cable.

- Labels for jacket, insulation, conductor, and equipment grounding conductor.

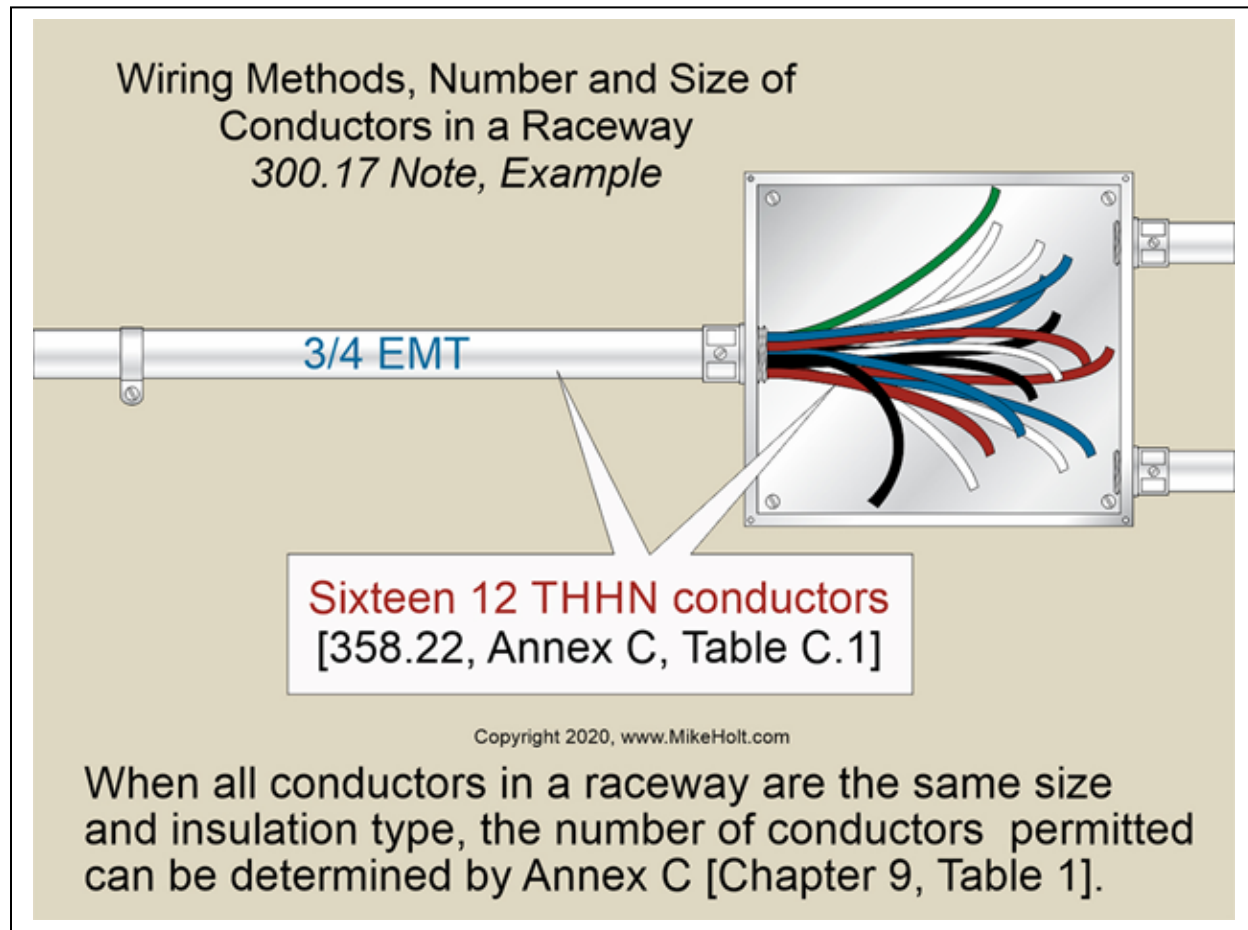

13. Boxes, Cabinets, Panelboards, and Switchboards

13.1 Boxes and Enclosures

Key NEC topics:

- Box fill calculations based on conductor count, device volume allowances, and internal clamps.
- Requirements for grounding metal boxes.
- Covers and support.

13.2 Panelboards and Switchboards

- Rating and listing for the intended environment.
- Busbar and terminations rated for specific temperatures and conductor types.
- Requirements for main overcurrent devices, series rating, and short-circuit ratings.

Figure 9

“Panelboard Interior with Components Labeled”

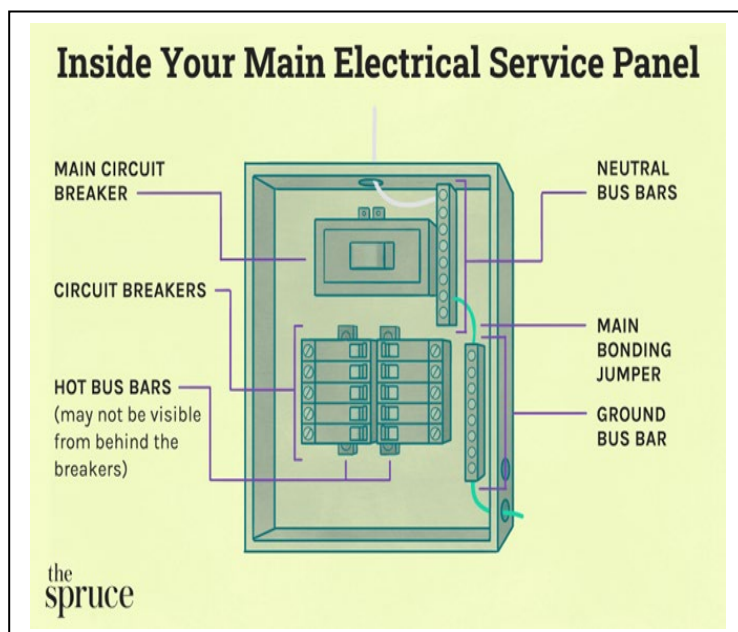
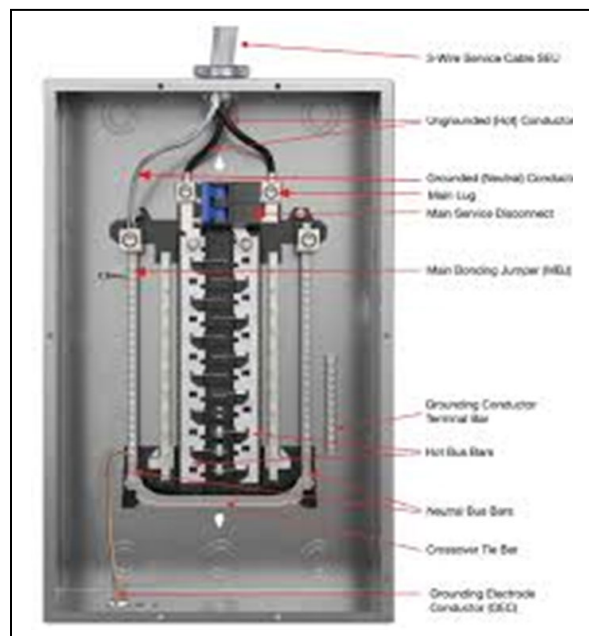

- Main breaker, branch breakers, neutral bus, equipment grounding bus, identification of spaces.

14. Equipment for General Use – Luminaires, Receptacles, Switches

Chapter 4 covers a variety of equipment categories.

14.1 Luminaires (Lighting Fixtures)

NEC provisions apply to:

- Support and mounting methods.
- Connection to branch circuits.
- Requirements for lampholders, recessed luminaires, and location-specific rules (e.g., over bathtubs, in clothes closets).

14.2 Receptacles and Switches

Focus areas:

- **Tamper-resistant receptacles** in certain occupancies (e.g., dwelling units).
- **Weather-resistant receptacles** in outdoor and damp/wet locations.
- Box mounting and device support.

15. GFCI and AFCI Protection – Locations and Requirements (2023 Focus)

Ground-Fault Circuit-Interrupter (GFCI) devices protect people from shock by sensing leakage current to ground and opening the circuit. **Arc-Fault Circuit-Interrupter (AFCI)** devices protect against fires caused by arcing faults.

15.1 2023 NEC GFCI Expansion

The 2023 NEC continues to expand GFCI coverage. Typical areas (conceptual list, always verify exact text):

- Bathrooms
- Garages and accessory buildings
- Outdoors
- Crawl spaces and unfinished basements
- Kitchen countertops
- Within a specified distance of sinks or other water sources
- Laundry areas and similar locations

15.2 AFCI Requirements

AFCIs are required in many dwelling unit **habitable rooms**, such as:

- Family rooms, dining rooms, living rooms
- Bedrooms, closets, hallways
- Other similar aggregate areas

Combination devices (dual-function breakers) are now frequently used to meet both GFCI and AFCI requirements in a single device.

Figure 10
“Panelboard with AFCI and GFCI Breakers Identified”

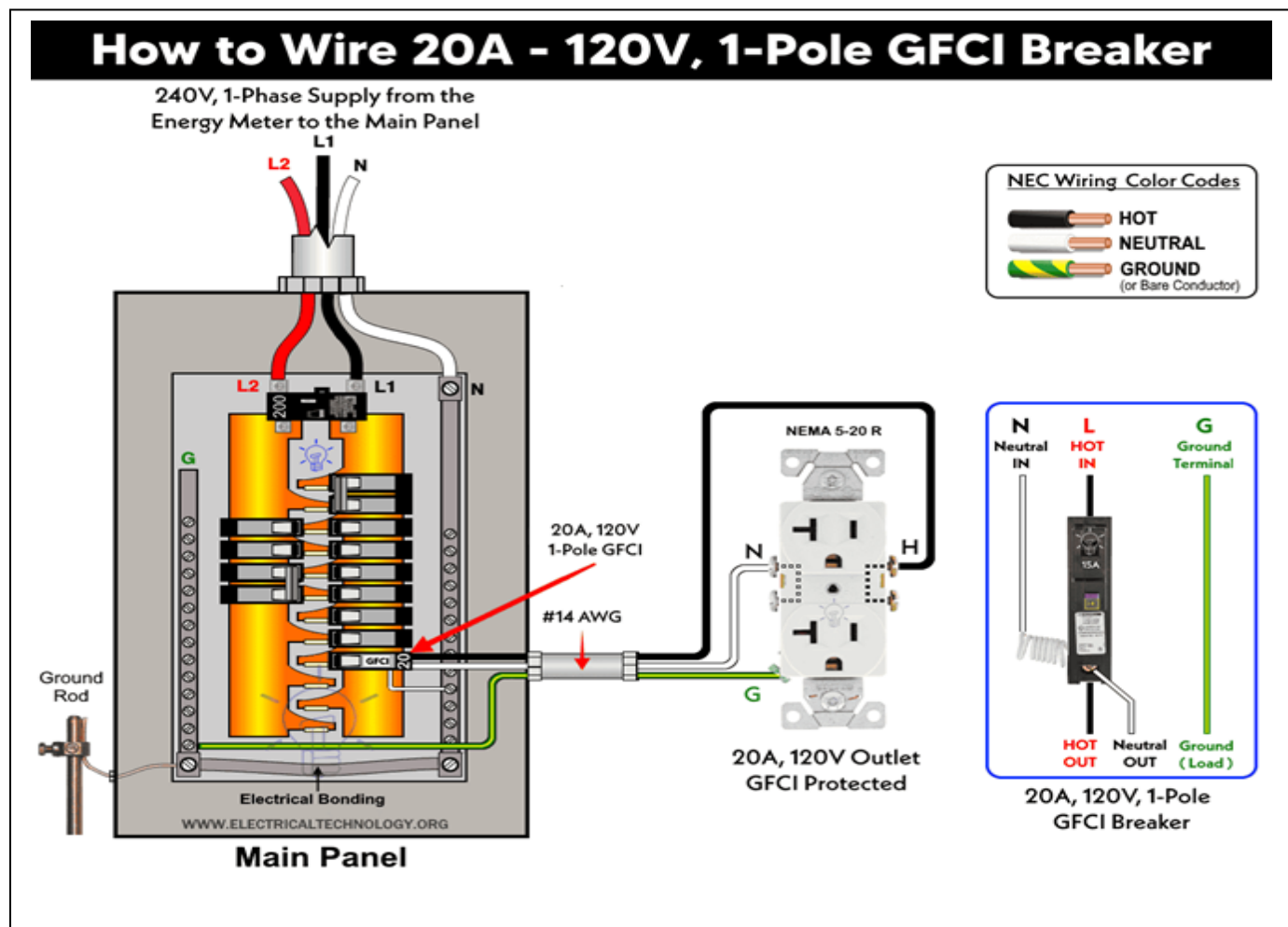

- Show GFCI breaker symbol, AFCI breaker symbol, and dual-function breaker.
- Identify circuits they protect.

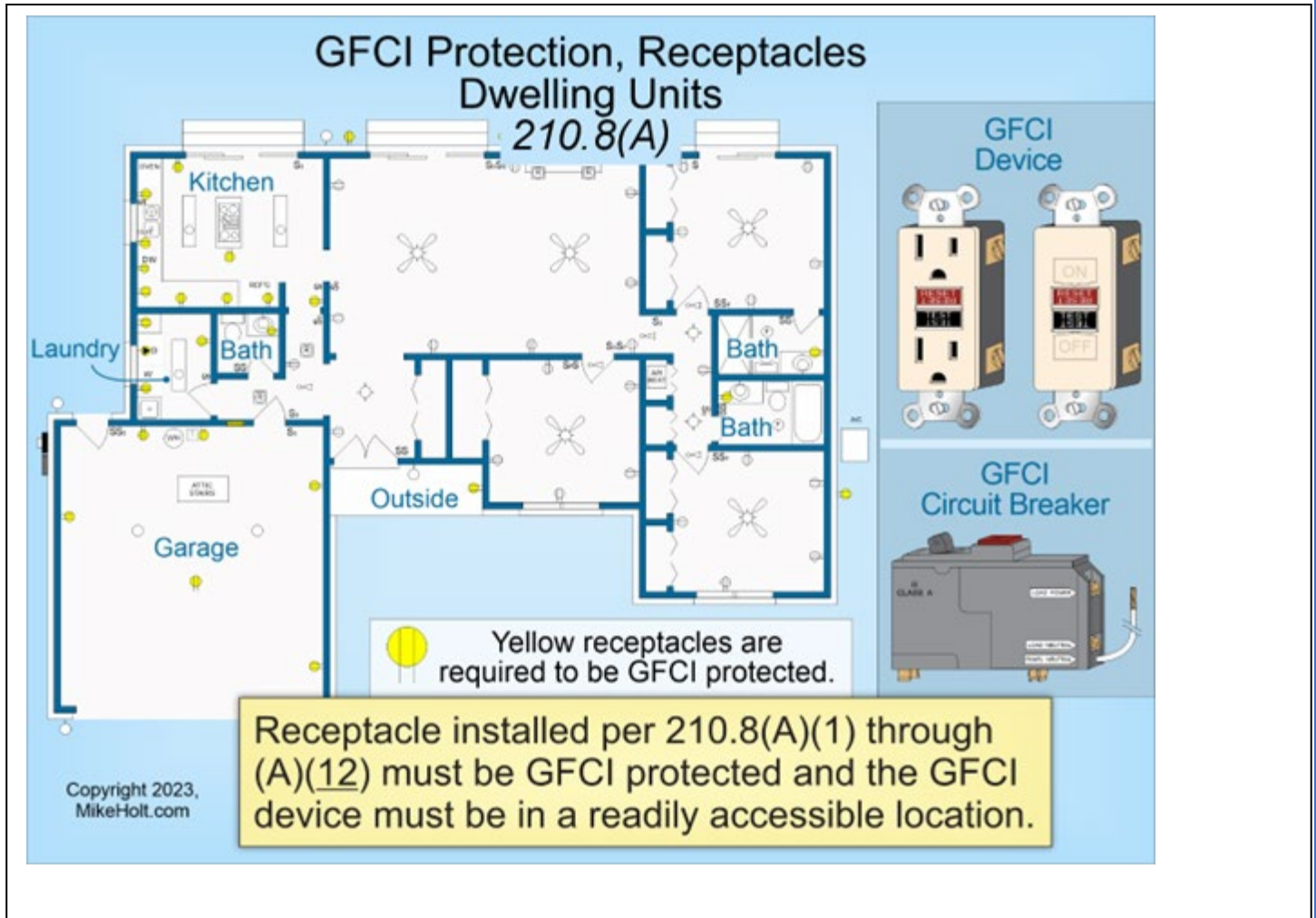

16. Dwelling Units – Selected 2023 NEC Requirements

Residential provisions are heavily tested and widely enforced.

16.1 Service and Load Calculations

NEC Article 220 provides methods for calculating dwelling unit loads, including:

- General lighting and receptacle loads
- Small appliance and laundry circuits
- Fixed appliances and HVAC
- Demand factors for multi-family and large dwellings

16.2 Receptacle Requirements

Common topics:

- Wall spacing rules (no point along the floor line more than a certain distance from a receptacle).
- Required receptacles on specific walls and in specific rooms.
- Additional requirements for island and peninsula countertops in kitchens.

16.3 Bathrooms, Kitchens, and Laundry Areas

- Dedicated circuits and GFCI protection.
- Location of receptacles near basins and countertops.
- Provisions for exhaust fans, lighting, and other equipment.

Figure 11

“Sample Bathroom Plan with Required GFCI Receptacle and Luminaires”

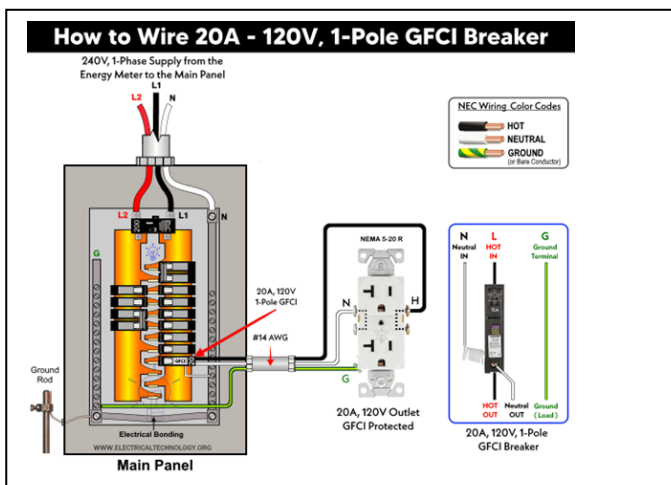

How to Wire a GFCI Receptacle Outlet ?

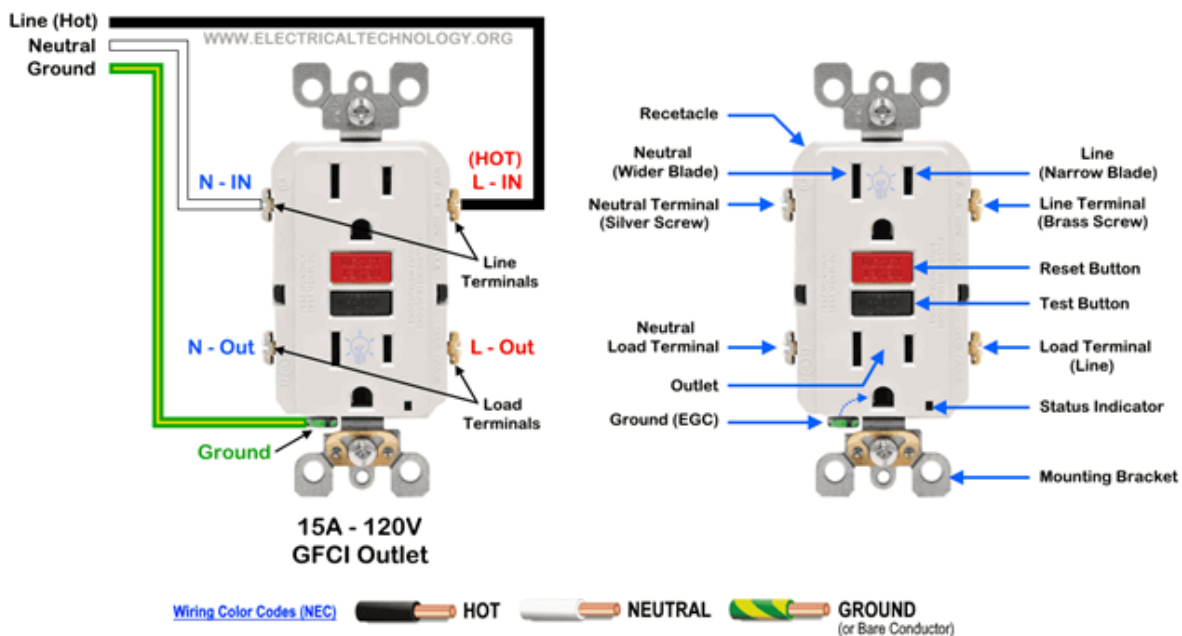

17. Commercial and Industrial Facilities – Key NEC Considerations

While many concepts carry over from dwellings, commercial and industrial projects introduce:

- Larger and more complex service and feeder arrangements.
- Requirements for **selective coordination** among overcurrent devices in emergency and legally required standby systems.
- Additional wiring methods (e.g., cable tray systems, busway, industrial raceways).

17.1 NEC and Selective Coordination

Certain systems (e.g., emergency systems, healthcare essential systems) must be selectively coordinated, meaning:

- Overcurrent devices closest to a fault should clear the fault without tripping upstream devices unnecessarily.
- This may require careful selection of breaker types and time-current curves.

17.2 Motor Circuits and Control

NEC provides:

- Sizing rules for motor branch-circuit short-circuit and ground-fault protection.
- Rules for overload protection.
- Requirements for disconnecting means, controllers, and associated equipment.

18. Special Occupancies – Chapter 5 Highlights

Chapter 5 contains Articles that modify general rules for special occupancies such as:

- Hazardous (classified) locations – explosion-proof and intrinsically safe installations.
- Places of assembly – theaters, churches, restaurants.
- Health care facilities – hospitals, clinics, nursing homes.
- Marinas, RV parks, mobile home parks, etc.

18.1 Hazardous Locations

Different **Classes, Divisions, and Zones** define where flammable gases, vapors, or dusts may be present. The NEC coordinates with other standards for:

- Equipment markings.
- Sealing fittings.
- Wiring methods permitted in each classification.

19. Special Equipment – Chapter 6 (PV, ESS, Generators, EVs)

The growth of **renewable energy** and **energy storage** is a major driver of the 2023 NEC.

19.1 Solar Photovoltaic (PV) Systems

Key NEC topics:

- DC and AC PV source and output circuits.
- Rapid shutdown of PV systems to improve firefighter safety.
- Grounding and bonding of racks and modules.
- Interconnection with utility systems.

19.2 Energy Storage Systems (ESS)

The 2023 NEC includes updated provisions for:

- Battery-based ESS (lithium-ion and others).
- Location requirements (e.g., not in sleeping rooms, considerations for dwelling garages, etc., subject to code text and manufacturer limitations).
- Overcurrent protection, disconnecting means, and ventilation.
- Integration with PV and generator systems.

19.3 Generators and Standby Systems

Topics include:

- Transfer equipment (manual or automatic).
- Separately derived and non-separately derived systems.
- Grounding arrangements and overcurrent protection.

Figure 12
 “Simplified One-Line Diagram: Utility + PV + ESS + Generator”

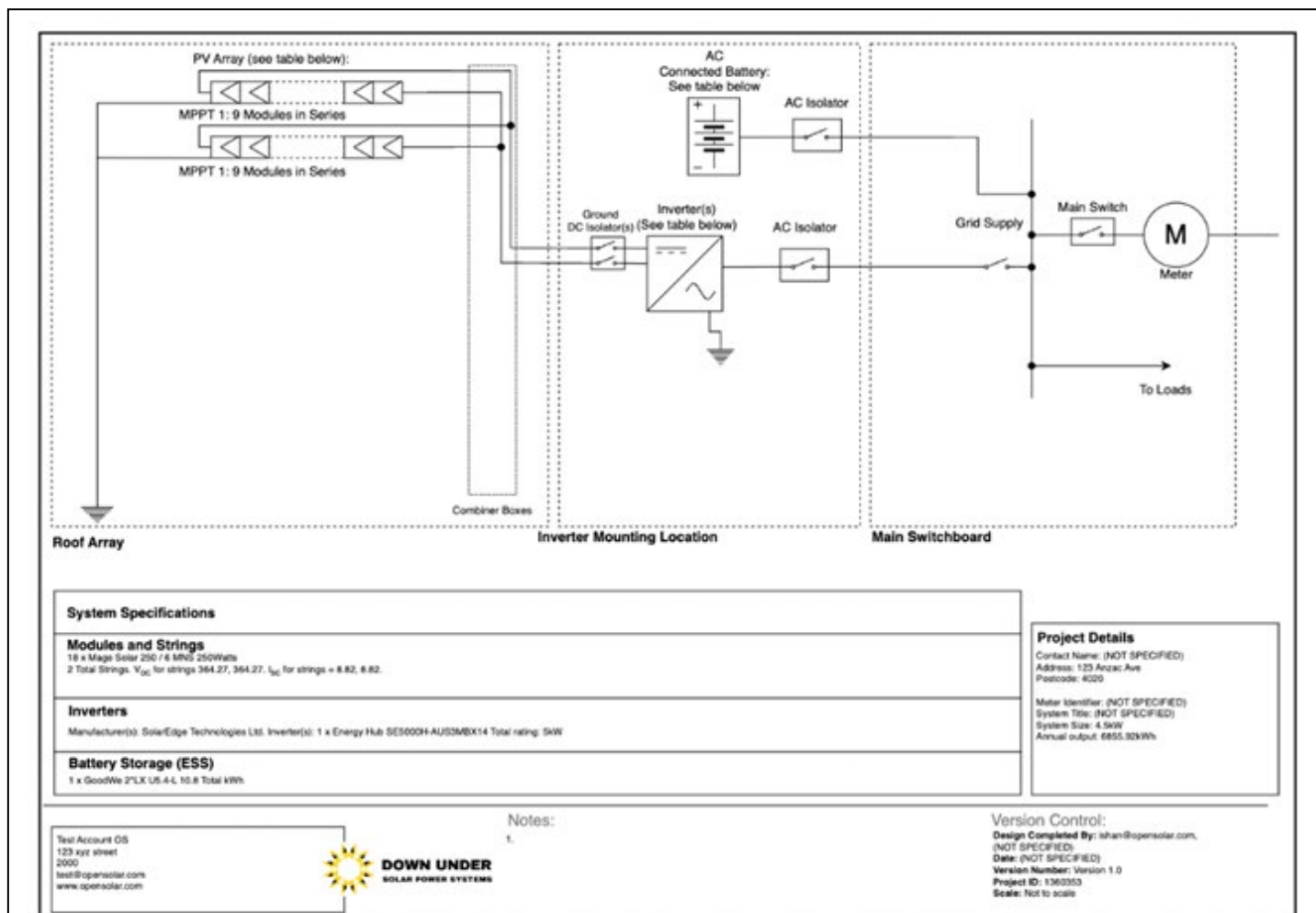

Courtesy of Down Under

20. Ground-Fault and Short-Circuit Calculations (Conceptual Overview)

The NEC requires that equipment have adequate **short-circuit current ratings (SCCR)** and that **overcurrent devices** be properly selected.

Concepts:

- Available fault current at service equipment.
- Coordination with utility fault data.
- Use of impedance, transformer ratings, and conductor lengths to estimate fault levels.
- Ensuring switchgear, panelboards, and disconnects are rated at or above the available fault current.

21. Working Space, Clearances, and Safety Labelling (More Detail)

Beyond initial design, NEC focuses on **safe operation and maintenance**:

- Minimum clearances around equipment.
- Identification of disconnects and circuits (panel directories).
- Warning labels for arc-flash hazards (where required by other standards such as NFPA 70E) and available fault current marking (where mandated by NEC).

Figure 13

“Labeling and Identification on a Typical Panelboard”

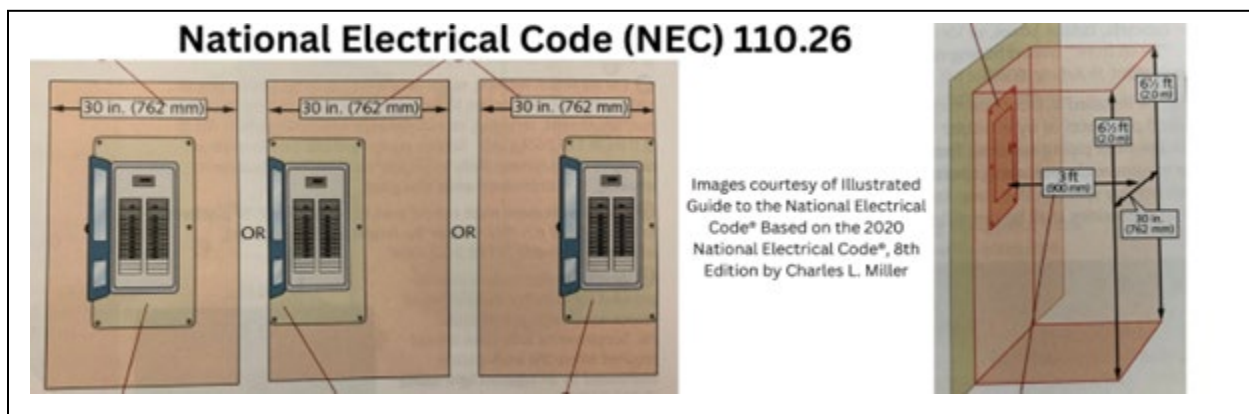



22. Testing, Inspection, and Documentation

NEC assumes that:

- Installations will be inspected by an **AHJ**.
- Certain systems (e.g., emergency systems, fire pump circuits) will be **tested** for proper operation.

Good practice includes:

- Maintaining **as-built drawings**.
- Keeping manufacturer instructions and cut sheets on file.
- Documenting **load calculations, voltage drop analyses, and fault calculations**.

23. Coordination with Building Codes and Other Standards

The NEC does not stand alone. Engineers and electricians must coordinate with:

- **Building codes** (e.g., International Building Code, state codes).
- **Mechanical, plumbing, and fire codes**.
- **NFPA 72** (fire alarm), **NFPA 110** (emergency and standby power), **NFPA 70E** (electrical safety in the workplace).
- **UL standards** and product listings.

24. Common Violations and Field Examples

Typical NEC-related violations seen in the field include:

- Missing or undersized equipment grounding conductors.
 - Overfilled boxes without proper volume.
 - Conductors unprotected from physical damage.
 - Misapplied GFCI/AFCI protection.
 - Improper service and feeder conductor sizing or overcurrent protection.
 - Inadequate working space in front of panels (e.g., storage blocking access).
 - Missing bonding jumpers on metal piping or structural steel.
-

25. Summary, Best Practices, and Study Tips

25.1 Key Takeaways About 2023 NEC

- NEC is a **minimum safety standard**, not a design manual.
- 2023 NEC continues trends toward **expanded GFCI/AFCI coverage**, detailed treatment of **ESS**, **PV**, and **special systems**.
- Proper understanding of **definitions**, **grounding/bonding**, **branch circuits**, **services/feeders**, and **overcurrent protection** is critical for compliance.

25.2 Best Practices

- Always check the **adopted edition** and **local amendments** in your state or municipality.
- Follow **manufacturer instructions** as part of code compliance.
- Maintain clear **documentation** of calculations and design decisions.
- Prioritize **maintainability and safety** in layout and equipment location.