



Lightning Protection



9 PDH

**Professional Development Hours (PDH) or
Continuing Education Hours (CE)
Online PDH or CE course**

Key Terms and Abbreviations

Term	Definition
Air-Termination	Part of the lightning protection system to intercept the lightning flash (strike). For example, an air-terminal providing a protection angle to protected equipment, or horizontal or vertical conductor providing protection via the mesh method
British Standards (BS)	Body responsible for implementation of national British standards, identified by BS prefix
CENELEC	European Committee for Electrotechnical Standardisation (essentially European standard or Norm, identified by EN or NE prefix)
Class (of LPS)	Classification of lightning protection system. Class I, II, III, IV relate to the lightning protection level and define, for example, the different rolling sphere diameters to be used
Earth electrodes	Those parts of the earth termination system in direct contact with the earth, such as ground rods, buried wires, foundation earthing, etc
Earth-termination	Part of the external LPS to dissipate lightning current into the earth
External lightning protection system	Air-termination(s), down-conductor(s) and earth termination(s)
Internal lightning protection system	Equipotential bonding and/or electrical isolation of the external LPS from internal conductive elements
IEC	International Electrotechnical Commission, responsible for formation of International Standards
Lightning protection level (LPL)	Number assigned to represent maximum and minimum lightning parameters that should not be exceeded by natural lightning
Lightning protection system (LPS)	Complete system for lightning protection of structure. Includes internal and external lightning protection measures
Lightning protection zone (LPZ)	Zone where lightning electromagnetic environment is defined
Mesh method (MM)	Method to determine position of air-termination system
Protection angle method (PAM)	Method to determine position of air-termination system
Rolling sphere method (RSM)	Method to determine position of air-termination system
Separation distance	Distance between two conductive parts where no dangerous sparking (flashover) can occur
Services	Circuits and pipes, etc, entering into structure from external environment. Typically phone, power, TV, gas, water, sewerage systems, etc
Surge protective device (SPD)	Device for protecting electrical/electronic equipment from transient voltage damage

Table of Contents

1. IEC AND EN STANDARDS	6
1.1 IEC 62305 series	6
1.2 EN 50164 series.....	6
1.3 Normative and informative	8
1.4 IEC terminology	8
2. THEORY OF THE LIGHTNING FLASH	9
2.1 The thundercloud	10
2.2 Mechanics of the lightning strike	10
2.3 Lightning parameters.....	11
2.4 Lightning damage and risk management	13
3. INTRODUCTION TO PROTECTION METHODS AND RISKS	14
3.1 Risks	15
4. RISK MANAGEMENT	17
4.1 Overview of risk analysis	17
5. LIGHTNING PROTECTION ZONES	22
6. DESIGN PROCESS	23
7. MATERIAL REQUIREMENTS	24
7.1 Copper versus aluminum	24
7.2 Use of dissimilar metals.....	25
7.3 PVC covered and concealed conductors.....	27
7.4 Tape, versus solid round, versus stranded.....	27
8. NATURAL COMPONENTS	28
8.1 Metallic facades, profiles, rails, etc.....	28
8.2 Use of steelwork.....	28
8.3 Use of rebar in reinforced concrete	28
9. DESIGN METHODS	33
9.1 Rolling sphere.....	35
9.2 Mesh method.....	37
9.3 Protection angle method.....	39
10. AIR-TERMINATIONS	43
10.1 Recommendation on positioning.....	44
10.2 Masts and antennas.....	45
10.3 Protection of other items protruding above the roof	45
10.4 Bonding of roof top fixtures.....	48
10.5 Expansion joints and roof penetrations	48
11. DOWN-CONDUCTORS	49
11.1 Down-conductors for isolated and non-isolated LPS.....	50
11.2 Down-conductor routing.....	50
11.3 Fixing of down-conductors	51

Table of Contents *(continued)*

12. BONDING AND SEPARATION DISTANCES	52
12.1 Bonding of services and external conductive parts	52
12.2 Separation distance requirements	53
12.3 Bonding of internal metallic items and other services	54
13. ISOLATED DOWN-CONDUCTOR	55
13.1 Telecommunications applications.....	55
13.2 Other applications.....	56
13.3 Isolated Down-conductor design.....	56
14. EARTHING	57
14.1 Earthing resistance requirements	57
14.2 Type A – vertical and horizontal electrodes	58
14.3 Type B – ring electrode.....	59
14.4 Comparison of Type A and Type B arrangements.....	60
14.5 Foundation earth electrodes.....	60
14.6 Special earthing measures.....	61
14.7 General earthing advice	62
15. INSPECTION AND TESTING	66
16. SPECIAL SITUATIONS	67
16.1 Tall buildings.....	67
17. SURGE PROTECTIVE DEVICES FOR LOW-VOLTAGE POWER DISTRIBUTION SYSTEMS	68
17.1 Surge Protection Devices and Transient Voltages.....	68
17.2 General procedure for SPD selection and installation.....	71
17.3 General information and terms.....	72
17.4 SPD requirements for facilities with lightning protection system.....	73
17.5 SPD requirements for facilities without lightning protection system	77
17.6 Secondary SPD requirements.....	77
17.7 Selection and connection configuration for common power distribution system types	79
17.8 Other installation requirements.....	83
17.9 High risk situations	86
18. SURGE PROTECTIVE DEVICES FOR TELECOMMUNICATIONS AND SIGNALLING SERVICES	87
19. OTHER SURGE PROTECTIVE DEVICE APPLICATIONS	88
20. BRITISH STANDARD BS 6651 AND EN/IEC STANDARDS	89
20.1 BS 6651-1991 compared to BS EN 62305.....	89
20.2 BS EN 62305-2 compared to IEC/EN 62305-2.....	90
21. IEC DESIGN STANDARD AND EN COMPONENT STANDARD CONFLICTS	91

1. IEC and EN Standards

The specification of a lightning protection system should require that the design complies with the IEC 62305 series of design standards and that materials comply with the EN 50164 series of component standards.

The International Electrotechnical Commission (IEC) is a body responsible for implementing international standards. Its technical committees are comprised of representatives from various member national standards, where each country is entitled to one vote during the process of creation and issuing the standard. The standards generally have an IEC prefix to their number (CEI for French versions). IEC standards are produced in English and French languages. For most countries the adoption of these standards is voluntary, and often selected content of the standard is absorbed and introduced as improvements to that country's own standard.

Also, within Europe, there exists the European Committee for Electrotechnical Standardisation (CENELEC). The member countries currently include Austria, Belgium, Cyprus, the Czech Republic, Denmark, Estonia, Finland, France, Greece, Hungary, Iceland, Ireland, Italy, Latvia, Lithuania, Luxembourg, Malta, the Netherlands, Norway, Poland, Romania, Slovakia, Slovenia, Spain, Sweden, Switzerland and the United Kingdom. IEC and CENELEC generally work in parallel, and CENELEC members vote to adopt new IEC standards as CENELEC standards. The committees of CENELEC may choose to make some alterations to the IEC version. Additionally, CENELEC produce their own standards to which IEC have no counterpart. CENELEC documents are produced in English, French and German and an approved CENELEC standard will have an EN prefix (or NE in the French language versions).

The important fact with CENELEC standards is that by rule the member countries are bound to adopt all CENELEC standards as national standards. In the process of adopting these standards, minimum changes are permitted. In-country clauses (exceptions or changes) can only be made under very strict circumstances. When such standards are adopted at the national level, any conflicting national standard must be withdrawn (an overlap period is permitted).

For the EN IEC 62305 series of lightning protection standards, each member country has introduced these at a national level by November 2006 and has withdrawn any conflicting standards by February 2009.

At each level (International, European, National) a different naming prefix convention is used For example:

- IEC 62305-1 (IEC version)
- EN 62305-1 (CENELEC adopted copy of the above)
- EN 62305-1 (British National Standard adoption of the above)

This document focuses upon the IEC/EN standards and, for a specific design, the applicable national standards should be referred to in order to ascertain if differences exist.

Reference in this document is given to standards being either design or component standards. Design standards are those used by the lightning protection designer or installer to determine the type and placement of the lightning protection system. Component standards are those used by the manufacturer of the lightning protection hardware (components) to ensure the hardware is of adequate specification and quality.

1.1. IEC 62305 SERIES

The IEC 62305 series of standards are primarily design standards, giving the user a tool kit of rules and options to provide lightning protection for a structure. The standards cover structure protection and equipment protection with regard to the effects of direct and indirect lightning flashes.

While the IEC 62305 series of standards introduces many new aspects, it is predominantly a European harmonization of the various supporting country lightning protection standards.

“IEC 62305 Protection Against Lightning” is comprised of 4 parts (documents):

- IEC 62305-1 Part 1: General Principles
- IEC 62305-2 Part 2: Risk Management
- IEC 62305-3 Part 3: Physical Damage to Structure and Life Hazard
- IEC 62305-4 Part 4: Electrical and Electronic Systems within Structures
- IEC 62305-5 Part 5: Services (This part was not introduced)

IEC 62305 series of standards expands, updates and replaces the earlier IEC 1024-1-1 (1993) & IEC 1024-1-2 (1998), IEC 61622 (1995 & 1996), IEC 61312-1 (1995), IEC 61312-2 (1998), IEC 61312-3 (2000) & IEC 61312-4 (1998).

Since the IEC 62305 series was parallel approved as a CENELEC standard, the EN version is identical to the IEC version. As a CENELEC standard this means that the EN 62305 standards have replaced the various country source standards, such as BS 6651, NFC 17-100 and DIN VDE 0185.

1.2. EN 50164 SERIES

Within Europe, the CENELEC has released the EN 50164 series of standards. The EN 50164 series are component standards to which the manufacturers and suppliers of lightning protection components should test their products to verify design and quality. The EN 50164 series currently comprises of:

- EN 50164-1 Lightning protection components (LPC) - Part 1: Requirements for connection components

1. IEC and EN Standards (continued)

- EN 50164-2 Lightning protection components (LPC) - Part 2: Requirements for conductors and earth electrodes
- EN 50164-3 Lightning protection components (LPC) - Part 3: Requirements for isolating spark gaps
- EN 50164-4: Lightning Protection Components (LPC) - Part 4: Requirements for conductor fasteners
- EN 50164-5: Lightning Protection Components (LPC) - Part 5: Requirements for earth electrode inspection housings and earth electrode seals
- EN 50164-6: Lightning Protection Components (LPC) - Part 6: Requirements for lightning strike counters
- EN 50164-7: Lightning Protection Components (LPC) - Part 7: Requirements for earthing enhancing compounds

This series of standards is currently being published at IEC level under the name IEC 62561 series.

The EN 50164 series of standards are generally component standards to which the supplier of the equipment should have tested their products. nVent has completed an extensive regime of testing to these standards, and details are available upon request.

EN 50164-1 scope covers connection components such as connectors, bonding and bridging components and expansion pieces as well as test joints. The intent of this standard is that any mechanical connection between the tip of the air-terminal and the bottom of the earth electrode should be tested. This covers the more obvious down-conductor connectors (cross-over connectors, tape clamps, etc) and down-conductor test links, to the less obvious air-terminal (rod) to air-terminal base connection and down-conductor to earth electrode connection.

EN 50164-1 testing classifies the products according to their capability to withstand lightning current by an electrical test:

- Class H - Heavy Duty (tested with 100 kA 10/350 μ s), or
- Class N - Normal duty (tested with 50 kA 10/350 μ s)

And according to its installation location by environmental test:

- Above ground (salt mist & sulphurous atmosphere tests), and
- Buried in ground (chloride and sulphate solution test)

EN 50164-2 scope covers metallic conductors, down-conductors (other than “natural” conductors such as building reinforcing steel) and earth electrodes. It should be noted that the metallic conductor requirement also covers the air-terminals (rods). The tests include measurements to confirm compliance with minimum size requirements, resistivity and environmental testing. Earth electrodes are subjected to tests including bend tests, adhesion tests, and environmental tests. Coupled earth electrodes and the coupling device are also subjected to hammer compression (impact testing) and the requirements of IEC 62305-1.

EN 50164-3 scope covers isolating spark gaps used in lightning protection systems, such as those used to bond metal work to a lightning protection system where direct connection is not permissible for functional reasons.

EN 50164-4 scope covers tests procedures and requirements for metallic and non-metallic fasteners used on most (but not all) wall and roof materials to secure air termination systems and downconductors. Fasteners used in explosive atmospheres should be subjected to additional requirements not defined in this standard.

Standard	Title	Type
IEC 62305-1 (EN 62305-1)	Protection against lightning - Part 1: General principles	Design Standard
IEC 62305-2 (EN 62305-2)	Protection against lightning - Part 2: Risk Management	Design Standard
IEC 62305-3 (EN 62305-3)	Protection against lightning - Part 3: Physical Damage to Structure and Life Hazard	Design Standard
IEC 62305-4 (EN 62305-4)	Protection against lightning - Part 4: Electrical and Electronic Systems within Structures	Design Standard
EN 50164-1	Lightning protection components (LPC) - Part 1: Requirements for connection components	Component Standard
EN 50164-2	Lightning protection components (LPC) - Part 2: Requirements for conductors and earth electrodes	Component Standard
EN 50164-3	Lightning protection components (LPC) - Part 3: Requirements for isolating spark gaps	Component Standard
EN 50164-4	Lightning protection components (LPC) - Part 4: Requirements for conductor fasteners	Component Standard
EN 50164-5	Lightning protection components (LPC) - Part 5: Requirements for earth electrode inspection housings and earth electrode seals	Component Standard
EN 50164-6	Lightning protection components (LPC) - Part 6: Requirements for lightning strike counters	Component Standard
EN 50164-7	Lightning protection components (LPC) - Part 7: Requirements for earthing enhancing compounds	Component Standard

Table I. *Main IEC and EN standards relating to design and testing of lightning protection systems/components.*

1. IEC and EN Standards (continued)

EN 50164-5 scope covers requirements and tests for earth pits and earth seals made of steel, plastic, concrete among others. Load-bearing capacity tests and seal quality tests are the key tests covered in the standard.

EN 50164-6 scope covers test procedures and requirements for lightning strikes counters used in lightning protection systems but also in surge protection systems. Mechanical, electrical and corrosion tests are described in this standard and electromagnetic compatibility is also addressed.

EN 50164-7 scope covers the requirements and tests for earth enhancing compounds used to increase the contact surface area of earth electrodes. Refill materials are not part of this standard. Among the tests included in the standard are conductivity tests, chemical tests (pH, solubility in acid environments), and composition tests (sulfur).

At this time, while EN 50164-1, EN 50164-2 and EN 50164-3 are CENELEC standards and thus compliance is required, the IEC 62305 series do not fully refer to these standards. That is to say, while you must use EN 50164-1/2/3 approved components, IEC/EN 62305 series, for example, does not actually specify for which circumstances EN 50164-1 Class H or Class N materials are required. It is strongly recommended that Class H be used in all applications, but with Class N devices being permitted for bonding to items not subject to the full lightning current.

It should also be known that there are some small differences between the material requirements of the EN component standards and the material specifications in the IEC design standards, such as minimum conductor sizes and tolerance. Therefore it is possible for example, to have a conductor that meets the requirements of design standard IEC 62305-3, but not the component standard EN 50164-2. Refer to Section 21 for further information.

Manufacturers and suppliers of lightning protection components should be able to provide test reports for each of their products stating compliance to these standards. Importantly, the classification (class and environment) should be stated together with the scope of testing. Note that the approval is only valid for the combinations of conductor sizes and configurations tested. For example, the approval is unlikely to be valid if the connector is used with non-standard conductor sizes.

1.3. NORMATIVE AND INFORMATIVE

It should be understood that the main body of standards are normative. That is, the requirements given are mandatory (unless otherwise indicated in the text). At the rear of the standard, annexes provide additional support information and examples.

The annexes may be headed as normative or informative. A normative annex means any requirements are mandatory, while an informative annex is for information purposes and any contained requirements are recommendations (i.e. non-mandatory).

To summarize earlier information, with the exception of CENELEC member countries, the requirements of IEC 62305 series, EN 50164 series, or a national version of one of these documents is only mandatory if the country has specifically adopted the standard. Any local national standard will take precedence. For CENELEC member countries the standards are mandatory with compliance being required to the national implementation if existing, or otherwise the EN version.

1.4. IEC TERMINOLOGY

Where practical, this document uses IEC defined terms and definitions. For example the term “earthing” is used in preference to “grounding”. Within the lightning protection industry there is often indiscriminate use of incorrect terms associated with the lightning event. The following explains the preferred terms.

Term	Definition
Lightning stroke	Single electrical discharge in a lightning flash to earth. The lightning flash may have multiple strokes
Lightning flash	Electrical discharge of atmospheric origin between cloud and earth consisting of one or more strokes
Multiple stroke	A lightning flash where more than one stroke (electrical discharge) occurs
Point of stroke	Point where lightning flash strikes earth/object
Lightning current	Current flowing at point of strike

Table 2. Main IEC terms associated with the lightning event.

Lightning is a common event. At any one time, there are some 1700 electrical storms active throughout the world, producing in excess of 100 flashes per second. This equates to an aggregate of some 7 to 8 million flashes per day. Of these, approximately 90% are cloud-to-cloud flashes and the remaining are predominately cloud-to-ground flashes. Tropical regions of the world have particularly high incidences of lightning as depicted by isokeraunic thunder day maps.

Common Terminology	IEC Terminology
Lightning strike	Lightning flash
Discharge current	Lightning current

Table 3. Common non-IEC terminology.

2. Theory of the Lightning Flash

With increasingly complex and sophisticated buildings and equipment, a single lightning stroke can result in physical damage and catastrophic failure. It can initiate fire, cause major failures to electrical, telephone and computer services and simultaneously cause substantial loss of revenue through down-time.

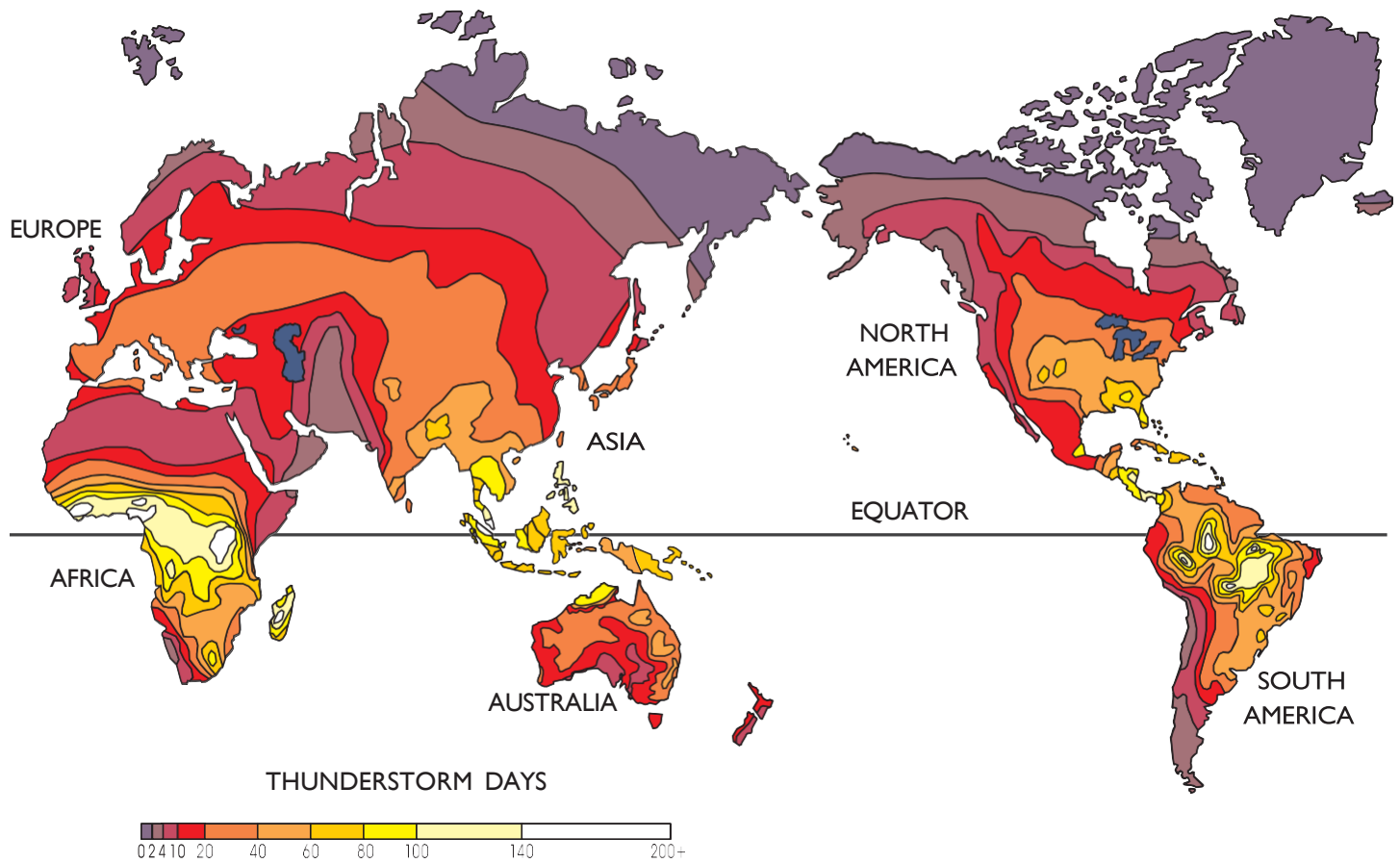


Figure 1. World thunder day map; note the high lightning density areas are regionalized around the equator.

2. Theory of the Lightning Flash (continued)

2.1. THE THUNDERCLOUD

Lightning is a natural phenomenon which develops when the upper atmosphere becomes unstable due to the convergence of a warm, solar heated, vertical air column on the cooler upper air mass. These rising air currents carry water vapor which, on meeting the cooler air, usually condense, giving rise to convective storm activity. Pressure and temperature are such that the vertical air movement becomes self-sustaining, forming the basis of a cumulonimbus cloud formation with its center core capable of rising to more than 15,000 meters.

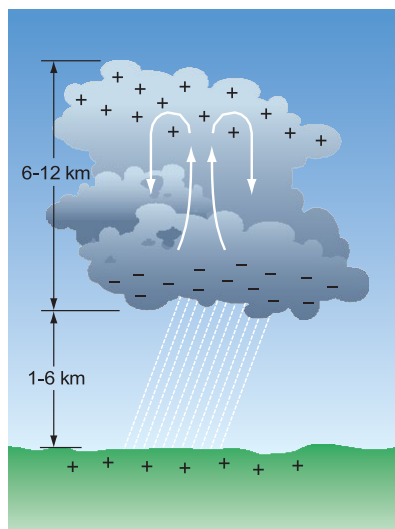


Figure 2. Typical charge distribution in cumulonimbus cloud.

To be capable of generating lightning, the cloud needs to be 3 to 4 km deep. The taller the cloud, the more frequent the lightning. The center column of the cumulonimbus can have updrafts exceeding 120 km/hr, creating intense turbulence with violent wind shears and consequential danger to aircraft. This same updraft gives rise to an electric charge separation which ultimately leads to the lightning flash. **Figure 2** shows a typical charge distribution within a fully developed thunder cloud.

Lightning can also be produced by frontal storms where a front of cold air moves towards a mass of moist warm air. The warm air is lifted, thus generating cumulonimbus clouds and lightning in a similar mechanism to that described earlier. One major differentiation of this type of event is that the cold front can continue its movement and result in cumulonimbus clouds spread over several kilometers width. The surface of the earth is negatively charged and the lower atmosphere takes on an opposing positive space charge. As rain droplets carry charge away from the cloud to the earth, the storm cloud takes on the characteristics of a dipole with the bottom of the cloud negatively charged and the top of the cloud positively charged. It is known from waterfall studies that fine precipitation acquires a positive electrical charge. Larger particles acquire a negative charge. The updraft of the cumulonimbus separates these charges by

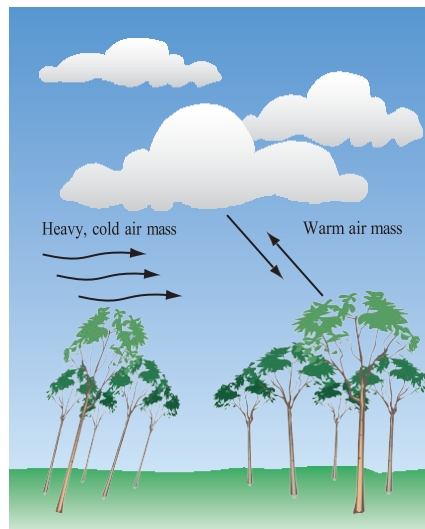


Figure 3. Cumulonimbus clouds generated by frontal storms.

carrying the finer or positive charges to high altitudes. The heavier negative charges remain at the base of the cloud giving rise to the observance that approximately 90% of all cloud-to-ground flashes occur between a negatively charged cloud base and positively charged earth (i.e. negative lightning).

Approximately 90% of all lightning flashes are cloud-to-cloud with the other 10% being cloud-to-ground flashes.

Ground-to-cloud flashes are extremely rare and generally only occur from high mountain tops or tall man-made structures – they are typically positive strokes (positive lightning).

2.2. MECHANICS OF THE LIGHTNING STRIKE

The separation of electrical charge within a cloud allows electric potentials to increase to a point where a neutralizing discharge must occur. For lightning protection, we are mainly concerned about the cloud-to-ground discharge. This is a two-staged process, with one process being initiated from the cloud, while the second is initiated from the ground or structure.

Ionization occurs at the bottom of the cloud to form corona discharges. A leader initiates and begins to propagate towards the ground. The presence of wind shear tends to blow away the ionized air, halting the progression momentarily until sufficient ionization develops to cause breakdown and allow the discharge to progress in the next discrete step. This stepped leader progresses rapidly towards the ground and may branch into many "fingers" in an attempt to reach ground.

As the leader approaches the ground, the electric field rapidly increases, accelerating local ground ionization. At this point, the potential difference between the leader and the earth may be as great as 100 million volts, resulting in final breakdown of the air. The ground discharge begins to move up (upward leader) towards the downward leader, intercepting at some tens to hundreds of meters above ground level.

2. Theory of the Lightning Flash (continued)

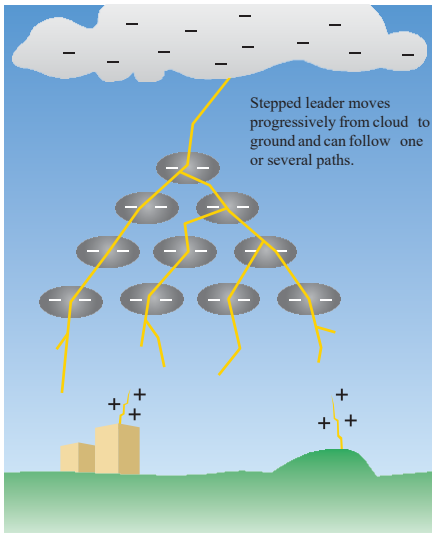


Figure 4. The stepped leader progressing towards earth.

Once the ionized channel has been completed by the junction of the upward and downward leaders, a low impedance path between the cloud and ground exists and the main stroke commences. This is characterized by a rapidly increasing electric current whose rate of rise is typically $10 \text{ kA}/\mu\text{s}$. Peak currents averaging around 30 kA are typical, with minimum currents being a few kA . Maximum lightning currents exceeding 200 kA have been recorded.

It is also possible to have consecutive strokes down the same channel. This occurs when the initial discharge neutralizes the localized charge cell in the cloud. Nearby cloud cells then flash across to the ionized channel and use it to discharge to ground. In this manner, up to 16 strokes have been observed using the one channel. These multiple strokes within the one lightning flash are sometimes referred to as re-strikes.

The average energy released in a lightning flash is 55 kWh , a significant amount of energy by modern generation standards. The danger of the lightning current lies in the fact that all the energy is expended in only 100 to 300 microseconds and that the peak lightning current is reached in only 1 to 2 microseconds.

The difference between positive and negative lightning is that the leader in the case of positive lightning is generally not stepped and there are rarely multiple strokes. There is typically only one return stroke, after which a continuous current flows to discharge the cloud.

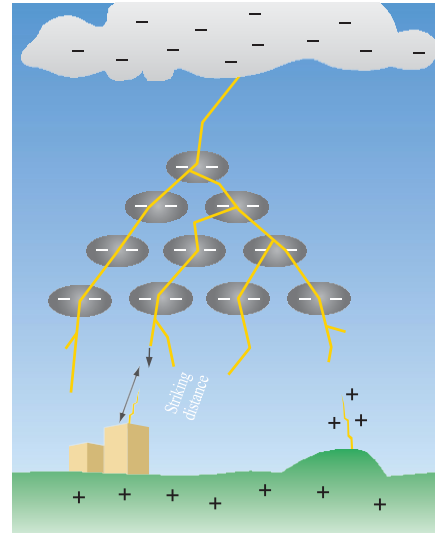


Figure 5. Upward leader completes the ionized channel.

2.3. LIGHTNING PARAMETERS

Lightning is a natural phenomenon where, for the purpose of analysis and design, a statistical approach is taken. Data from International Council of Large Electrical Systems (CIGRE) indicates that:

- 5% of first, negative lightning strokes exceed 90 kA (average is 33 kA)
- 5% of positive lightning strokes exceed 250 kA (average is 34 kA)
- 5% of negative subsequent strokes exceed a rate of current rise of $161 \text{ kA}/\mu\text{s}$

In the IEC 62305 series, four lightning protection levels are introduced and the design rules are based on the LPS being able to protect against maximum values (“sizing efficiency”) and minimum values (“interception efficiency”) of current. LPL I offers the highest protection level (greatest level of protection), with LPL IV offering the lowest level of protection.

Table 4 indicates for these lightning protection levels the maximum current expected and the probability that this may be exceeded. The standard ensures that air-termination, conductor and earth termination size are sufficient to withstand the expected maximum current.

	LPL I	LPL II	LPL III	LPL IV
Maximum peak current (kA 10/350 μs)	200	150	100	100
Probability current is greater (%)	1	2	3	3

Table 4. Maximum current levels (related to sizing efficiency) for lightning protection levels I to IV and probability of exceeding these levels.

2. Theory of the Lightning Flash (continued)

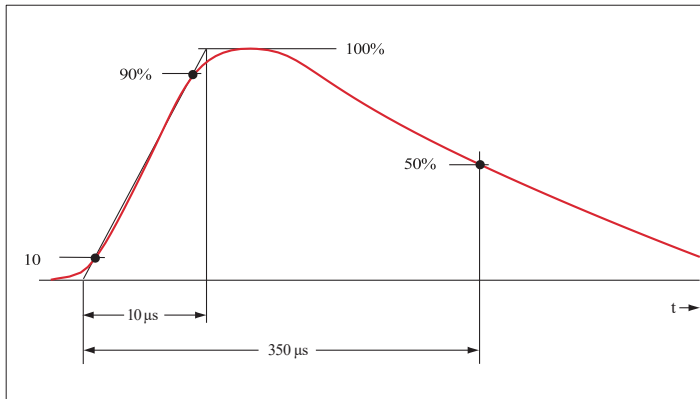


Figure 6. Waveshape.

While the actual waveshape of the lightning current varies from event to event, research shows that a statistical probability can be determined for occurrence of a given waveshape. For the purpose of simplification the maximum values in **Table 4** are specified using a 10/350 μ s waveshape. As shown in **Figure 6**, for a 10/350 μ s event the front time (also known as rise time) is 10 μ s duration and the time to decay to 50% is 350 μ s.

For air-terminal placement, the main consideration is the minimum value of expected current and the ability of the lightning protection system to intercept these smaller flashes. As noted earlier, as the lightning downward leader approaches the ground or structure, the electric field increases to the point that the ground or structure launches an upward leader that may eventually intercept the downward leader. This is termed the “striking distance”. The larger the amount of charge carried by the lightning leader, the greater will be the distance at which this happens. The larger the charge of the leader, the larger the resulting lightning current. It is generally accepted that the striking distance r is given by:

$$r = 10 I^{0.65}$$

Where I is the peak current of the resulting stroke.

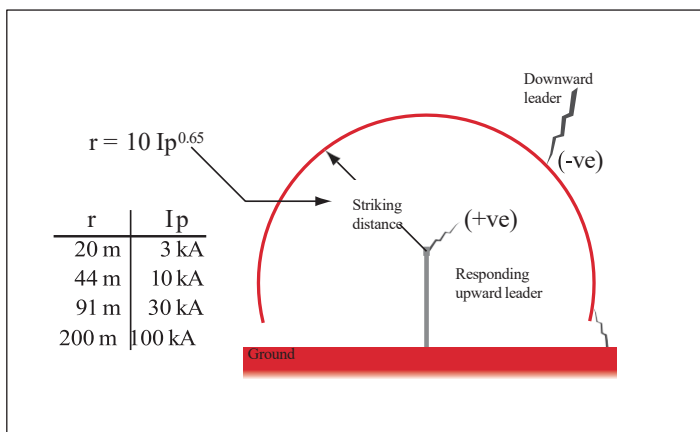


Figure 7. Striking Distance.

This formula shows that it is more difficult for an air-terminal to intercept a smaller lightning flash than a larger flash, as the smaller flash must approach closer to the air-terminal before the upward leader is launched. To protect the structure against smaller lightning flashes, air-terminals must be spaced closer together. For smaller lightning flashes there is a risk that an air-terminal may not be close enough to intercept the down leader, thus a closer structural point releases an upward leader which intercepts the flash (i.e. the building is struck).

For each of the lightning protection levels, a minimum current level to be protected against has been determined (selected).

Table 5 details these current levels, together with probability percentages that lightning may be greater than these levels. For example, LPL I positions terminals such that 99% of all lightning flashes are intercepted (all those of 3 kA or greater). There is only a 1% probability that lightning may be smaller than the 3 kA minimum, and may not be close enough to an air-terminal to be intercepted. It should be noted that flashes of less than 3 kA are rare, and typically would not be expected to cause damage to the structure. Protection greater than LPL I (99%) would require significantly more material, is not covered by the standard and generally is not required for commercial construction.

	LPL I	LPL II	LPL III	LPL IV
Minimum current (kA)	3	5	10	16
Probability current is greater than minimum (%)	99	97	91	84
Rolling sphere radius (m)	20	30	45	60

Table 5. Minimum current levels (related to interception efficiency) for lightning protection levels I to IV.

The lower lightning protection levels (LPL II, III & IV) each increase the air-terminal spacing, reducing their ability to capture smaller lightning flashes, thus reducing overall the percentage of lightning events they can protect against.

Table 5 also details the rolling sphere radius used in the rolling sphere design method. The rolling sphere method is the preferred method for determining positioning of air-terminals (protection angle method and mesh method are described later). The radius of the sphere is equal to the striking distance (using earlier formula) associated with the minimum current level for the chosen lightning protection level. This imaginary sphere is rolled over the structure. The surface contact points traced out by the sphere define possible points that may launch an upward leader to intercept with the downward leader. All these points are deemed to require protection, whilst the untouched points do not. Generally a lightning protection system is designed such that the rolling sphere only touches the lightning protection system and not the structure.

To further explain **Table 5**, a lightning protection system to provide LPL IV, designed using the rolling sphere method, would use air-terminals placed using a rolling sphere radius of 60 m.

2. Theory of the Lightning Flash (continued)

These air-terminals would be positioned such that they would capture all lightning flashes of 16 kA or greater, thus offering protection to at least 84% of the lightning (the term “at least” is used to indicate that the percentage of lightning captured might be greater, since smaller lightning flashes could be captured if they were closer to the air-terminal). To offer a greater lightning protection level (e.g. LPL I, II or III) a smaller rolling sphere radius would be used. This would result in a reduced spacing between air-terminals (more air-terminals), thus positioning the air-terminals to capture smaller lightning flashes, and increasing the total percentage of lightning flashes captured.

2.4. LIGHTNING DAMAGE & RISK MANAGEMENT

No lightning protection system is 100% effective. A system designed in compliance with the standard does not guarantee immunity from damage. Lightning protection is an issue of statistical probabilities and risk management. A system designed in compliance with the standard should statistically reduce the risk to below a pre-determined threshold. The IEC 62305-2 risk management process provides a framework for this analysis.

An effective lightning protection system needs to control a variety of risks. While the current of the lightning flash creates a number of electrical hazards, thermal and mechanical hazards also need to be addressed.

Risk to persons (and animals) include:

- Direct flash
- Step potential
- Touch potential
- Side flash
- Secondary effects:
 - asphyxiation from smoke or injury due to fire
 - structural dangers such as falling masonry from point of strike
 - unsafe conditions such as water ingress from roof penetrations causing electrical or other hazards, failure or malfunction of processes, equipment and safety systems

Risk to structures & internal equipment include:

- Fire and/or explosion triggered by heat of lightning flash, its attachment point or electrical arcing of lightning current within structures
- Fire and/or explosion triggered by ohmic heating of conductors or arcing due to melted conductors
- Punctures of structure roofing due to plasma heat at lightning point of strike
- Failure of internal electrical and electronic systems
- Mechanical damage including dislodged materials at point of strike

3. Introduction to Protection Methods & Risks (continued)

3 INTRODUCTION TO PROTECTION METHODS AND RISKS

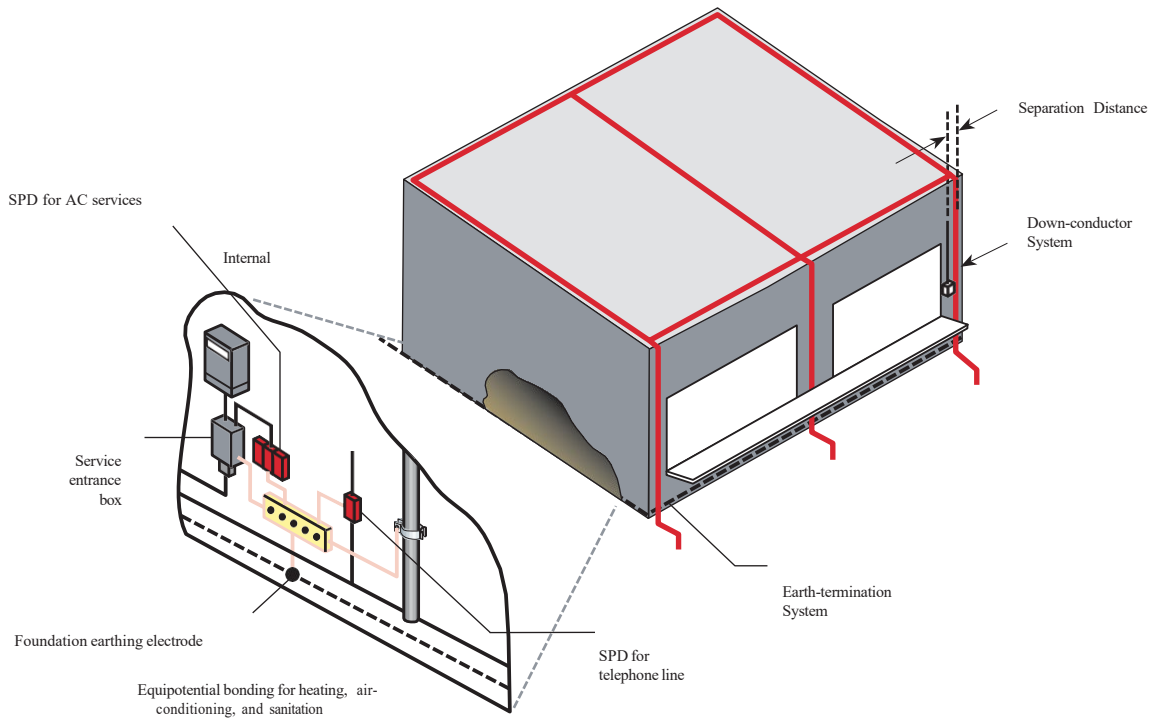
The infancy of the science of lightning protection is best attributed to Benjamin Franklin. The story of his kite flying experiment to prove that lightning was the same type of electricity as that stored in a Leyden jar, is well documented and has become a modern day legend. The first mention of the traditional lightning rod was published by Franklin in 1750 in *Gentleman's Magasine [sic]* and then later in his treatises on the subject published in 1751. In this he recommends the use of lightning rods to "... Secure houses, etc, from Lightning".

In 1876, Franklin's research was taken further by James Clerk Maxwell who suggested that by completely enclosing a building with metal cladding, lightning current would be constrained to the exterior of the building and no current would flow within the building itself. This concept has given rise to a relatively more cost effective approach known as the Faraday Cage (mesh method), in which a matrix of conductors is used to form an equipotential cage around the structure to be protected.

- In achieving this the lightning protection system must:
- Not cause thermal or mechanical damage to the structure
- Not cause sparking which may cause fire or explosion
- Limit step and touch voltages to control the risk of injury to occupants
- Limit damage to internal electrical and electronic systems

The lightning protection system is generally considered in two parts. The external lightning protection system intercepts, conducts and dissipates the lightning flash to earth. The internal lightning protection system prevents dangerous sparking within the structure (using equipotential bonding or separation distance).

- The design of a lightning protection system needs to:
- Intercept lightning flash (i.e. create a preferred point of strike)
- Conduct the lightning current to earth
- Dissipate current into the earth
- Create an equipotential bond to prevent hazardous potential differences between LPS, structure and internal elements/circuits



3. Introduction to Protection Methods & Risks (continued)

Figure 8. *External and internal lightning protection system.*

3. Introduction to Protection Methods & Risks *(continued)*

Lightning protection systems typically follow two approaches:

Non-isolated system - where potentially damaging voltage differentials are limited by bonding the lightning protection system to the structure

Isolated system - where the lightning protection system is isolated from the structure by a specified separation distance. This distance should be sufficient that energy is contained on the LPS and does not spark to the structure. Isolated systems are well suited to structures with combustible materials such as thatched roofs, or telecommunication sites that want to avoid lightning currents being conducted on masts and antenna bodies

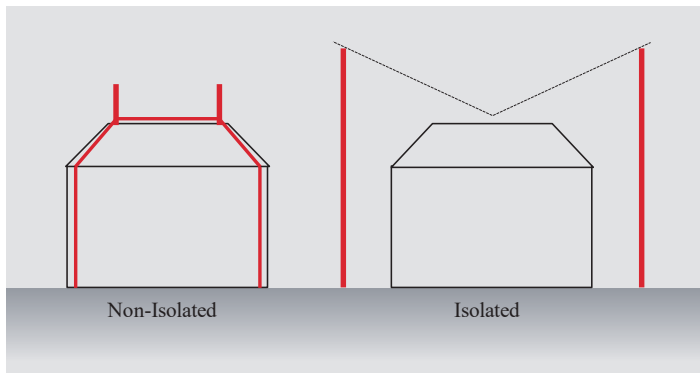


Figure 9. Non-isolated protection concepts.

The standard provides simple geometric forms of design which are comprised of cost, effectiveness and simplicity in design. The design methods are:

- Mesh method
- Rolling sphere method (RSM)
- Protection angle method (PAM)

These methods (described in **Section 9**) are used to determine the optimum location of the air-terminations and the resulting down-conductor and earthing requirements.

A risk assessment is generally undertaken to determine the level of risk for a specific structure, in order to make a comparison with a pre-determined value of “acceptable risk”. Protection measures, at an appropriate lightning protection level (LPL), are then implemented to reduce the risk to or below the acceptable risk. The lightning protection level determines the spacing of the mesh, radius of rolling sphere, protective angle, etc.

It should be noted that while lightning protection is typically implemented as a bonded network of air-terminals and down-conductors, other methods are permitted:

- To limit touch and step potential risks:
 - Insulation of exposed conductive parts
 - Physical restriction and warning signs
- To limit physical damage:
 - Fire proofing, fire extinguishing systems, protected escape routes

3.1. RISKS

To understand why typical conventional lightning protection systems require rigorous equipotential bonding and earthing, it is important to understand how the risk of injury due to step/touch potentials and side flashing occur.

3.1.1. STEP POTENTIAL

When lightning current is injected into the earth, a large voltage gradient builds up around the earth electrode with respect to a more distant point. The earth can be imagined as a sequence of overlapping hemispheres. The greater the distance from the electrode, the larger the surface area of the hemisphere and the more parallel paths through the soil. Thus the voltage rise is greatest near the electrode where current density is highest.

The normal step distance of a person is near to 1 meter. At the time of discharge being close to the earth electrode means the voltage differential across this distance can be large enough to be lethal – depending upon circumstances such as condition of footwear, etc, substantial current can flow through one lower leg to the other.

In the case of animals, a larger risk exists. The distance between the front and rear legs of larger animals can be in the order of 2 meters, and the current path flows through the more sensitive region of the heart.

The hazard is considered to be reduced to tolerable level if:

- The probability of persons approaching, or duration of presence within 3 m of the down-conductor is very low – limiting access to the area can be a solution
- Step potential is reduced by use of ≥ 5 k ohm.m insulating barrier such as 50 mm of asphalt or 150 mm of gravel within 3 m of the electrode
- An equipotential earthing system such as mesh system is correctly used

It is also good practice for the upper section of the conductor entering into the earth to be insulated. Heat shrink (2 mm polyethylene) or 4 mm thick PVC protecting the first 2-3 m of conductor/electrode is sufficient to reduce step potential hazards. Where a conductor is insulated and buried, any insulated portion should **not** be considered as contributing to the earthing requirements of **Section 12**.

3. Introduction To Protection Methods & Risks (continued)

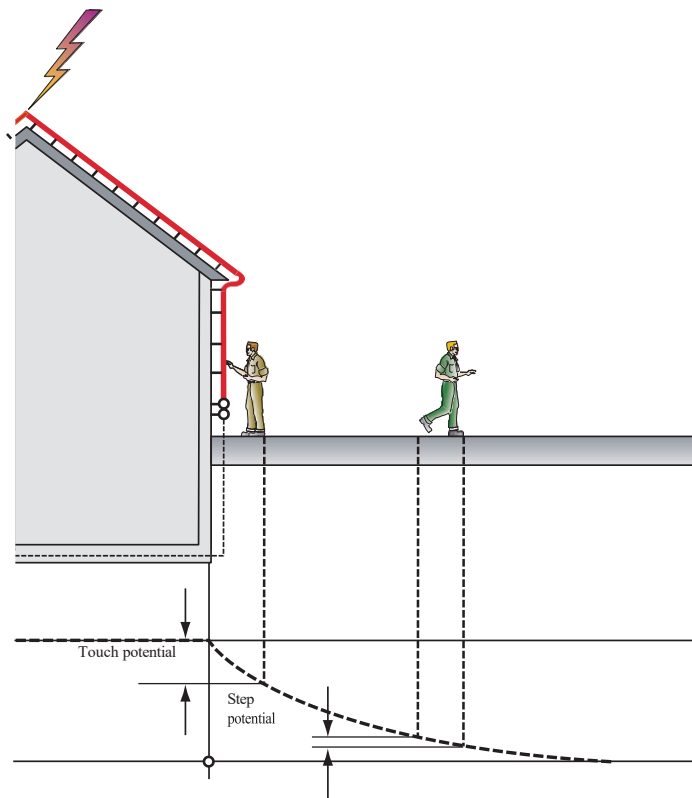


Figure 10. Step and touch voltage gradients.

3.1.2. TOUCH POTENTIAL

Touch potential is due to a similar reason as step potential, but the voltage differential being considered is that which exists between the hand and (generally) feet. The risk of electrocution due to touch potential is greater than for step potential, as the passage of current flows close to the heart region.

The hazard is considered to be reduced to tolerable level if:

- The probability of persons approaching, or duration of presence is very low – limiting access to the area can be a solution
- Natural down-conductors are used where extensive metal framework or steel work is interconnected
- A surface layer with $\geq 5 \text{ k ohm.m}$ insulating barrier such as 50 mm of asphalt or 150 mm of gravel is used
- The down-conductor is insulated with at least 100 kV 1.2/50 μs impulse insulation (3 mm PVC)

3.1.3. SIDE FLASHING

All down-conductors have a resistance and, more importantly, inductance. During the lightning flash the rapid rate of current rise can cause the inductive voltage rise of the conductor to reach a magnitude where sufficient voltage exists for the conductor to flashover to a nearby conductive and earthed object.

Side flashing can be controlled by:

- Using a number of parallel down-conductors to reduce the current in each
- Ensuring the separation distance between the two objects is sufficient not to break down the intervening medium; or
- Bonding to the object to eliminate the potential difference (the object may carry a partial lightning current)

The down-conductor and bonding requirements of the standard address these issues.

4. Risk Management

4 RISK MANAGEMENT

IEC 62305-2 provides a lightning risk management procedure that provides a tolerable limit of risk, methods to calculate the actual risk, and then evaluates the protection methods required to reduce the actual risk to be equal or lower than the tolerable risk. The main outcome from this risk assessment is to determine if lightning protection is required and if so, to select the appropriate

lightning class. The lightning class determines the minimum

lightning protection level (LPL) that is used within the lightning protection design.

Lightning protection can be installed even when the risk

management process may indicate that it is not required. A greater level of protection than that required may also be selected.

It should be noted that the IEC 62305-2 document is over 100 pages in length and is extremely comprehensive and complex. A full manual analysis of all risks can take tens of hours to complete. Therefore for most situations a reduced analysis is conducted, preferably with an electronic tool. For this purpose, the IEC standard comes with software, and additional third-party software is also available.

For complex or high risk structures/situations, a more detailed analysis should be considered using the full standard. This would include, but is not limited to:

- Locations with hazardous or explosive materials
- Hospitals or other structures where failure of internal systems may cause a life hazard

Note that with the national implementation of the BS EN 62305-2 Risk Management standard some minor adjustments to the procedures and values has occurred to better reflect the localized conditions and acceptable local tolerable risk. Use the national standard appropriate to the country of installation, or select a national standard where that country experiences similar lightning risk (ground flash density/thunderdays) and similar social/economic values.

4.1. OVERVIEW OF RISK ANALYSIS

It is beyond the scope of this document to describe the full risk management requirements. Conceptually the risk analysis follows the general process of:

1. Identifying the structure to be protected and its environment
2. Evaluating each loss type and associated risk (R_1 to R_3)
3. Comparing R_1 to R_3 to the appropriate tolerable risk R_T to determine if protection is needed
4. Evaluating protection options so R_1 to $R_3 \leq R_T$

Note that separate R_T figures exist for risk of losses R_1 to R_3 .

Lightning protection is required such that R_1 , R_2 & R_3 are all equal or lower than the respective tolerable risk (R_T).

Lightning protection may also be justified upon the economic risk R_4 and the respective economic benefit. A separate procedure in IEC 62305-2 is followed for this analysis.

Each of the following risks are broken down into individual risk components (sub categories), which are then evaluated with regard to direct and indirect lightning effects upon the structure and on the services. This requires the computation of the number of dangerous events, which is related to the structure size and lightning flash density.

The simplified analysis software considers:

- Structure's dimensions
- Structure's attributes
- Environmental influences
- Effect of services entering facility
- Existing protection measures

The simplified software is IEC 62305-2 compliant, but is conservative in nature. That is, worst case or conservative values are assumed. In situations where multiple identical structures are to be constructed, it may be appropriate to conduct a full risk analysis in case a small economic saving can be obtained and applied across the many structures.

Loss	Risk to Structure	Risk to Services
L1 - loss of human life	R_1 - Risk of loss of human life	
L2 - loss of essential services	R_2 - Risk of loss of essential services	R'_2 - Risk of loss of essential services
L3 - loss of cultural heritage	R_3 - Risk of loss of cultural heritage	
L4 - economic loss	R_4 - Risk of economic loss	R'_4 - Risk of economic loss

Table 6. Risk assessment losses.

4. Risk Management

4.1.1. SOURCES OF DAMAGE, TYPE OF DAMAGE, TYPE OF LOSS AND RISK OF LOSS

For those interested in a better understanding of the risk management process, or a desire to manually calculate a structure's risk, the remaining sections of this chapter provide an introduction to the topic. It should be helpful in understanding the effect of selection of parameters in risk assessment tools based on IEC 62305-1/2, and if a manual assessment is to be undertaken, help introduce the concepts of the standards which should be followed.

It is important to understand the sources of damage, types of damage and types of losses as the procedure to assess the risk evaluates various combinations considering structure, contents, services and environment with the source and type of damage.

IEC 62305-1 introduces the concepts of sources of damage (**Figure 11**) where:

- S1 - Lightning flash to the structure
- S2 - Lightning flash near the structure
- S3 - Lightning flash to the services
- S4 - Lightning flash near to the services

With the possible sources of damage due to lightning flash defined, three possible types of damage are identified:

- D1 - Injury of living beings (humans and animals) due to touch and step potential
- D2 - Physical damage (fire, explosion, mechanical destruction, chemical release)
- D3 - Failure of internal electrical/electronic systems due to lightning electromagnetic impulse

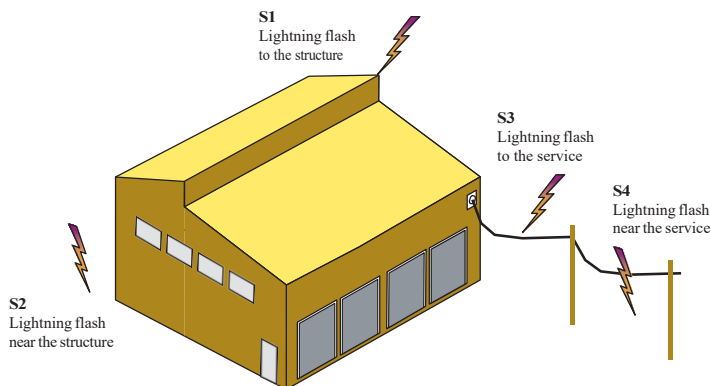


Figure 11. Sources of damage

With each type of damage, four types of losses are identified:

- L1 - Loss of human life
- L2 - Loss of essential service to the public
- L3 - Loss of cultural heritage
- L4 - Economic loss (structure and its contents, service and loss of activity)

Care is required with the term “services”, as it is dependant upon its context within the standard. This may refer to the physical services connected to the building (water, power, gas, fuel or data/telecommunications), or services provided to the public (e.g. information services). The scope of services to the public includes any type of supplier who, due to lightning damage, can not provide their goods or “service” to the public. For example a supermarket closed due to damage to cash register/check-out systems, or an insurance company unable to transact business due to phone or website failure.

Table 7 summarizes the types of damage and types of loss for each of the four sources of damage [from IEC 62305-1 Table 3]. For each of the first three types of losses (L1, L2 & L3), the procedure of IEC 62305-2 evaluates the risk of these respective losses (R_1 , R_2 & R_3) and compares them to tolerable levels. For Loss L4, the economic cost of the loss, with and without lightning protection, is compared to the cost of the protection measures.

Table 8 details the types of damages and losses associated with a service. As the loss and calculation of the risk of loss is different to that of the structure, the convention L'2 & L'4 are used to differentiate these losses.

4. Risk Management (continued)

Source of damage (Point of strike)	Type of damage	Type of loss
S1 Lightning flash to the structure	D1 - Injury	L1 – Loss of human life L4 – Economic loss ⁽¹⁾
	D2 – Physical damage	L1 – Loss of human life ⁽²⁾ L2 – Loss of service L3 – Loss of heritage L4 – Economic loss
	D3 – Failure of systems	L1 – Loss of human life ⁽²⁾ L2 – Loss of service L4 – Economic loss
S2 Lightning flash near the structure		L1 – Loss of human life
	D3 – Failure of systems	L2 – Loss of service L4 – Economic loss
S3 Lightning flash to the services	D1 - Injury	L1 – Loss of human life L4 – Economic loss ⁽¹⁾
	D2 – Physical damage	L1 – Loss of human life L2 – Loss of service L3 – Loss of heritage L4 – Economic loss
	D3 – Failure of systems	L1 – Loss of human life ⁽²⁾ L2 – Loss of service L4 – Economic loss
S4 Lightning flash near to the services		L1 – Loss of human life ⁽²⁾
	D3 – Failure of systems	L2 – Loss of service L4 – Economic loss

Notes:

⁽¹⁾ Only for properties where animals may be lost

⁽²⁾ Only for structures with risk of explosion and for hospitals or other structures where failure of services or internal systems endangers human life

Table 7. Damages and losses in a structure for different sources.

Source of damage (Point of strike)	Type of damage	Type of loss
S1 Lightning flash to the structure	D2 – Physical damage	
	D3 – Failure of systems	
S3 Lightning flash to the services	D2 – Physical damage	L'2 – Loss of service
	D3 – Failure of systems	L'4 – Economic loss
S4 Lightning flash near to the services	D3 – Failure of systems	

Table 8. Damages and losses in a structure for different sources.

4. Risk Management (continued)

4.1.2. RISK MANAGEMENT PROCEDURE & TOLERABLE RISK

For each of the losses L1 to L3, the risk of each loss is determined ($R_{1\text{ to }3}$). The risk of each loss is then compared to a tolerable risk:

- If the calculated risk is equal or less than the respective tolerable risk (RT), then lightning protection is not required
- If the calculated risk is higher than the tolerable risk then protection is required. Protective measures should be evaluated to reduce the calculated risk to be equal or less than the tolerable risk

The flow chart in **Figure 12** shows the general procedure, while **Table 9** provides the tolerable risks as provided by IEC and BS standards. The tolerable risk is expressed in the form of number of events per year and is given in engineering units (e.g. 10^*). **Table 9** also expresses these in the format of x in y events (per year).

Types of loss	$R_T(y^{-1})$	
	IEC 62305-2	BS EN 62305-2
Loss of human life	10^{-5} (risk of 1 in 100,000)	10^{-5} (risk of 1 in 100,000)
Loss of service to the public	10^{-3} (risk of 1 in 1,000)	10^{-4} (risk of 1 in 10,000)
Loss of cultural heritage	10^{-3} (risk of 1 in 1,000)	10^{-4} (risk of 1 in 10,000)

Table 9. Tolerable risk R_T

4. Risk Management (continued)

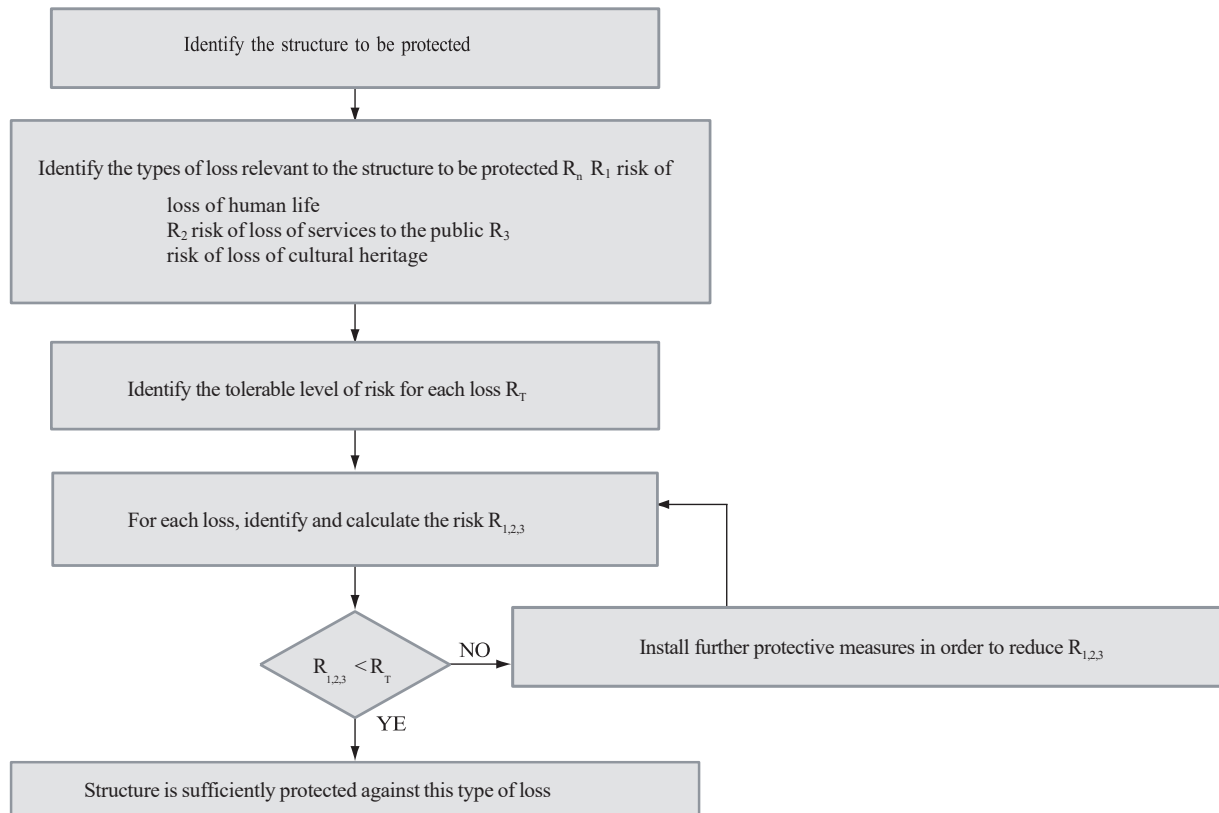


Figure 12. Damages and losses in a structure for different sources.

4. Risk Management (continued)

Risk Component	Source of damage	Type of damage	Formula
R_A	S1	D1	$R_A = N_D \times P_A \times L_A$
R_B	S1	D2	$R_B = N_D \times P_B \times L_B$
R_C	S1	D3	$R_C = N_D \times P_C \times L_C$
R_M	S2	D3	$R_M = N_M \times P_M \times L_M$
R_U	S3	D1	$R_U = (N_L + N_{DA}) \times P_U \times L_U$
R_V	S3	D2	$R_V = (N_L + N_{DA}) \times P_V \times L_V$
R_W	S3	D3	$R_W = (N_L + N_{DA}) \times P_W \times L_W$
R_Z	S4	D3	$R_Z = (N_I + N_L) \times P_Z \times L_Z$

Table 10. Risk assessment losses.

4.1.3. RISK COMPONENTS

The risks $R_{1 \text{ to } 4}$ are calculated from the sum of the appropriate risk components:

Risk of loss of human life:

$$R_1 = R_A + R_B + R_C + R_M + R_U + R_V + R_W + R_Z$$

⁽¹⁾ Only applicable to structures with risk of explosion and hospitals or other structures where failure of internal systems immediately endangers human life.

Risk of loss of services to the public:

$$R_2 = R_B + R_C + R_M + R_V + R_W + R_Z$$

Risk of loss of cultural heritage:

$$R_3 = R_B + R_V$$

Risk of loss of economic value:

$$R_4 = R_A + R_B + R_C + R_M + R_U + R_V + R_W + R_Z$$

⁽²⁾ Only for structures where animals may be lost.

Each of the components is obtained using further calculations, sub-calculations and reference tables based on the general equation:

$$R_x = N_x \times P_x \times L_x$$

Where

N_x = number of dangerous events per year

P_x = probability of damage to structure

L_x = amount of loss

The number of dangerous events per year is primarily based upon the structure dimensions, length and type of service and the ground flash density. The physical dimensions of the structure and service are used to calculate the effective lightning capture area, and the ground flash density is used to determine the probable number of events per year. Several graphical and calculation

methods are provided by the standard.

The probability of damage is obtained from the given tables in the standard, with some simple calculations being required.

The amount of loss is also obtained from the given tables in the standard with calculations being required.

6. Design Process

5 LIGHTNING PROTECTION ZONES

Lightning protection zones (LPZ) are used to define the electromagnetic environment. The zones may not necessarily be physical boundaries (e.g. structure walls). The zones are areas characterized according to threat of direct or indirect lightning flashes and full or partial electromagnetic field.

LPZ 0 (Zero) is considered the “lowest” zone, LPZ 1, 2, 3, being respectively “higher”.

It is the design and placement of the LPS that ensures the structure and internal contents are within an LPZ_{0b} zone.

Internal systems are required be located within an LPZ 1 (or higher) zone. As seen from **Figure 13**, electrical/electronic equipment located in LPZ 1 (or higher) and connecting to external services (located in LPZ 0_b or LPZ 0_a) require surge protective devices to limit energy being conducted from zones exposed to direct lightning or full/partial electromagnetic fields or surge current. Refer to **Sections 10.3 & 12** for SPD requirements. Non electrical services (e.g. water, gas, etc) meet this requirement by the application of the bonding requirements also detailed in **Section 10.3 & 12**.

Lightning protection zone (LPZ)	Exposure threats		
	Lightning flash	Lightning current or induced current	Electromagnetic field
LPZ 0 _A	YES	Full	Full
LPZ 0 _B	NO	Partial	Full
LPZ 1	NO	Limited	Partial
LPZ 2	NO	Reduced below LPZ 1	Reduced below LPZ 1

Table 11. Lightning protection zones.

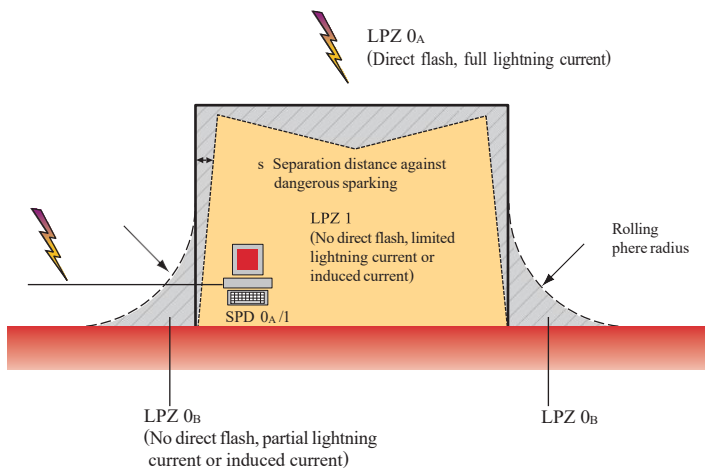


Figure 13. Lightning protection zones.

6. Design Process

6 DESIGN PROCESS

The lightning protection design process involves a number of design steps as illustrated by **Figure 14**. Depending upon the specifics of the structure, cost, architectural and aesthetic concerns, the process may be somewhat iterative.

An important part of the design process is compliance with separation distance requirements. This determines what external and internal metallic items need to be bonded to the LPS.

Separation distance requirements also apply to internal electrical and electronic circuits; thus is especially important to consider the existing and future use of the building. The separation distance requirements are determined by the lightning protection level, the position of the LPS and the number of down-conductors. To simplify conformance to the separation distance requirements, alternative down-conductor location(s) and increased number may be required.

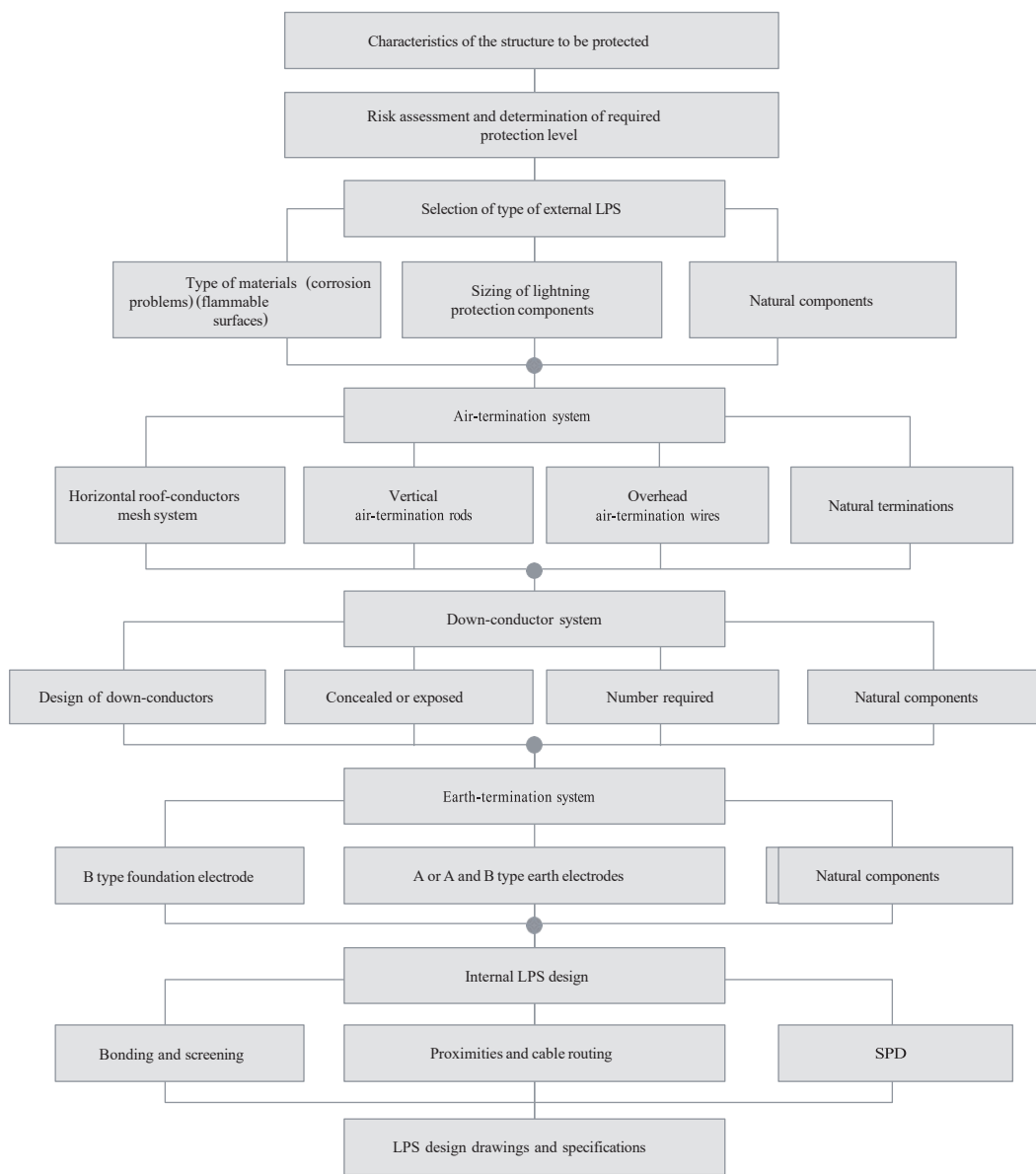


Figure 14. Lightning protection design process.

7. Material requirements



Figure 15. Violation of separation distance due to poor design and later additions to structure.

7. MATERIAL REQUIREMENTS:

All lightning protection materials should conform to EN 50164-1 and EN 50164-2 Lightning Protection Components requirements. The exceptions to these requirements are non-current carrying devices such as down-conductor fixings (clips), anti-vandal guards and mechanical supports. The IEC and EN standards prescribe the minimum material requirements as summarized in **Table 12**. It should be noted that the standards do not prescribe any relative performance

advantages between these choices. All are adequate to conduct the lightning current. When considering service life, aesthetics, galvanic compatibility with building materials and ease of installation, there is generally a preferred clear choice of material for a given structure.

7.1. COPPER VERSUS ALUMINUM

A conductor material should be chosen that is compatible with the surface it is to be located upon and that which it is to connect to. As a typical lightning protection system requires frequent bonds to nearby metallic items, compatibility with this should also be assessed. Additionally the aesthetics of eventual white corrosion of aluminum or green verdigris of copper should be considered – PVC covering may be a solution to this problem.

Aluminum has the advantage of lower cost. Its lighter weight is also a benefit to the installer. However, aluminum is less compatible with many building materials and can not be buried in the ground. Therefore, most lightning protection systems are entirely copper or utilize an upper aluminum portion connecting to a copper earth termination system. As aluminum and copper are not compatible, a bimetallic joint should be used to interconnect these two materials.

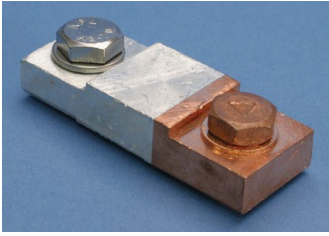
Material	Arrangement	Minimum cross section (mm ²)	Notes
Copper & tin plated copper	Tape	50	2 mm minimum thick
	Solid round ⁽¹⁾	50	8 mm diameter
	Stranded	50	1.7 mm minimum diameter of each strand
	Solid round air-terminal ⁽²⁾	200	16 mm diameter
Aluminum & Aluminum alloy	Tape ⁽³⁾	70	3 mm minimum thickness
	Solid round	50	8 mm diameter
	Stranded	50	1.7 mm minimum diameter of each strand
	Solid round air-terminal ⁽²⁾	200	
Galvanized & stainless steel	Refer to standard		
Natural components	Refer to Section 8		

Notes:

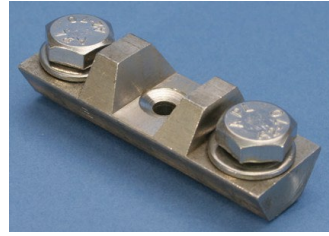
- ⁽¹⁾ 50 mm² (8 mm diameter) may be reduced to 28 mm² (6 mm diameter) where mechanical strength is not an essential requirement
- ⁽²⁾ For air-terminals of 1 m or less, 10 mm diameter may be used
- ⁽³⁾ 50 mm² with a minimum 2.5 mm thickness may be used with aluminum alloy
- ⁽⁴⁾ Materials may be covered with PVC for aesthetic purposes
- ⁽⁵⁾ Refer to **Section 21** for review of differences in requirements between EN 50164-2 and IEC 62305-3

Table 12. Minimum material dimensions for conductors and air-terminations.

7. Material requirements (continued)



Bimetallic connector



Stainless steel connector

Figure 16. Bimetallic connectors

There are specific cautions on the use of aluminum, the effects of which can generally be overcome with the use of PVC covered aluminum (with the exception of the last two situations):

- Aluminum is prone to corrosion when in contact with limestone, plaster, mortar and cement. For this reason, aluminum conductors should not be placed in direct contact with such surfaces. Stand-off fixings can be used, or PVC covered aluminum conductors used
- Aluminum is prone to corrosion in marine or sea-side environments
- Aluminum should not be installed where it will be exposed to water run-off from copper (or copper alloy) surfaces
- Aluminum should not be installed on surfaces coated with alkaline based paint
- Aluminum should not be installed in locations subject to excessive moisture (i.e. in gutters, or on surfaces where water may be retained)
- Aluminum should not be directly connected to copper conductors (refer to **Section 7.2** for further metal cautions)
- Aluminum should not be buried in the ground



Figure 17. Stand-off bases are used to distance aluminum conductors from incompatible surfaces.

While copper is generally considered to be the most appropriate default choice of material, care should be taken in areas with sulphurous atmospheres (e.g. smoke stacks), where stainless steel or lead covered copper may be more appropriate. Copper should not be installed above galvanized, zinc or aluminum parts where water run-off occurs (unless parts are protected such as by PVC covering). Water run-off from the copper surface carries fine copper corrosion particles, which when deposited on lower galvanized, zinc or aluminum parts may result in severe corrosion. Direct contact of the two materials is not required for corrosion to occur.

7.2. USE OF DISSIMILAR METALS

Galvanic corrosion occurs when two dissimilar metals are in contact with each other in the presence of an electrolyte. In this situation, one metal becomes the anode and the other the cathode. The anode will tend to go into solution and therefore corrode. The electrolyte can be water with impurities from the air, other surfaces or from the metal itself (refer to **Section 7.1** regarding cautions on water run-off).

Table 14 shows the potential difference between dissimilar metals. Combinations of metals with potential differences above 0.5 V should be rejected to avoid excessive corrosion. IEC 60943-1998 standard recommends that differences over 0.35 V should be avoided.

One method of reducing the effects of corrosion is to use plating of one or both of the metals to reduce the electrochemical potential difference. Commonly, tin plated copper conductors are used for this purpose. Tin plating also has the advantage of stopping the appearance of green verdigris coating and reducing the chance of theft (as the conductor no longer looks like copper). Copper can be purchased by the coil tin plated, or bare copper used and the end prepared and soldered before connection.

For example, a bare copper conductor should not be directly connected to steel, as the electrochemical potential difference is 0.53 V (≥ 0.5 V). However, if the copper is tin plated then the difference becomes that of tin (0.24 V), which is acceptable.

Structure material	Most suitable LPS material
Aluminum	Aluminum
Cast iron	Aluminum or tin plated copper
Copper	Copper
Gunmetal, bronze, etc	Copper
Steel (galvanized)	Aluminum
Steel (stainless)	Aluminum or tin plated copper
Steel	Aluminum
Tin	Aluminum or copper
Zinc	Aluminum

Table 13. Selection of compatible materials.

7. Material requirements (continued)

		Anodic (-)																									
		Silver	Nickel	Monel metal	Cupro-nickel (70-30)	Copper	Silver solder	Bronzes	Gunmetal	Brasses	Stainless steels	Tin	Tin-lead solder	Silver-lead solder	Lead	Grey cast iron	Steels (not stainless)	Aluminum alloys	Aluminum	Cadmium	Galv. iron or steel	Zinc base alloys	Zinc	Magnesium alloys			
Cathodic (+)	Silver				0	0.15	0.17	0.19	0.19	0.21	0.23	0.25	0.26	0.33	0.47	0.48	0.51	0.56	0.71	0.72	0.77	0.77	0.79	1.09	1.10	1.11	1.59
	Nickel				0	0.02	0.04	0.04	0.06	0.08	0.1	0.11	0.16	0.32	0.33	0.36	0.41	0.53	0.57	0.62	0.62	0.64	0.94	0.95	0.96	1.44	
	Monel metal				0	0.02	0.02	0.04	0.06	0.08	0.09	0.16	0.3	0.31	0.34	0.39	0.54	0.55	0.60	0.60	0.62	0.92	0.93	0.94	1.42		
	Cupro-nickel (70-30)				0	0	0.02	0.04	0.06	0.07	0.14	0.28	0.29	0.32	0.37	0.52	0.53	0.58	0.58	0.60	0.90	0.91	0.92	1.40			
	Copper Silver solder					0	0.02	0.04	0.06	0.07	0.14	0.28	0.29	0.32	0.37	0.52	0.53	0.58	0.58	0.60	0.90	0.91	0.92	1.40			
	Bronzes						0	0.02	0.04	0.05	0.12	0.26	0.27	0.3	0.35	0.50	0.51	0.56	0.56	0.58	0.88	0.89	0.90	1.38			
	Gunmetal (red bronze)							0	0.02	0.03	0.1	0.24	0.25	0.28	0.33	0.48	0.49	0.54	0.54	0.56	0.86	0.87	0.88	1.36			
	Brasses								0	0.01	0.08	0.22	0.23	0.26	0.31	0.46	0.47	0.52	0.52	0.54	0.84	0.85	0.86	1.34			
	Stainless steel									0	0.07	0.21	0.22	0.25	0.3	0.45	0.46	0.51	0.51	0.53	0.83	0.84	0.85	1.33			
	Tin										0	0.14	0.15	0.18	0.23	0.38	0.39	0.44	0.44	0.46	0.76	0.77	0.78	1.26			
	Tin-lead solder											0	0.01	0.04	0.09	0.24	0.25	0.3	0.3	0.32	0.62	0.63	0.64	1.12			
	Silver-lead solder												0	0.03	0.08	0.23	0.24	0.29	0.29	0.31	0.61	0.62	0.63	1.11			
	Lead													0	0.05	0.2	0.21	0.26	0.26	0.28	0.58	0.59	0.60	1.08			
	Grey cast iron														0	0.15	0.16	0.21	0.21	0.23	0.53	0.54	0.55	1.03			
	Steels (not stainless)															0	0.01	0.06	0.06	0.08	0.38	0.39	0.4	0.88			
	Aluminum alloys																0	0.05	0.05	0.07	0.37	0.38	0.39	0.87			
	Aluminum																	0	0.02	0.32	0.33	0.34	0.82				
	Cadmium																		0	0.3	0.31	0.32	0.80				
	Galv. iron or steel																			0	0.3	0.31	0.32	0.80			
	Zinc base alloys																				0	0.01	0.02	0.50			
	Zinc base alloys																					0	0.01	0.49			
	Zinc base alloys																						0	0.45			

7. Material requirements (continued)

Magnesium alloys

0

Table 14. *Electrochemical series (volts).*

7. Material requirements (continued)

Tin plated copper should be used for connections to:

- Lead
- Grey cast iron
- Steel (stainless steel connections do not need to be tinned)
- Aluminum
- Cadmium

7.3. PVC COVERED AND CONCEALED CONDUCTORS

Within the United Kingdom, conductors with approximately 1 mm of PVC covering are often used due to:

- Aesthetic reasons - to match the conductor to the building color
- Corrosion - to hide the effects of aluminum conductor corrosion or to reduce corrosion of aluminum in close proximity to concrete, mortar, etc

While the British Standard BS 6651 notes that PVC covering limits the effectiveness when conductors are used as air-terminations, it is common to see air-termination networks that are basically insulated. This does severely compromise the performance of the air-termination.

The IEC standards do not specifically address PVC covered conductors. However, in the interest of improved performance, it is strongly recommend not to use PVC covered conductors where the rolling sphere method would indicate that the mesh is likely to be a potential lightning termination point. Alternatively, the addition of air-terminals (Franklin rods) could be considered to provide protection via the rolling sphere method.

The IEC standard does permit air-termination conductors to be installed under non-conducting roofs (e.g. tiles). However, there is a risk of damage to tiles should they be the point of strike, with possible water damage then occurring. Installation under roofs should not considered where combustible materials are close by. If the air-termination conductor is to be concealed then the preference is to install short finials that protrude above the roof and are not more than 10 m apart. Metal strike pads can also be used, spaced no more than 5 m apart.

7.4. TAPE, VERSUS SOLID ROUND, VERSUS STRANDED

The many choices of conductor geometry exist in part due to historical precedent, standard specifications, installer preference and manufacturer product differentiation.

Conductor geometry	Description
Tape 	<ul style="list-style-type: none"> • Bends in one plane only – thus good for maintaining a visually straight line for down-conductors. However, difficult to route around complex shapes where bends in two axis are required • Low profile
Solid Round 	<ul style="list-style-type: none"> • Easy to install – can be bent in any plane • Straightening tool may be required • Less obvious to see than wider 25 x 3 mm tape
Stranded (smooth weave) 	<ul style="list-style-type: none"> • Does not have memory, thus can be applied directly from roll • Once bent it stays in shape • Does not suffer from expansion and contraction problems of other conductors • Difficult to make 100% straight
Traditional stranded conductor 	<ul style="list-style-type: none"> • Has memory, therefore needs to be uncoiled and straightened before use • When bent, it untwines or frays • Not well suited to lightning protection applications

Table 15. Typical conductor attributes.

8. Material requirements (continued)

8. NATURAL COMPONENTS

Natural conductive components can be used as an integral part of the lightning protection system. Natural components are typically metallic structural items that will not be modified during the life of the structure, such as reinforcing steel, metal framework and roofing/cladding. Natural components must meet minimum material requirements and be electrically continuous with secure interconnections between sections such as brazing, welding, clamping, seaming, screwing or bolts.

If the electrical continuity of the natural component can not be guaranteed, then separate dedicated down-conductors should be used.

The requirements for natural air-terminations differ from natural down-conductors. Down-conductors and air-terminations need to withstand the ohmic heating and electromechanical/magnetic forces, but air-terminations also need to withstand the heat of the lightning plasma arc.

Material	Minimum thickness (mm)	
	Puncturing, hot spot or ignition not permitted	Puncturing, hot spot or ignition permitted
Lead		2
Steel	4	0.5
Titanium	4	0.5
Copper	5	0.5
Aluminum	7	0.65
Zinc		0.7

Note: A thin coating of paint, 1 mm of asphalt or 0.5 mm PVC covering is permitted.

Table 16. Minimum material thickness of metal pipes and sheets for natural air-terminations.

Table 16 provides the thickness requirements for natural air-terminations. Where combustible materials are not present, and water ingress can be tolerated from a puncture due to lightning, then thinner material is permitted for air-terminations.

If the materials do not meet these requirements, then they must be protected by the lightning protection system.

Metal pipes and tanks on roofs can be used, provided they meet the requirements of **Table 12** and **Table 16**. Refer to the standard for requirements of tanks and piping that contain combustible or explosive mixtures. It is not desirable to use vessels and pipe work which contains gas or liquids under high pressure or flammable gas or liquids.

8.1. METALLIC FACADES, PROFILES, RAILS, ETC

Metallic facades, profiles, etc, may be used as down-conductors provided they:

- Are electrically continuous in the vertical direction
- Have dimensions equal or exceeding **Table 16** (metal sheets or metal pipes thickness must not be less than 0.5 mm)

8.2. USE OF STEELWORK

Use of steel is permitted for down-conductors provided that:

- A major part of vertical and horizontal connections are welded or securely connected
- Dimensions equal or exceed **Table 16**

8.3. USE OF REBAR IN REINFORCED CONCRETE

Use of rebar for down-conductors is permitted provided that:

- The overall resistance from top to ground level is less than 0.2 ohms
- A major part of vertical and horizontal connections are welded or securely connected
- Construction is supervised – this method is not recommended for existing buildings where the connections were not planned/documentated and inspected prior to concrete pour

To measure the overall resistance of the reinforcing steel connection it is recommended that a 4 pole resistance measuring device be used (milli-ohm meter). Such a device has separate current and potential test leads, thereby effectively eliminating the length of the test leads from the measurement result. Generally the instrument is located at the top or bottom of the connection to be measured and then two insulated test leads are run to the other end. The 4 pole test method also effectively eliminates the connection resistance of the test leads to the reinforcing steel. It is important the current leads are placed on the outside of the potential leads when testing. Generally 50 mm separation or more between these two probes is required. Refer to manufacturer's instructions for test requirements. Most modern meters used for this purpose also can be used for resistivity measurements (refer to **Section 14.7.1**).

The internal interconnection of the rebar is recommended to be welded (where permitted) with a parallel overlap of 50 mm and weld length of not less than 30 mm. nVent's LENTON mechanical splices also provide an acceptable electrical interconnection.

8. Natural components (continued)

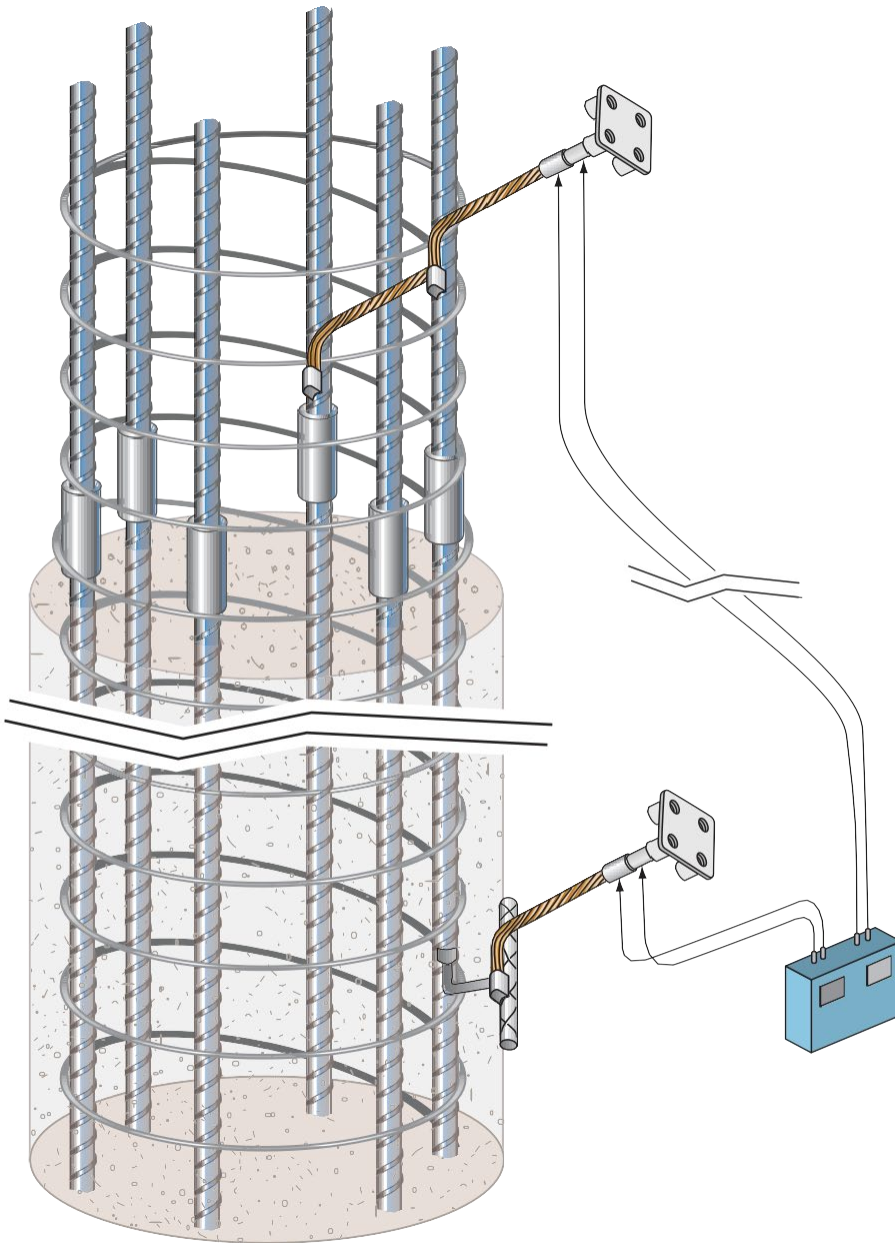


Figure 18. 4 pole test method for determining reinforcing acceptability.

While the interconnection by wire tie is permitted (where length of overlaps must be at least 20 times the diameter), evidence shows that this is not suitable for a lightning-carrying connection, i.e. high current-carrying connections. The upper connection of the external LPS to the internal rebar carries the highest current density. It is important that this connection be secure, thus wire tie is not sufficient. nVent ERICO Cadweld or welded connections are recommended. Where mechanical clamps are used, they should be approved to EN 50164-1 and either two bonding conductors

should be used, or one conductor with two clamps connecting to separate rebars.

For the lower connection where tails are taken from rebar to the earth electrodes, the lower current density allows the use of a single Cadweld, welded connection or clamp.

Compatibility between connected metals also needs to be considered.

8. Natural components (continued)

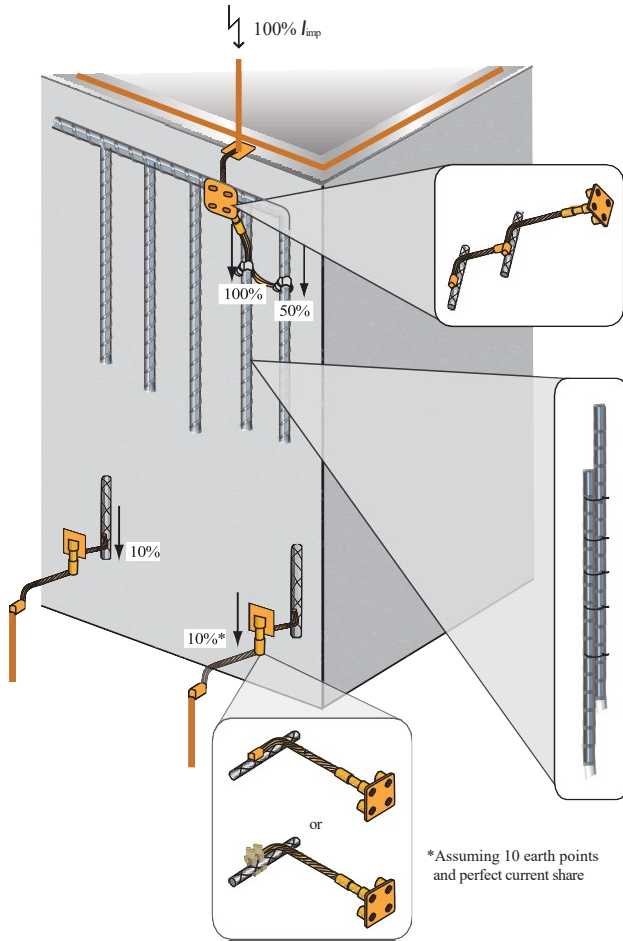


Figure 19. Use more secure connections for high current density locations.

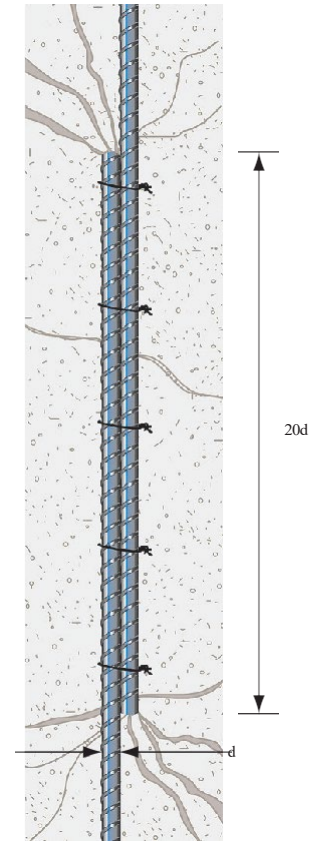


Figure 21. Overlap requirements for rebar.

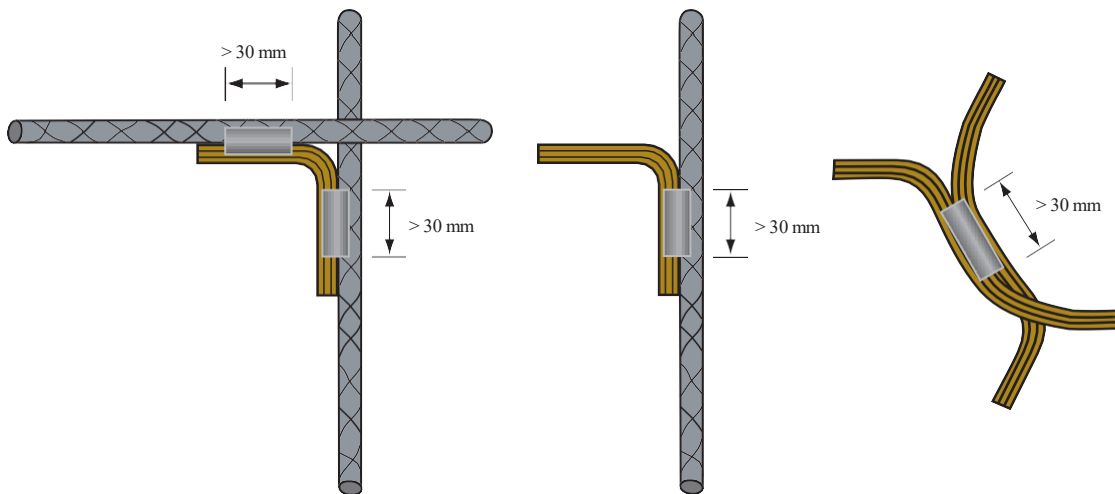


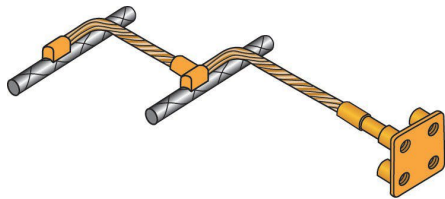
Figure 20. Rebar welding requirements for connections in concrete.

8. Natural components (continued)

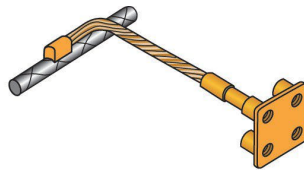


Figure 22. nVent LENTON termination of rebar provides good electrical connection.

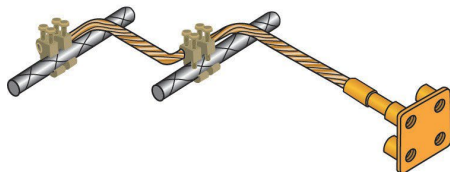
Suitable for connection to air termination



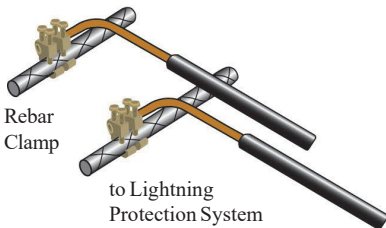
Suitable for connection to ground electrode



Cadweld Exothermic connections



Mechanical connection to EN50164-1



Rebar
Clamp

to Lightning
Protection System

Figure 23. Rebar clamps and Cadweld for connection to concrete reinforcing steel.

8. Natural components (continued)

For ease of construction and installation, a grounding plate is recommended for connection of the LPS to the concrete member. If a grounding plate is not used, then attention should be given to corrosion protection at the air/concrete interface. If the rebar is brought out then 100 mm of silicon rubber or bitumen covering should be used. Interface corrosion protection is not required for copper, PVC covered copper or stainless steel conductors.

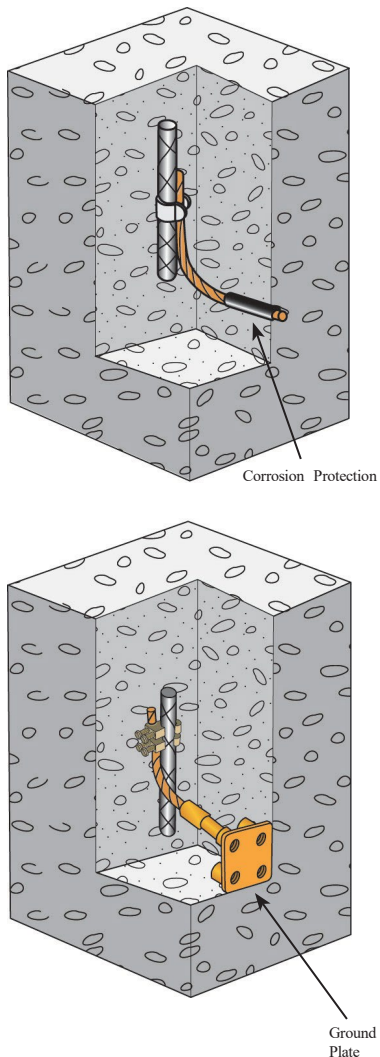


Figure 24. Ground plates are convenient and eliminate the need for corrosion protection.

If welding is not permitted to the rebar, then an alternative is to use a dedicated lightning protection down-conductor that is embedded in the concrete. This conductor should be wire tied or clamped periodically to the rebar.

General practice is to nominate specific rebars in the main structural columns as down-conductors, and to ensure that these are continuous through the entire route to ground. The connection path should be vertical.

Full interconnection should be made to horizontal elements such as floors and walls. For structures such as data processing centers this is more critical, and precast façade elements should also be bonded to provide effective electromagnetic shielding.

8.3.1. PRECAST CONCRETE

Precast concrete rebar is permitted to be used as above. However precast members such as floors do not normally have external access to rebar connections. For full interconnection, terminations should be provided for connection to columns and other members.

8.3.2. PRESTRESSED CONCRETE

Prestressed reinforced concrete is most commonly used for flooring, and rarely in vertical columns - hence it is not often used as a natural down-conductor. If it is to be used, care is recommended due to possible unacceptable mechanical consequences resulting from the lightning current or interconnection to the LPS. Only cables of 10 mm diameter or greater should be used, and several parallel cables should be used.

Note that prestressed concrete is often used for facades, and in the construction process the stressing cables are often isolated from the other structural members. Should a side flash occur, there may be cracking of the facade with damage to the corrosion protection concrete grout used around the stressing cable. These cables are highly susceptible to corrosion. In such situations, both ends of the cables should be bonded to the LPS.

9. Design methods

9. DESIGN METHODS

The rolling sphere method, mesh method and protection angle method are used to determine the required positioning of the lightning protection air-terminations. While there are limits on the application of the protection angle and mesh methods, generally the standard considers the three methods as equivalent.

The rolling sphere method is recommended as the most universal method, while the mesh method is more suitable for the protection of flat surfaces. The protection angle method can only be used with limited vertical distances. Different design methods can be applied to different regions of a single lightning protection system, provided the zones afforded by each method overlap to protect the entire structure.

Any of these methods can be used to determine placement of the air-terminations. Permitted air-terminations are:

- Rods (including masts and free standing masts)
- Meshed conductors (on building surface or elevated)
- Catenary wires
- Natural components

Meshed conductors used as air-terminations should not be confused with the mesh method. While the mesh method requires the use of surface mounted meshed conductors (a grid) to protect flat surfaces, the rolling sphere and protection angle method can also be used to determine protection provided by elevated meshed conductors to protect a variety of compound surfaces.

While the standard considers the three methods to be equivalent, recent research has questioned the true effectiveness of the mesh method. nVent recommends the rolling sphere method as the most effective. Rod air-terminations of height in the region of 0.5 m are preferable to shorter rods or conductors on the building surface. The rolling sphere method generally provides the most optimized design and the vertical air-terminal is far more effective at capturing lightning flashes than mesh conductors installed upon, or just above structure surface. Refer to **Section 10.1** for further information.

The radius of the rolling sphere, the mesh size and the angles used in the protection angle method are related to the class of the lightning protection system. Lightning protection class I, II, III & IV relate to protection level I, II, III, & IV respectively. For example if the risk assessment determines that a lightning protection system with lightning protection class II is required to reduce the risk to below the tolerable level, then the design of the lightning protection system will need to be in accordance with the requirements of lightning protection level II (or higher). The greater the level of lightning protection (LPL I being the greatest), the larger the resulting material requirement for the lightning protection system.

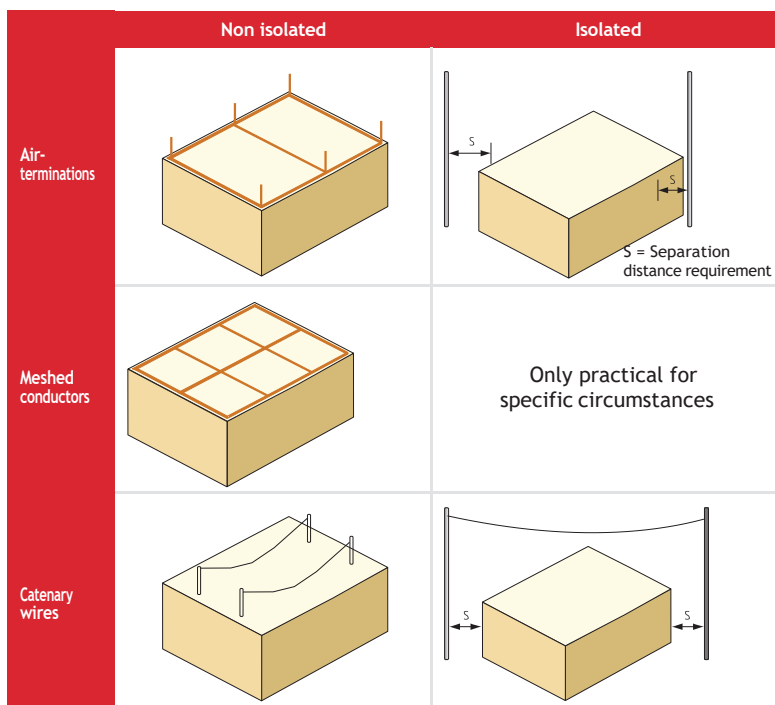


Figure 25. Air-Terminations.

The Class of LPS/LPL influences the:

- Rolling sphere radius, mesh size and protection angle
- Typical distances between down-conductors and between ring conductors
- Separation distances
- Minimum length of earth electrodes

9. Design methods

Air-termination	Protection method		
	Rolling sphere	Mesh method	Protection angle
Rod	✓✓✓		✓✓
Meshed conductors - (on structure surface)		✓(1)	
Meshed conductors - (elevated from structure)	✓✓		✓✓
Catenary wires	✓✓		✓✓

Note: ⁽¹⁾ Mesh method is appropriate for the evaluation of the protection of the bound flat surface. Rolling sphere and protection angle methods can be used to determine protection of adjacent areas.

Table 17. Suitability of air-termination methods and design methods.

Class of LPS (lightning protection level)	Rolling sphere radius (m)	Mesh size (m)	Protection angle
I	20	5 x 5	Refer Figure 25
II	30	10 x 10	
III	45	15 x 15	
IV	60	20 x 20	

Table 18. Maximum values for design methods.

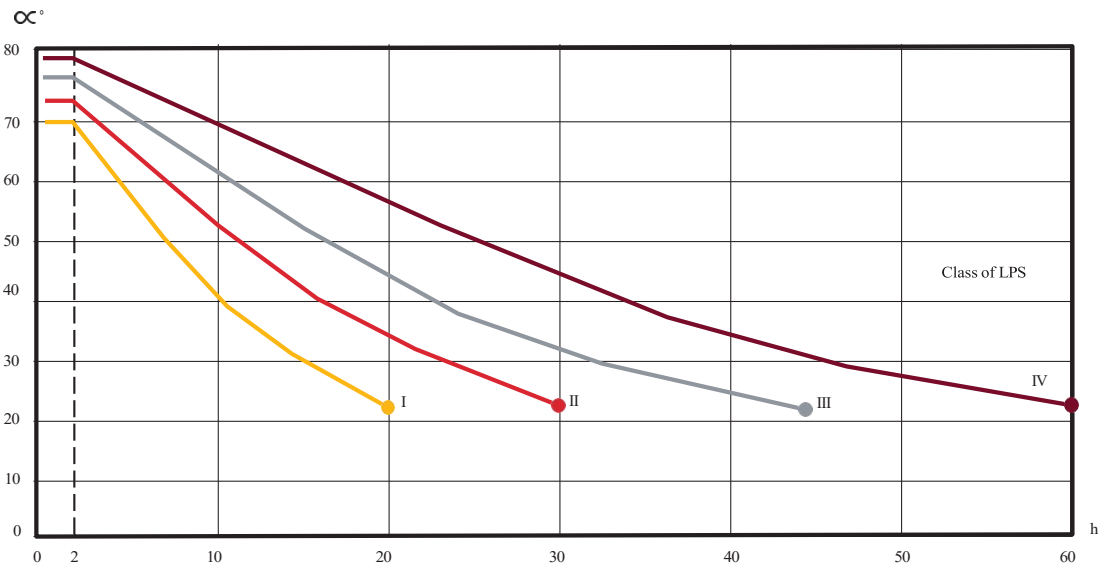


Figure 26. Protection angle graph.

Class of LPS	Lightning protection level (LPL)
I	I (highest)
II	II
III	III
IV	IV (lowest)

Table 19. Class of LPS and lightning protection level.

9. Design methods (continued)

9.1. ROLLING SPHERE

As discussed in **Section 2.3**, with the rolling sphere method, an imaginary sphere is rolled over the surface of the structure. Where the sphere touches the structure, this point is vulnerable to a lightning flash and air-termination(s) are required. The air-termination system is placed such that the sphere only touches the air-terminations, and not the structure.

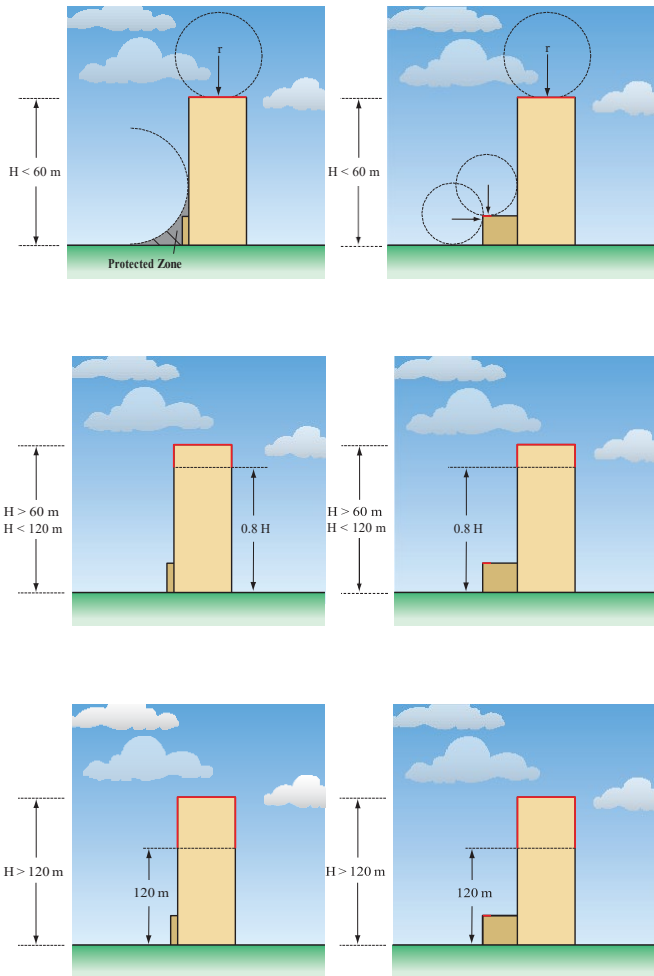


Figure 27. Rolling sphere protection method.

The simplicity of the rolling sphere method is that it can be applied in scale to a building model, or for simple buildings to sectional drawings. As detailed in **Section 10**, air-terminations may be rods, meshed conductors, catenary wires or natural components.

Note that for structures less than 60 m high the risk of flashes to the sides of the building is low, and therefore protection is not required for the vertical sides directly below protected areas (**Figure 27**). In the IEC standards, for buildings above 60 m, protection is required to the sides of the upper 20% of height, refer to **Section 16.1**.

9.1.1. CALCULATIONS FOR ROLLING SPHERE METHOD WITH ROD AIR-TERMINATIONS

When rods are to be used as the air-termination for the protection of plane surfaces, the following calculation (**Equation 2**) is useful:

$$d = 2\sqrt{2rh - h^2}$$

Equation 2

Where d = distance between two rods (m) r = radius of the rolling sphere (m) h = height of the rods (m)

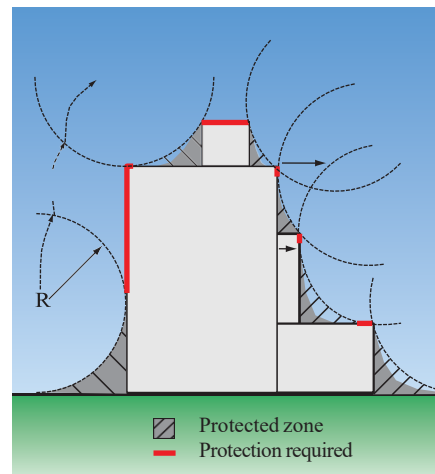


Figure 28. Rolling sphere protection method.

9. Design methods (continued)

Height of rod (m)	Distance between air-terminations (m)			
	LPL I r = 20 m	LPL II r = 30 m	LPL III r = 45 m	LPL IV r = 60 m
0.5	8.8 (6.2)	10.9 (7.7)	13.3 (9.4)	15.4 (10.9)
1	12.4 (8.8)	15.3 (10.8)	18.8 (13.3)	21.8 (15.4)
1.5	15.2 (10.7)	18.7 (13.2)	23.0 (16.2)	26.6 (18.8)
2	17.4 (12.3)	21.5 (15.2)	26.5 (18.7)	30.7 (21.7)

Note: Distances in brackets provide grid distances.

Table 20. Examples of rolling sphere protection distance.

When rods are to be used as the air-termination for protection of roof top items, the following calculation (**Equation 3**) of sphere penetration distance is useful:

$$p = r - \sqrt{r^2 - \left(\frac{d}{2}\right)^2}$$

Equation 3

where p = penetration distance (m)
 r = radius of the rolling sphere (m)
 d = distance between the two rods (m)

Distance between rods D (m)	Penetration distance (m)			
	LPL I $r = 20$ m	LPL II $r = 30$ m	LPL III $r = 45$ m	LPL IV $r = 60$ m
1	0.01	0.00	0.00	0.00
2	0.03	0.02	0.01	0.01
3	0.06	0.04	0.03	0.02
4	0.10	0.07	0.04	0.03
5	0.16	0.10	0.07	0.05
6	0.23	0.15	0.10	0.08
7 (5 x 5 m)	0.31	0.20	0.14	0.10
8	0.40	0.27	0.18	0.13
9	0.51	0.34	0.23	0.17
10	0.64	0.42	0.28	0.21
14 (10 x 10 m)	1.27	0.83	0.55	0.41
15	1.46	0.95	0.63	0.47
20	2.68	1.72	1.13	0.84
21 (15 x 15 m)	2.98	1.90	1.24	0.93
28 (20 x 20 m)	5.72	3.47	2.34	1.66
30	6.77	4.02	2.57	1.91

Note: Figures in brackets are the mesh size of the corresponding diagonal distance.

Table 21. Rolling sphere penetration distance.

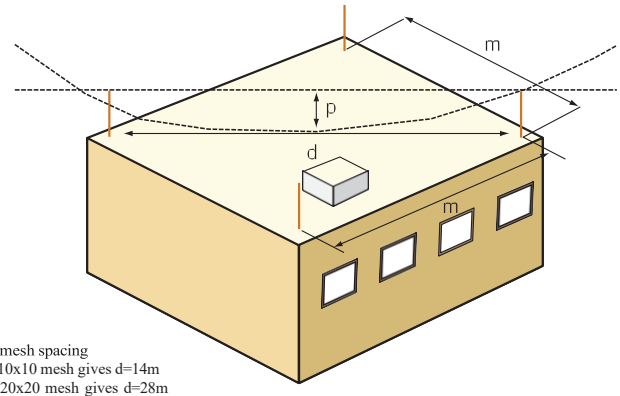
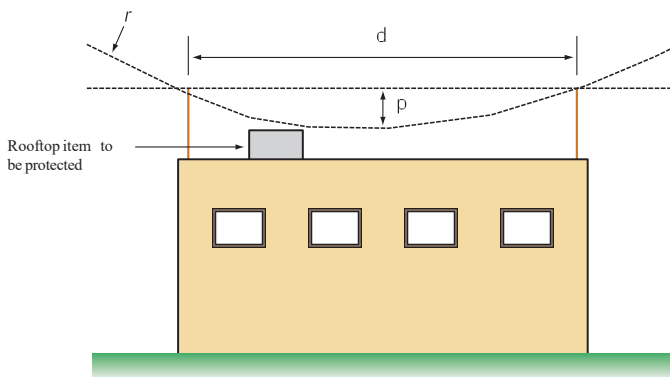


Figure 29. Penetration distance of rolling sphere.

9. Design methods (continued)

9.1.2. CALCULATIONS OF ROLLING SPHERE METHOD AND MESH/CATENARY CONDUCTORS

Where the rolling sphere method is to be used to evaluate the protection provided by mesh conductors or network of catenary wires, the preceding two calculations (**Equations 2 & 3**) can be used. The distance/height of the mesh/catenary replaces the rod distance/height. In **Figure 29** note that the distance for penetration or protection distance is the diagonal of the grid

(distance between points A & B).

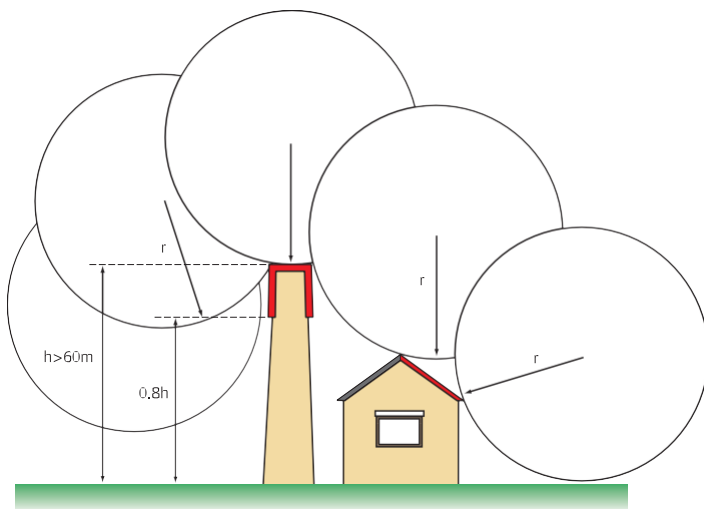


Figure 30. Example of rolling sphere method.

9.2. MESH METHOD

For protection of a plane (flat) surface, the mesh method is considered to protect the whole bound surface if meshed conductors are:

- Positioned on the edges (perimeter) of the surface
- The mesh size is in accordance with **Table 22**

LPL	Mesh Size
I	5 m x 5 m
II	10 m x 10 m
III	15 m x 15 m
IV	20 m x 20 m

Table 22. Mesh size for mesh method.

- No metallic structures protrude outside the volume (Refer to **Section 10.3** – consider air-terminals and RSM/PAM method to protect these)
- From each point, at least two separate paths exist to ground (i.e. no dead ends), and these paths follow the most direct routes

Natural components may be used for part of the mesh grid, or even the entire grid. The mesh method is recommended for flat roof surfaces. It is also recommended for the protection of the sides of tall buildings against flashes to the side (refer to **Section 16.1**).

9. Design methods (continued)

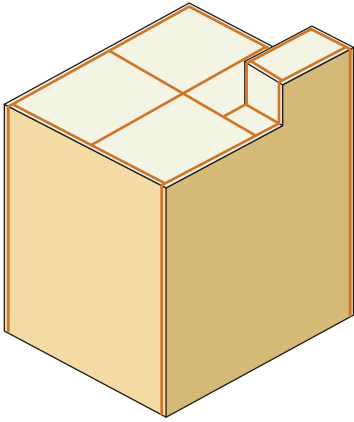


Figure 31. Protection via mesh method.

The mesh method should not be used on curved surfaces, but can be used on non-horizontal plane surfaces and compound surfaces. For example on the vertical sides of tall buildings for protection against flashes to the side, or on compound surfaces such as industrial roofs. For compound surfaces, conductors should be placed on the roof ridge lines if the slope exceeds 1/10.

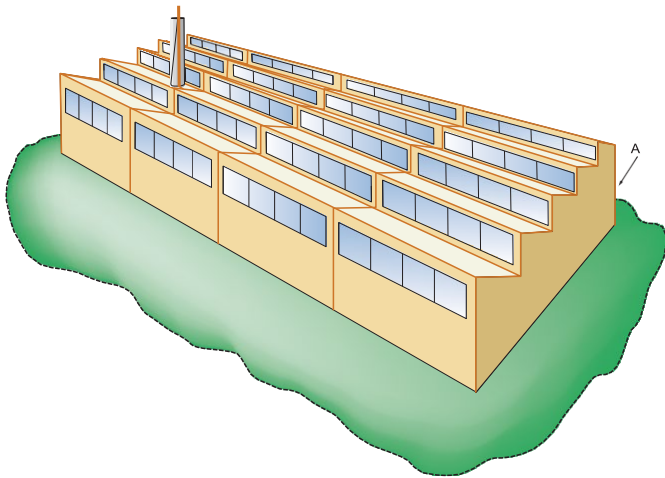


Figure 32. Mesh method for compound shapes.

The protective area provided by the mesh method is the area bounded by the mesh. The protection to areas adjacent to the mesh (e.g. building sides and lower structural points) is determined by the protection angle method or rolling sphere method (refer to **Figure 33**).

The protection provided by meshed conductors not placed in full accordance with the mesh method, e.g., those raised above the building surface, should be determined with an alternative design method, i.e., PAM or RSM, applied to the individual conductors. If the RSM is used, **Table 21** provides a simple rule of thumb for determining what minimum distance above the building surface the mesh conductors would be required to be raised in order to conform to the rolling sphere method. It can be seen that this distance is 0.31, 0.83, 1.24 and 1.66 m for mesh method grids spaced to requirements of LPL I, II, III and IV respectively.

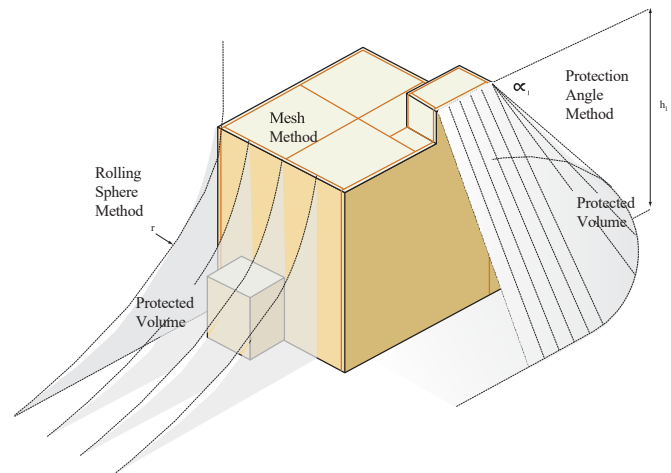


Figure 33. Volume protected by meshed conductors according to PAM and RSM method.

9. Design Methods (continued)

9.3. PROTECTION ANGLE METHOD

Air-terminations (rods/masts and catenary wires) are located so the volume defined by the protection angle (refer to **Figure 34**) covers the structure to be protected. The height of the air-termination is measured from the top of the air-termination to the surface to be protected. The protection angle method is limited in application to heights that are equal to or less than the corresponding rolling sphere radius.

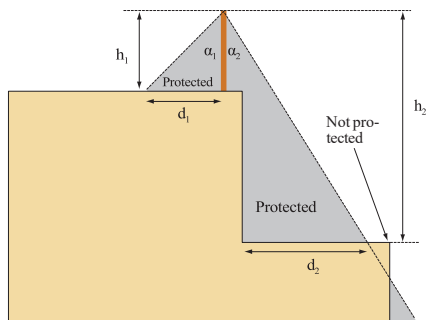


Figure 34. Protection angle method.

Where the protection angle method alone is employed, multiple rods are generally required for most structures. However the protection angle method is most commonly used to supplement the mesh method, providing protection to items protruding from the plane surface.

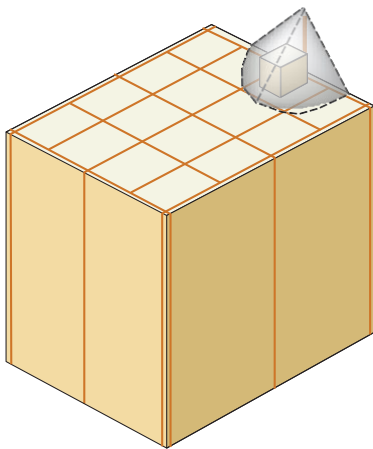


Figure 35. Combination protection.

The protection angle method can be used on inclined surfaces, where the height of the rod is the vertical height, but the protection angle is referenced from a perpendicular line from the surface to the tip of the rod.

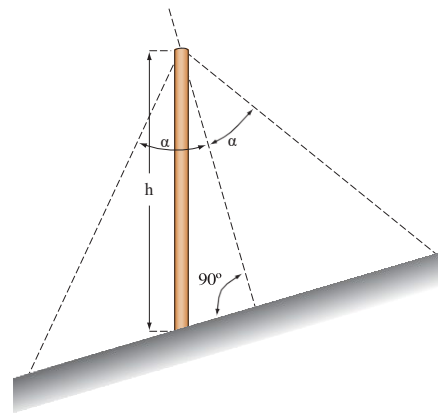


Figure 36. Protection angle method applied to inclined surface.

9. Design Methods (continued)

Height h of air-termination (m)	Distance d (m) and protection angle (rounded down to nearest degree)							
	LPL I		LPL II		LPL III		LPL IV	
	Distance	Angle	Distance	Angle	Distance	Angle	Distance	Angle
1	2.75	70	3.27	73	4.01	76	4.70	78
2	5.49	70	6.54	73	8.02	76	9.41	78
3	7.07	67	8.71	71	10.46	74	12.99	77
4	7.52	62	9.42	67	12.31	72	13.95	74
5	8.32	59	10.25	64	14.52	71	16.35	73
6	8.57	55	10.82	61	14.14	67	17.43	71
7	9.29	53	11.65	59	15.72	66	18.24	69
8	9.53	50	12.32	57	16.40	64	18.85	67
9	9.65	47	12.85	55	16.93	62	20.21	66
10	10.00	45	13.27	53	17.32	60	20.50	64
11	9.90	42	14.08	52	19.05	60	19.84	61
12	10.07	40	14.30	50	19.20	58	20.78	60
13	10.16	38	14.44	48	19.27	56	21.64	59
14	9.80	35	14.50	46	19.27	54	22.40	58
15	9.74	33	15.00	45	19.91	53	23.10	57
16	9.61	31	14.92	43	20.48	52	22.85	55
17	9.04	28	15.31	42	20.99	51	23.40	54
18	8.78	26	15.65	41	21.45	50	23.89	53
19	8.86	25	15.94	40	21.86	49	25.21	53
20	7.68	21	15.07	37	21.45	47	25.60	52
21			14.70	35	21.75	46	25.93	51
22			14.84	34	22.00	45	26.22	50
23			14.94	33	22.21	44	27.41	50
24			14.42	31	22.38	43	26.65	48
25			14.43	30	22.51	42	26.81	47
26			13.82	28	21.82	40	27.88	47
27			13.17	26	22.66	40	27.96	46
28			13.06	25	21.88	38	28.00	45
29			12.91	24	21.85	37	28.00	44
30			12.73	23	21.80	36	28.97	44
31					21.71	35	28.91	43
32					21.58	34	28.81	42
33					21.43	33	28.69	41
34					21.25	32	28.53	40
35					21.03	31	28.34	39
36					20.78	30	29.15	39
37					20.51	29	28.91	38
38					20.20	28	28.64	37
39					19.87	27	29.39	37
40					19.51	26	29.06	36
41					19.12	25	29.79	36
42					18.70	24	30.51	36
43					18.25	23	30.11	35
44					18.68	23	28.57	33
45					18.18	22	29.22	33
46							28.74	32
47							28.24	31
48							27.71	30
49							28.29	30
50							28.87	30
51							28.27	29
52							28.82	29
53							29.38	29
54							28.71	28
55							28.02	27
56							27.31	26
57							26.58	25
58							25.82	24
59							25.04	23
60							25.47	23

Table 23. Height versus horizontal distance using protection angle method.

9. Design methods (continued)

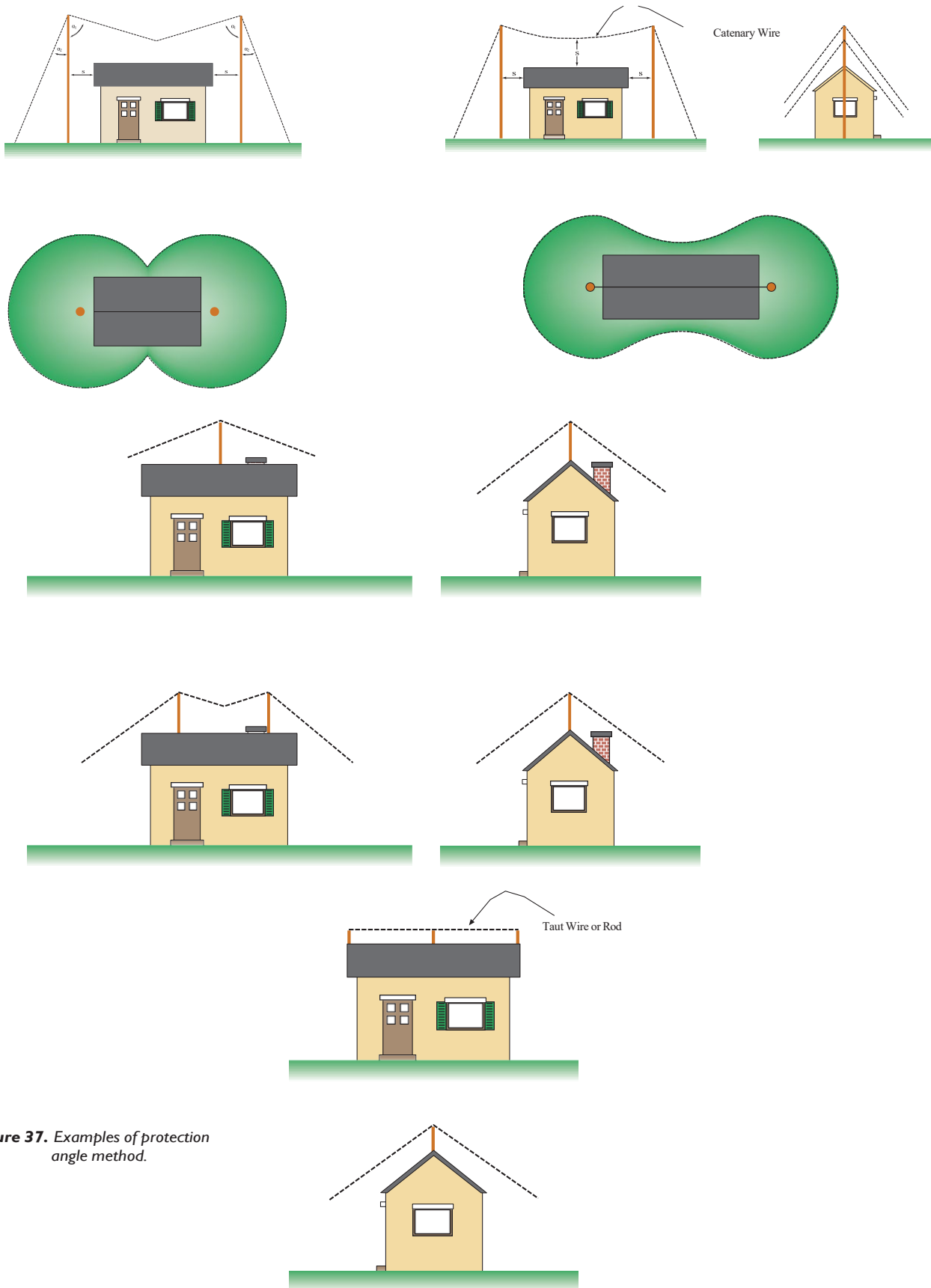


Figure 37. Examples of protection angle method.

9. Design methods (continued)

9.3.1. BACKGROUND OF THE PROTECTION ANGLE METHOD

While the protection angle method appears to be similar to the historic and simple cone of protection method, the protection angle method is actually a derivative of the rolling sphere method. The angles for the protection angle method are obtained from a rolling sphere analysis as shown in **Figure 38**. This is why the protection angle method is limited to the maximum height of the equivalent rolling sphere. Consider a 50 m structure with rod air-termination. As a 45 m rolling sphere (LPL III) would touch the side of the structure, protection to objects at the ground level can not be protected using protection angle with LPL III. Considering LPL IV, a 60 m rolling sphere would not touch the side of the structure, thus protection angle LPL IV can be used with the rod air-termination to determine what objects at the ground level would be protected.

The virtue of the protection angle method is its simplicity in application, but its drawback is that it is a further simplification of the rolling sphere method, hence may not be as reliable or efficient.

The knowledge that the protection angle method is derived from the rolling sphere method helps to understand a common question about its implementation. With reference to **Figure 34**, it may not be apparent why α_2 is less than α_1 . If a second air-terminal is installed to the left of the existing air-terminal, then α_1 and α_2 for the second terminal would be equal. The reason that h_2 is used for α_2 is an attempt to duplicate the protection indicated by the rolling sphere method.

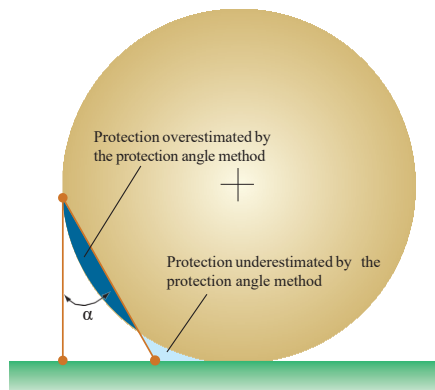


Figure 38. Origin of protection angle.

10. Air-terminations

10. AIR-TERMINATIONS

Air-terminations are those items specifically placed to capture the lightning flashes. Permitted air-terminations are:

- Rods (including masts and free standing masts)
- Meshed conductors (on building surface or elevated)
- Catenary wires
- Natural components

Air-terminations are placed in accordance with the selected design method to provide protection to the structure. Additionally:

- Air-terminations should be interconnected at each structure level
- Air-terminations should be connected to down-conductors as per **Section 11**
- Mesh and air-termination interconnections should be provided with expansion joints (refer to **Section 10.5**)
- Rod air-terminations should be located or designed (suitable height or tip shape) to avoid the creation of an impalement hazard



Figure 40. Typical air-terminations.

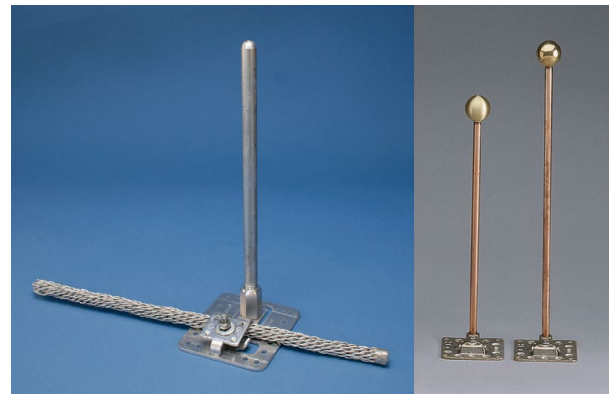


Figure 41. Rod designs to reduce risk of impalement.

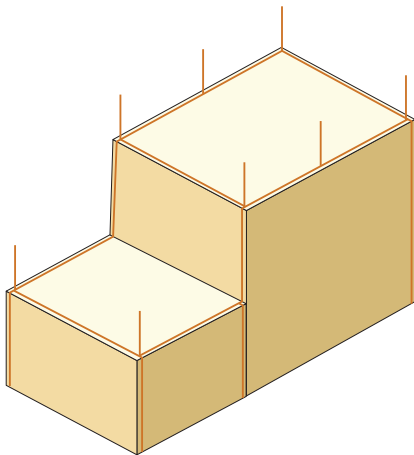


Figure 39. Air-terminal interconnections.

In placing conductors upon the roof, several additional considerations should be taken:

- Install as close as practical to roof edges
- Secure per requirements provided in **Table 26**
- Select materials to reduce risk of corrosion
- Do not introduce trip hazards upon roof surface
- Do not locate in areas where water may pool (e.g. gutters)
- Avoid penetrations into roof for fixing of conductors

10. Air-terminations

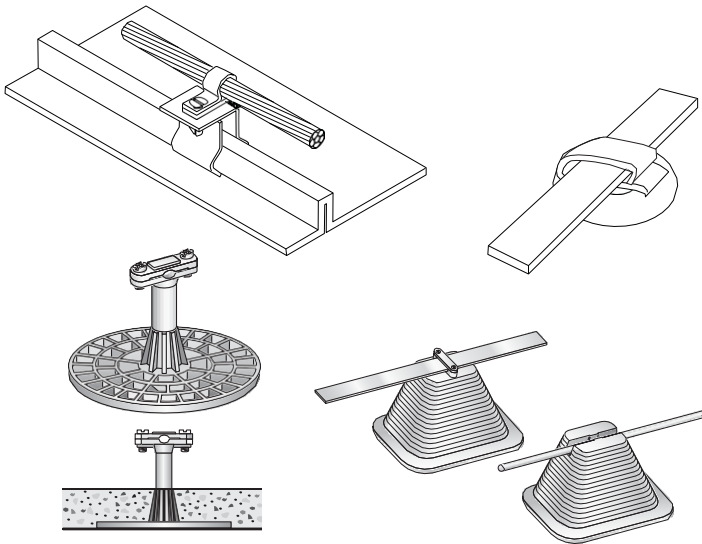


Figure 42. Adhesive bases, mounting blocks and standing seams avoid need for penetrative mounting of conductor fixings.

10.1. RECOMMENDATION ON POSITIONING

IEC 62305-3 provides general statements on positioning of air-terminations, such as on corners, exposed points and edges. However, no specific dimensions or tolerances are given. Often the question occurs from the installers, “how close is close enough?”. The strict answer is that the positioning of air-terminations should be compliant with the design method used (i.e. rolling sphere, protection angle or mesh method). Therefore a good design will document exact requirements to the installer or add a safety margin to design to cover normal variances. For example, air-terminals (rods) may be required on a parapet edge and a good design will allow sufficient height so that protection is provided regardless of whether the rods are installed on top of the parapet, or on the inside or outside edge.

While the IEC standards allow any height of air-terminal (rod) to be used, research shows that for effective protection, both the minimum height and the relationship of the height of the air-termination to distance from the structure edge is critical. For air-terminals of less than 0.5 m height, these need to be less than half their height from the edge to be most effective. It is recommended that a minimum height of 0.25 m be selected (0.5 m preferred), and placed as close as practical to any edge being protected (at least within $0.5 \times$ rod height).

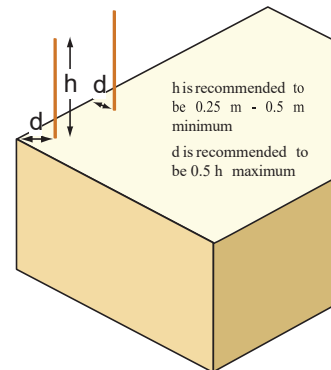


Figure 43. Recommended distances for placement.

This research does not bode well for horizontal conductors placed on the building via the mesh or other design methods, as the height of the conductor is the conductor thickness, typically 2 to 8 mm. The above research concludes that the conductor would need to be installed 1 to 4 mm from the structure edge. Generally, this is impossible due to the need to install clips to fasten the conductor. As these are often screwed in place, they can not be installed close to the edge.

In accordance with the design requirements of the rolling sphere method, any horizontal conductor on a building edge (and intended to be part of the air-termination network) would need to be virtually on the exact edge to stop the rolling sphere from touching the edge of the structure. The IEC standards do not give any assistance or recommendations on this issue. BS 6651-1991 infers that 0.1 m maximum distance is acceptable, yet this appears to be unsubstantiated.

Due to performance concerns, nVent would not recommend the use of the mesh method where horizontal conductors (for use as air-terminations) are installed directly onto the surface to be protected. The addition of vertical air-terminations (rods) improves the performance of the system considerably. For non mesh method designs, raising any horizontal air terminations at least 0.25 m above the surface improves performance. If the building edge uses a coping (metallic covering), then provided that the requirements for natural air-terminations are met, the coping eliminates the conductor placement concern. In many cases, at the design stage of the building, the use of coping, installation of metallic hand rails or careful selection of building materials and other structural items can significantly improve performance and reduce the visual impact of the lightning protection system.

If the horizontal conductor is not part of the air-termination network (i.e. is part of the bonding network joining air-terminals), then placement is not as critical provided the other air-terminations provide protection to the desired level.

10. Air-terminations (continued)

10.2. MASTS AND ANTENNAS

Masts and flag poles, etc, on the structure can be used as part of the air-termination system where they meet the requirements of natural components and do not contain electrical circuits. The masts should be bonded into the LPS system.

Antennas (communication and TV aerials, etc) and masts with electrical equipment (e.g. obstruction lighting) should be protected by an air-termination system, preferably an isolated system where the antenna and its mast does not conduct lightning currents.

For simple applications such as domestic roof top TV antennas it is permissible to simply bond the mast to the air-termination system, but damage to antenna/mast and cabling can be expected. Class I surge protection must be installed.

If the antenna is exposed to lightning flashes, then surge protection (Class I) must be installed. If the antenna is protected by an air-termination, then surge protection (Class II) should be installed. The preferred location for the SPD is as close as possible to the entry point of the cable into the structure, and where possible the cable should enter into the building near to, and be connected to an equipotential bonding bar. Screened cables should have the screen bonded to the antenna/air-termination and the equipotential bonding bar.

The ERICO isolated down-conductor system provides an air-terminal and isolated down-conductor that can be mounted directly on the mast/antenna structure to reduce the risk of direct or partial lightning currents. The isolated down-conductor has a special construction that allows it to be mounted directly on the mast, but provides the equivalent separation distance of 1000 mm of air. Refer to **Section 13** for further information.

10.3. PROTECTION OF OTHER ITEMS PROTRUDING ABOVE THE ROOF

The design of the lightning protection system should be such that air-terminations are positioned to provide protection against lightning flashes to the roof and all items located upon it (vents, skylights, air-handling units, pipes, etc). However, in some cases, protection is not required for smaller or non-conductive items. **Table 24** summarizes the requirements for determining if air-termination protection is required.

Note that the bonding requirements for these items requires separate consideration, refer to **Section 10.4**.

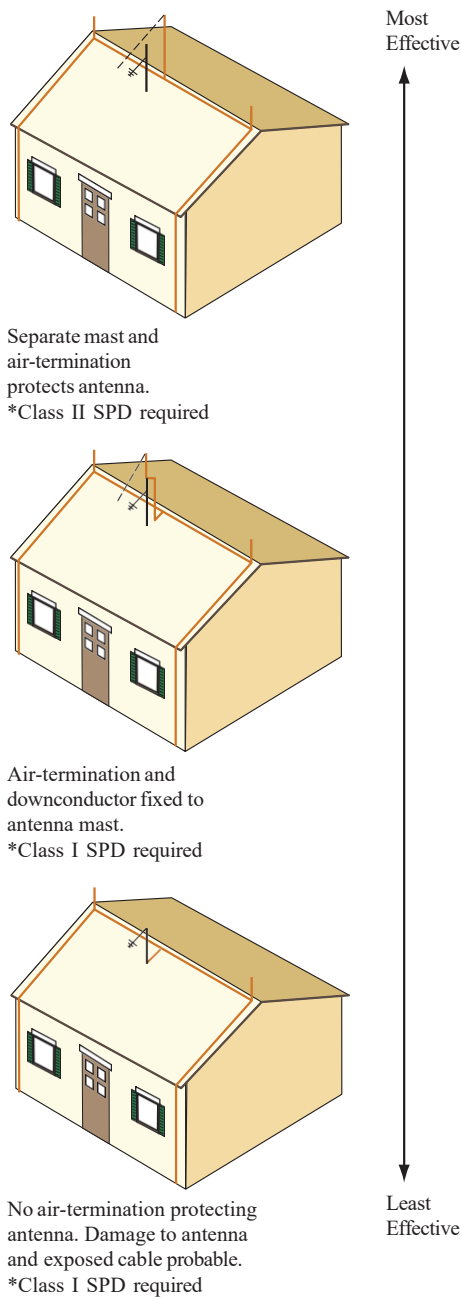


Figure 44. Protection of antenna.

Roof fixtures do not require protection if these dimensions are not exceeded:

Metal Roof Fixtures	Height above the roof level:	0.3 m
	The total area of the superstructure:	1.0 m ²
	The length of the superstructure:	2.0 m
Non-conductive Roof Fixtures	Protrusion above the surface formed by the air termination system:	0.5 m

Table 24. Roof fixtures not requiring protection.

10. Air-terminations (continued)

Conductive connections into the structure may be electrical circuits or non-electrical pipes such as metal pipes for water or gas, or air services. Items that have conductive connections into the structure interior require air-termination protection. Otherwise, considerable currents can be conducted into the structure interior.

IEC 62305-1 **Section 8.3.2** requires internal systems to be located inside a LPZ 1 or higher. LPZ 1 are zones protected against direct flashes and only exposed to limited lightning or induced currents. To meet this requirement, conductive connections (e.g. water or gas pipes, electrical power or electronic control cables) are required to be bonded to the LPS. For the bonding of electrical/electronic circuits, surge protective devices (SPDs) are required.

In some cases, it may be possible to replace conductive connections with insulated (non conductive) connections (twice the length of the separation distance requirement), thus overcoming these requirements. For example a small pressurized air reservoir (< 0.3 m high, < 1 m², less than 2 m width or length and meeting natural air-termination thickness requirements), but with metallic pipes entering into the facility, requires air-terminals and bonding of pipes. However, if the connecting pipes were replaced with non conductive pipes, then air-terminals and bonding would not be required.

As an example of the application of **Figure 45**, a plastic vent such as those used for plumbing would not require protection if protruding less than 0.5 m above the protection zone. If greater than 0.5 m above the protection zone, then air-terminal protection would be required (refer to **Figure 45**).

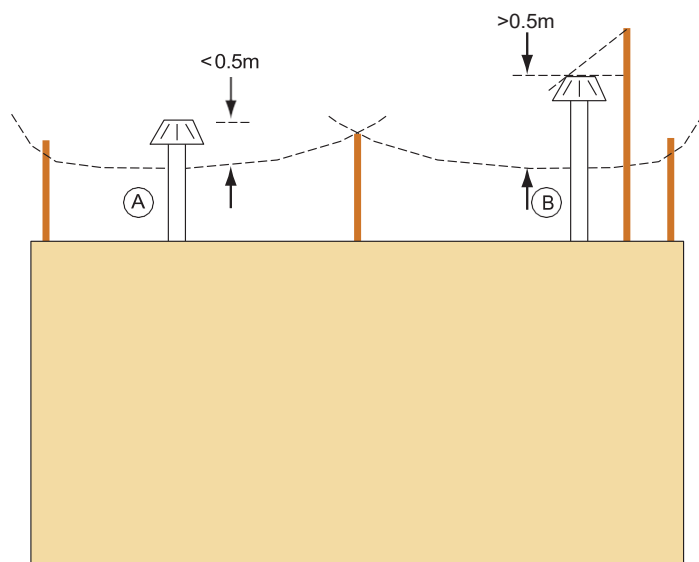


Figure 45. Example of protection requirements for non conductive roof fixture.

All items on the roof that contain electronic or electrical equipment require protection via air-terminations (refer to **Figure 46**). Additionally for electrical and electronic items, protection is also required if wall mounted in a location where a lightning flash may occur (i.e. in a location touched by rolling sphere method). Surge protective devices must be installed on the circuits to limit current entering into the internal environment.

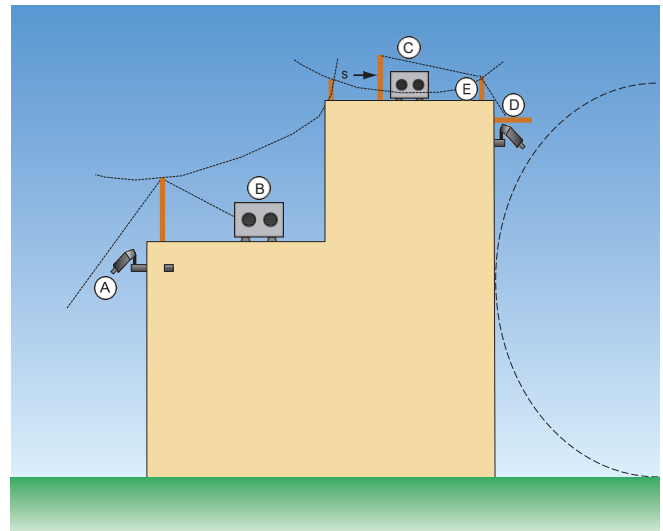


Figure 46. Air-termination protection required to wall mounted electronic / electrical equipment.

10. Air-terminations (continued)

While most chimneys are tall enough to require protection, in the case of non-conductive chimneys, or similar vents, protection is still recommended, as soot deposits can effectively make these items conductive.

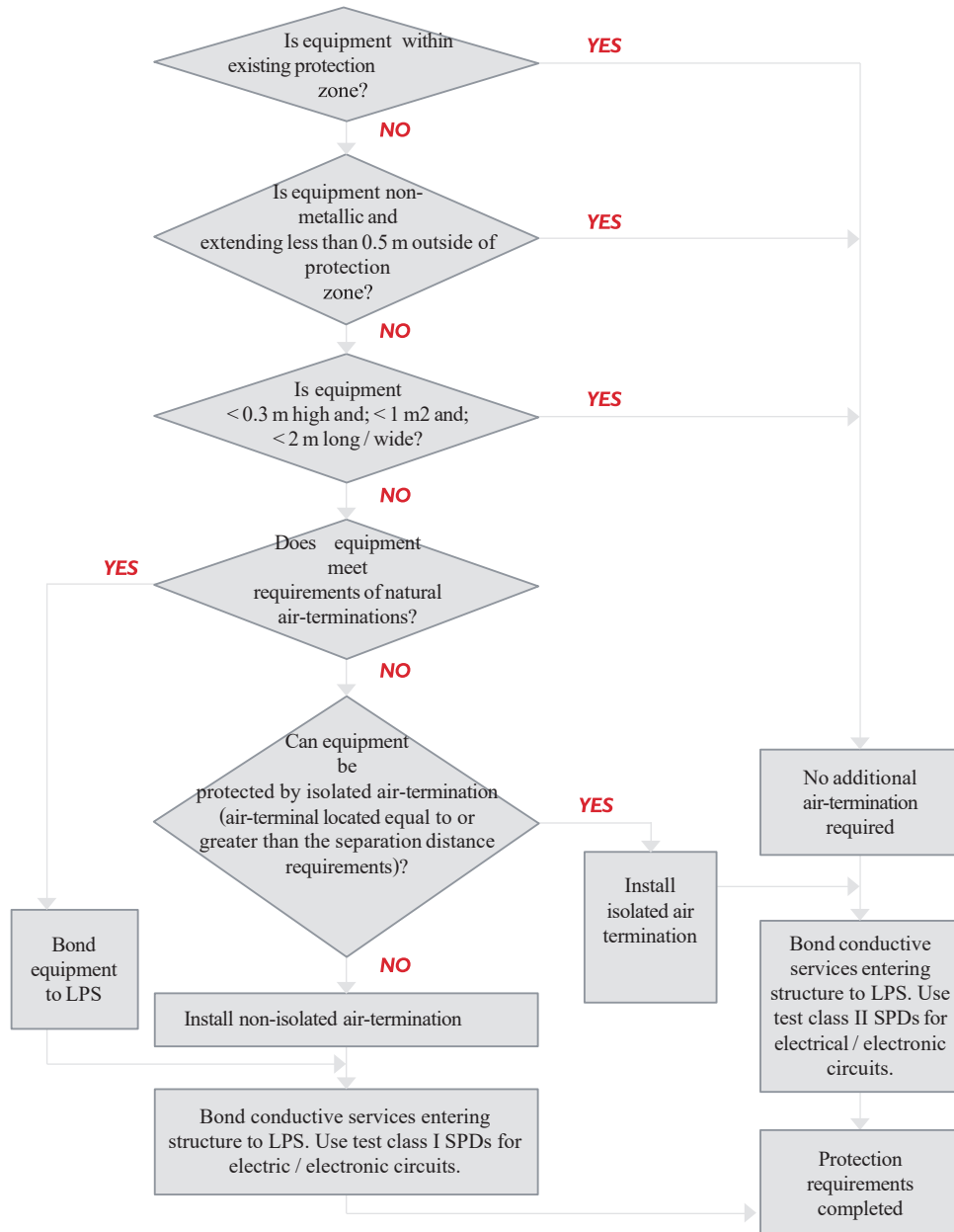


Figure 47. Flowchart showing requirements for roof top items.

10. Air-terminations (continued)

10.4. BONDING OF ROOF TOP FIXTURES

Separation distance requirements between the air-terminations and all conductive roof fixtures (including conductive flush mount fixtures) should be evaluated to determine if bonding of the item is required. If the separation distance can not be maintained between the conductive fixture and the LPS system (air-termination or down-conductor, etc), then a dedicated bond between the two must be made.

Separation distance and other bonding requirements are detailed in **Section 12**. This section shows how separation distance requirements must be considered for the air separation, the surface separation and in some cases the separation through intermediate materials.

To eliminate the need to bond, it may be possible to select air-termination location and height so the fixture is protected by the air-termination, but positioned far enough distance away so that bonding is not required.

10.5. EXPANSION JOINTS AND ROOF PENETRATIONS

Design should also allow for expansion and contraction of mesh and air-terminal interconnection conductors due to temperature variation. An annual temperature variation of $-10\text{ }^{\circ}\text{C}$ to $+35\text{ }^{\circ}\text{C}$ may cause the following conductor movement:

- Aluminum 1.0 mm (per linear meter)
- Copper 0.75 mm (per linear meter)

Over a long conductor run this movement may cause considerable damage if expansion joints are not installed – adhesive base, conductor clips or roofing material may be stressed or damaged. As a guide, expansion connections should be installed approximately every 40 m, refer to **Figure 49** for example. Expansion joints are not required with smooth weave conductors.

For copper conductors, nVent recommends ERICO copper bonding strap 556820 “MBJ-50-100-10” (100 mm long x 28 mm x 2.5 mm flexible tinned copper strap with 10.5 mm connection holes) for use as an expansion joint. Four are required for crossover expansion connections.

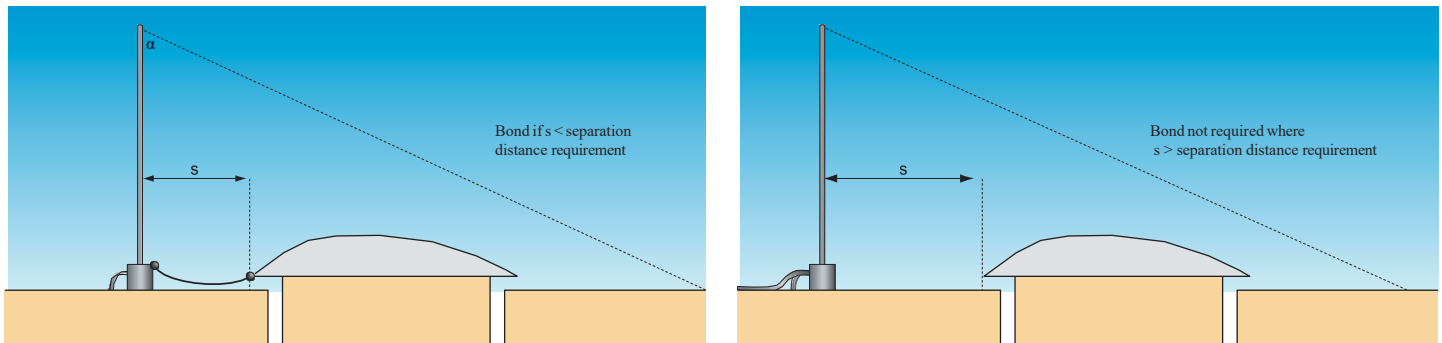


Figure 48. Location of air-terminal and bonding requirement for conductive items.

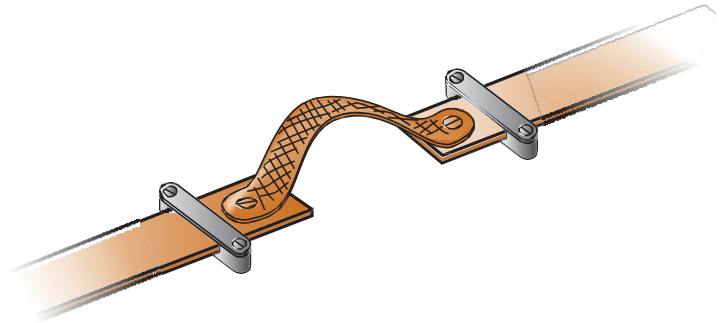


Figure 49. Conductor expansion joints.

11. Down-conductors

11. DOWN-CONDUCTORS

Down-conductors provide the interconnection of the air-terminations to the earthing termination. It is possible that the same conductor type may be used for air-terminations (e.g. mesh method), down-conductor and earthing electrodes (counterpoise ring).



Figure 50. Typical down-conductor test joints.



Figure 51. Typical down-conductor connectors.

Materials and sizes of the down-conductor should conform to the requirements of **Table 26**. Natural elements of the structure are permitted, refer to **Section 8**.

The down-conductor system should provide multiple parallel paths for the discharge of energy to ground. This lowers the current density, thus reducing the risk of side flashing, and reducing electromagnetic radiation effects of the impulse current at points inside the structure. On taller structures, horizontal equipotential bonding rings are also used to improve current sharing between down-conductors (refer to **Table 26**).

The number of down-conductors has a direct effect upon the bonding requirements. Nearby metallic items and internal conductive items may need bonding in accordance with the separation distance requirements. In some cases it may be practical to increase the number of down-conductors to reduce the separation requirements.

In general, a down-conductor system should:

- Provide multiple paths for lightning current
- Be as short and straight as practical
- Be spaced and use equipotential bonding rings as per **Table 26**
- Be a direct continuation of the air-termination system
- Not be installed in gutters or down-spouts (even if PVC covered)
- Connect via a test joint to the earth termination network
- Be fitted with external protection to reduce exposure to accidental damage or vandalism
- Be fitted with 3mm cross-linked polyethylene insulation where there is risk of danger due to touch potential

Refer to **Section 11.1.1** and **11.1.2** for specific requirements.

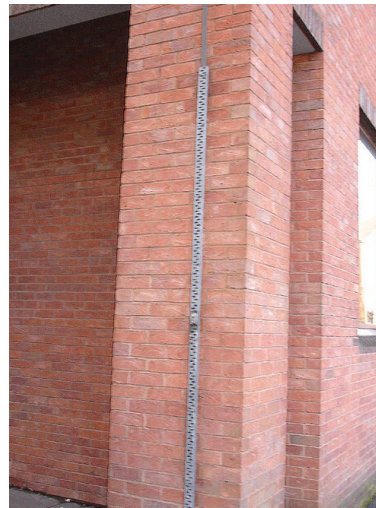


Figure 53. External protection should be provided against damage and vandalism.

Class of LPS (LPL)	Typical distance (m)
I	10
II	10
III	15
IV	20

Table 25. Typical spacing of down-conductors and equipotential bonding rings.

11. Down-conductors

If down-conductors can not be spaced symmetrically, a variation of $\pm 20\%$ of the distance requirements of **Table 13** is permitted, provided the mean spacing of down-conductors conforms with the values shown.

Table 13 provides the requirements for spacing of the equipotential bonding ring. It is recommended that the first equipotential ring (lateral connection) be installed at or near ground level, then at the height intervals given. Where earthing electrodes are installed per type B (ring electrodes, refer to **Section 14.3**), the ring electrode can be considered to be the first equipotential bonding ring.

11.1. DOWN-CONDUCTORS FOR ISOLATED AND NON-ISOLATED LPS

11.1.1. DOWN-CONDUCTORS FOR NON-ISOLATED LPS

The general requirements for down-conductors on non-isolated LPS are:

- At least two down-conductors should be used
- Down-conductors should be equally distributed around the perimeter of the structure (within practical and aesthetic reasons)
- Down-conductor should be located at exposed (external) corners of the structure where possible (within 300 mm)
- Attempt to locate down-conductors (using separation distance requirements) away from windows, doors, exits or where people may congregate. To reduce touch and step potential hazards, select routes where any external earth electrode systems would need to be located in a similar location



Figure 54. Example of poorly located a down-conductor.

11.1.2. DOWN-CONDUCTORS FOR ISOLATED LPS

The general requirements for down-conductors in an isolated LPS are:

- For rod air-terminations, one down-conductor is required per mast. If the mast is metallic or interconnected reinforcing steel, then no additional down-conductor is required
- For catenary air-terminations (one or more wires), at least one down-conductor is required per support

11.2. DOWN-CONDUCTOR ROUTING

Down-conductors should, where possible, be installed straight and vertical, but generally following the profile of the building. Loops and overhangs should be avoided.

Where loops can not be avoided, the distance s , across the gap shall be greater than the separation distance for length l . If this is not possible then the down-conductor should be routed directly through the structure.

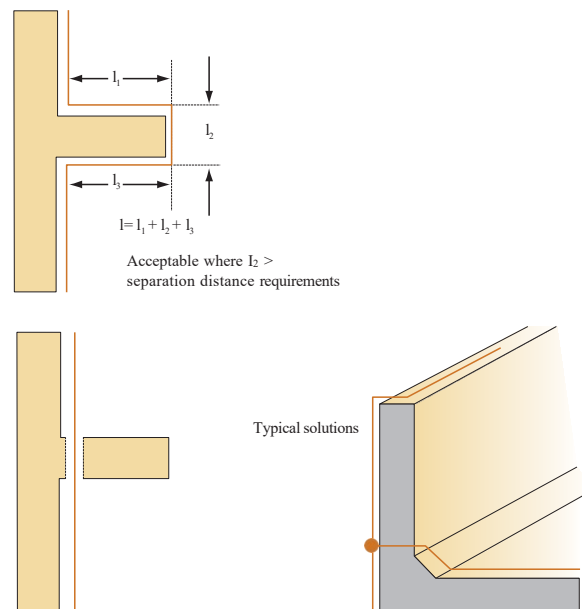


Figure 55. Down-conductor loops.

11. Down-conductors (continued)

Structures with overhangs where the down-conductor must be routed along the overhang can create a hazardous risk of flashover. This is of particular concern where persons can be present. This situation should be avoided if the required separation distance (to a person with outstretched arms (2.5 m) can not be maintained. Additional down-conductors may be required to meet the separation requirements, or locate down-conductors in air space of non-metallic, non-combustible internal duct (not containing electrical cables).

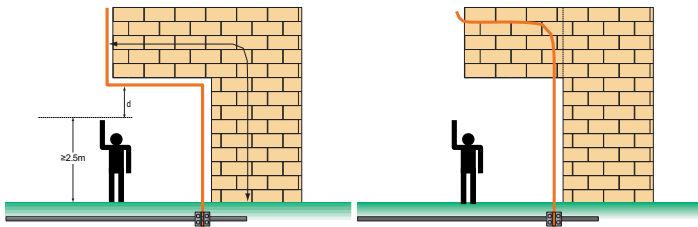


Figure 56. Overhangs.

In a non-isolated system, the down-conductor can be installed on non-combustible walls, or within (non-combustible) walls.

For combustible walls, the down-conductor may be placed on the wall provided the temperature rise of the conductor under lightning conditions does not create a dangerous condition (Refer to IEC 62305-1 Annex D.4, where for LPL I, 50 mm² copper rise is 22 °C and 50 mm² Aluminum is 54 °C). Alternatively, the down-conductor may be located using standoff brackets so that at least 100 mm distance is maintained, or conductor size increased to 100 mm² cross sectional area.

Care is required in routing conductors within walls, or the wall cavity:

- Open cavities are preferred as the thermal expansion of the down-conductor under lightning conditions can cause cracking of plaster covered conductors
- Bare aluminum conductors should not be placed in direct contact with plaster, mortar or concrete, etc
- Discoloration of plaster should be considered
- In areas with limited volume or strength, the electromechanical shock wave may cause damage

In large flat structures where more than 4 down-conductors are required on one of the perimeter surfaces (e.g. industrial buildings, exhibition halls, etc), then extra internal down-conductors should be installed approximately every 40 m. Roof support columns should be utilized.

11.3. FIXING OF DOWN-CONDUCTORS

Down-conductors (including conductors used for air-terminations) can be fixed using conductive or non-conductive fixtures.

Conductors should not be fixed directly to the surface if the material is combustible.

Arrangement	Fixing centers tape and stranded conductors mm	Fixing centers round solid conductors mm
Horizontal conductors on horizontal surfaces	500	1000
Horizontal conductors on vertical surfaces	500	1000
Vertical conductors from the ground to 20 m	1000	1000
Vertical conductors from 20 m and thereafter	500	1000

Table 26. Suggested conductor fixing centers.

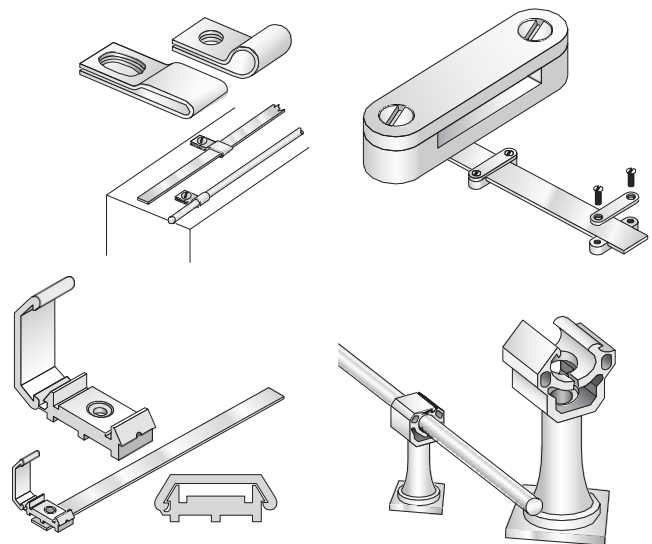


Figure 57. Typical down-conductor fixings.

12. BONDING AND SEPARATION DISTANCES

Bonding or isolation by adherence to separation distance requirements is required to protect against dangerous sparking between the LPS and structure/internal systems. The main areas to be addressed are:

- External services entering into the structure (e.g. telephone, power lines, water, gas, etc)
- External metallic items entering the structure (e.g. cable ducts, pipe work, etc)
- Metallic items on or in the structure (e.g. hand rails, elevator rails, pipes, ventilation ducts, etc)
- Internal electrical and electronic circuits and systems

The dangerous sparking can be controlled by:

- Equipotential bonding of the item to the LPS:
 - via direct connection, or
 - by utilizing a surge protective device (SPD) for bonding of electrical systems and services
- Insulation of the item from the LPS (by means of separation distance across a given medium such as air or concrete).

By design, an isolated LPS controls dangerous sparking by adherence to separation distance requirements. Therefore, an isolated LPS only requires bonding to the structure at ground level. Non-isolated LPS's require bonding to the structure at ground level, and at locations where separation distance requirements can not be maintained.

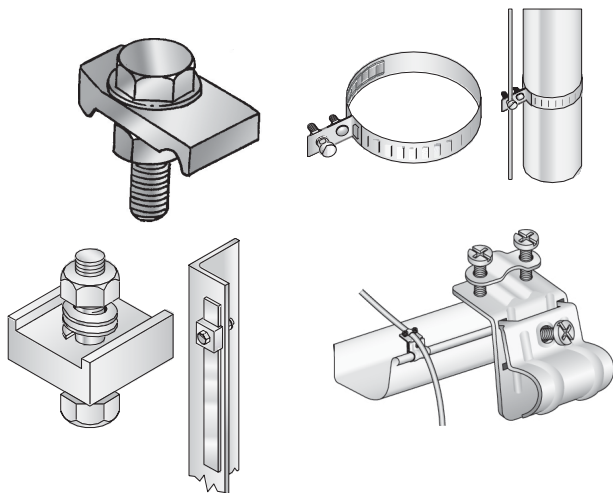


Figure 58. Typical bonding devices.

Note that other standards/codes such as local electrical codes require bonding of services and other metallic items. The requirements of these codes must also be followed.

12.1. BONDING OF SERVICES AND EXTERNAL CONDUCTIVE PARTS

At basement or ground level, a bonding bar is required to be installed and connected to the LPS earth electrode system. The bonding bar should be located as close as possible to, and connect to, all external metallic services entering the facility (gas pipes, water, power, telephone, etc). In large facilities, several interconnected bonding bars may be needed. Interconnection should be via a dedicated internal ring (or partial ring), or via the internal reinforcing of the concrete construction.

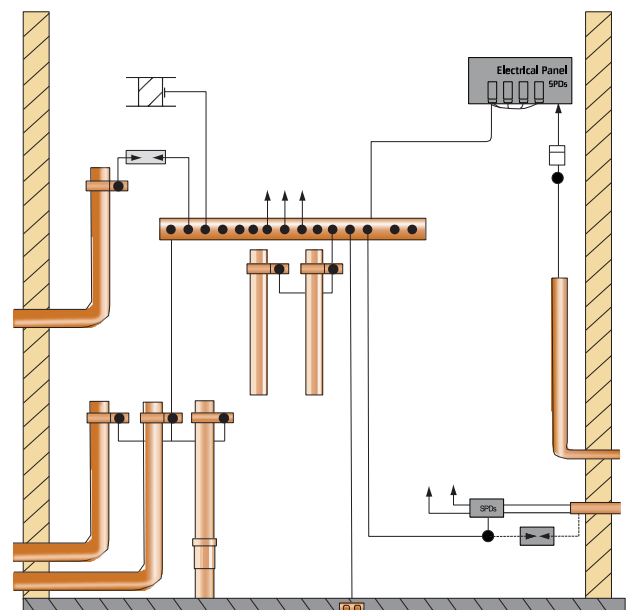


Figure 59. Bonding of services.

It is good practice to bring all services into the structure in close proximity to each other to simplify the bonding requirements, and to minimize voltage differentials between each service. This is especially important for the protection of sensitive equipment such as computers and communication equipment which may interconnect to both services.

Services and metallic items entering the facility may include:

- Telephone and telecommunication lines
- Cable TV circuits
- Antenna feeders
- Power lines
- Pipe work (water, air, gas, etc)
- Metal ducts

Where permitted, these items should be bonded directly to the bonding bar. In the cases of electrical, electronic and tele/data communications services, bonding should be via

surge protective devices.

12 Bonding and separation distances (continued)

Material	Cross section (mm ²)	
	Between bonding bars and to earth electrode	To metallic items
Copper	14	5
Aluminum	22	8
Steel	50	16

Table 27. Minimum bonding conductor dimensions.

The installation of the surge protective devices on such services addresses multiple issues:

- Eliminating potential differences to service conductors and thereby reducing the risk of flashover and possible resulting fire (IEC 62305-3)
- Providing protection to structure electrical/electronic equipment against impulses from direct or indirect flashes to the services (IEC 62305-4)
- Correctly located and installed protection (coordinated protection) will also reduce the risk of equipment damage from impulses generated by switching or faults within the electrical circuits
- Is a key part of the Lightning Electromagnetic Impulse LEMP protection measures

The issues of selection and installation of surge protective devices are complex, and made more difficult by requirements being covered in EN 50164-1, -2, -3 & -4, with reference to other standards including EN 50164-3, EN 61643 series, ITU-T K.20 & K.21 and IEC 61000-4-5. As surge protection is not well understood by many in the lightning protection installation industry, this document introduces the subject and covers the

main requirements of surge protection separately in **Chapter 17**.

12.2. SEPARATION DISTANCE REQUIREMENTS

The separation distance requirements determine what external and internal metallic items need to be bonded to the LPS. Separation distance requirements also apply to internal electrical and electronic circuits, thus it is especially important to consider them with respect to the existing and future use of the building.

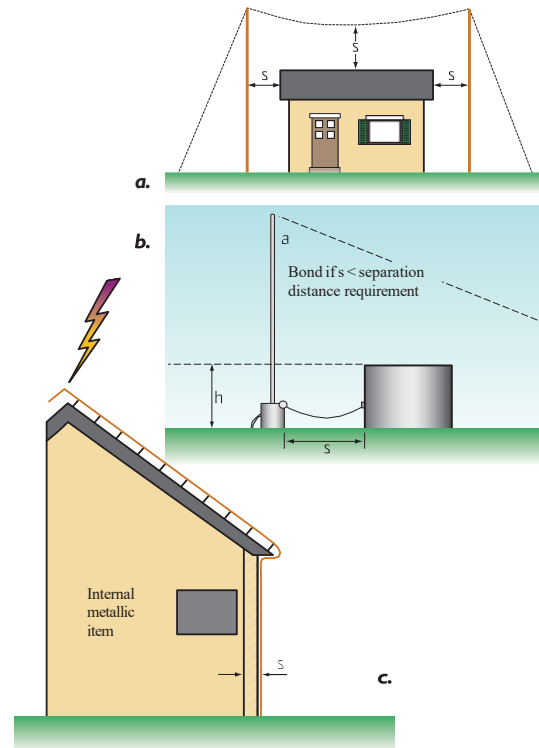
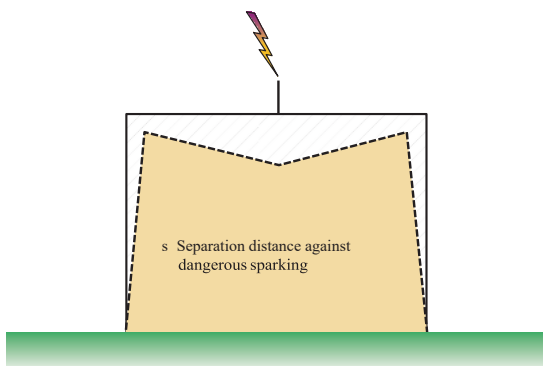


Figure 61. Consideration of air, surface and through material separation distances.

The required distance between the item to be considered and the lightning protection system (to insure that dangerous sparking between them does not occur) is determined by IEC 62305-3, **Section 6.3**. This distance is referred to as the “separation distance” S , where

$$S = k_i \frac{k_c}{k_m} l$$

Where

k_i is a factor that depends upon the chosen lightning protection level.

k_c is a factor that depends upon the number of down-conductors (note that a range is given for 2 or more down-conductors, and depends on the current-sharing between down-conductors).

k_m is a factor that depends upon the electrical insulation material (1.0 for air, 0.5 for concrete and bricks).

l is the length of down-conductor from the point being considered to the closest equipotential bonding point.

Class of LPS	k_i
I	0.08
II	0.06

Figure 60. Separation distance increases with length of down-conductor / air-termination.

III & IV 0,04

Table 28. Separation Distance – Values of k_i .

12. Bonding and separation distances (continued)

Number of down-conductors - n	k_c
1	1
2	1 to 0.5
4 and more	1 to 1/n

Table 29. Separation distance – Value of k_c

$$k_c = \frac{1}{2n} + 0.1 + 0.2 \times \sqrt[3]{\frac{c}{h}}$$

Key

- n total number of down-conductors
- c distance of a down-conductor to the next down-conductor
- h spacing or height between ring conductors

Figure 62. Calculation of k_c .

Appendix C of IEC 62305-3 contains more detailed calculations for k_c . Alternatively, a conservative value of 1 may be assumed.

Also useful is the rearranged equation to determine the maximum length for a given separation distance

$$l = S \frac{k_m}{k_i k_c}$$

Separation distance bonding requirements apply to all conductive parts connected to the equipotential bonding of the structure.

The distance is measured from the point being considered, along the down-conductor, to the equipotential bonding point. The distance is the length of the down-conductor only; the length of the path of the conductor/metallic item in the structure is not important.

For structures using natural down-conductors, such as reinforcing steel within concrete, separation distance requirements can be ignored due to the large number of parallel paths. Separation distance requirements would apply to the air-terminal and external down-conductor connecting into the natural down-conductor. The connection point is the reference point for measurement of the length.

Note that IEC 62305-3 Annex C provides calculations of the partitioning of lightning currents, and Section E.4.2.4.1 provides further examples.

In an isolated lightning protection system, the LPS is designed to maintain the required separation distance to all required items, therefore bonding only occurs at ground level.

1) Referring to **Figure 61 (a)**, and assuming the catenary wire support masts are non-conductive, and that the total length of the conductor from the bottom of the catenary, up to the top of the mast, and down to the ground is 25 m, then the separation distance, S , from the top of the roof to the bottom of the catenary must be greater than:

$$S = k_i \frac{k_c}{k_m} l$$

$$= 0.06 \left(\frac{1.0}{1.0} \right) 25$$

$$= 1.5 \text{ m}$$

(taking the worst case for k_c , and assuming LPS Class = II)

2) Referring to **Figure 61 (c)**, and assuming that the internal metallic item is earthed at the building foundation earth level, along with the downconductor, and that the item is 5 m above the foundation level, then the brick or concrete wall thickness, S , must be greater than:

$$S = 0.08 \left(\frac{1/4}{0.5} \right) 5$$

$$= 0.2 \text{ m}$$

(taking the best case for k_c , n [and] assuming 4 downconductors, and LPS Class = I)

Figure 63. Examples of separation distance calculations

12.3. BONDING OF INTERNAL METALLIC ITEMS AND OTHER SERVICES

In addition to those external items identified in **Section 12.1**, bonding at ground or basement level should be made to internal metallic items such as:

- Water pipes
- Gas pipes
- Heating pipes
- Air ducts
- Lift shafts
- Electrical services

These items should also be evaluated for compliance with the separation distance requirements, as bonding and connection to the LPS at other locations may be required.

For buildings higher than 30 m, it is recommended that equipotential bonding requirements are repeated at a level of 20 m and every 20 m above that.

13. nVent ERICO isolated down-conductor (continued)

13.2. OTHER APPLICATIONS

The separation distance requirements for traditional down-conductors is complex and is a common reason for LPS's to fail to comply with the design standards. While occasionally the designer and installer of the LPS may not be aware of the presence of such items within the wall cavity, more commonly the design violation occurs after the LPS is installed and then low-voltage circuits are added to the structure. The corners of structures are the preferred location for down-conductors, which is also the common location for low-voltage security camera systems. Modern commercial buildings with large glass window frontage provide limited opportunities to run down-conductors and thus the greater likelihood that services are likely also to be located here within the separation distance of the LPS. Unfortunately the installers of such services are not aware of the separation requirements of the LPS, and LPS inspection may not occur, or only identify this issue 1 to 3 years later. The isolated down-conductor provides a design alternative that circumvents these problems.



Figure 65. Conventional down-conductor separation distance problem.

13.3. ISOLATED DOWN-CONDUCTOR DESIGN

To pass the test requirements, the cable design requires more than a conventional down-conductor with high voltage insulation applied. The problem with such a concept is that, at intermediate voltages, a partial discharge may form on the cable surface, leading to thermalization and cable breakdown. Laboratory tests have shown that for standard polyethylene-based cables, this type of flashover can occur even over cable distances of 5 m.

To control the risk of flashover, a semi-conductive outer sheath is used. The semi-conductive sheath provides a known (high) resistance longitudinally from the upper termination to the first earthed bonding point, thereby eliminating partial discharges. This arrangement requires a special layered upper termination fitting involving metallic, semi-conductive, stress relief and anti-tracking components. The primary bond is made to the cable sheath at approximately 2.25 m below the termination. A connection is made to the metallic part of the structure to provide an equipotential bond and controlled voltage gradient to the upper termination.



Figure 66. Isolated Down-conductor and multi-layered insulation and semi-conductive sheath.

14. Earthing

14. EARTHING

The reliable performance of the entire lightning protection system is dependent upon an effective earthing system. Consideration must be given to:

- Providing a low impedance network to dissipate the fast-rising lightning impulse
- Minimization of touch and step potential hazards
- Long term performance of the system - i.e. quality of materials and connections

While the LPS earthing system is normally installed and tested as a dedicated system, it is required by most codes that the lightning protection earthing system be interconnected with other earthing systems. Isolation from the telecommunication, power and other earthing systems is not recommended.

Always adhere to local code/standard requirements.

Material	Application	Requirements
Copper or tin plated copper	Conductor	50 mm ² solid
	Conductor	50 mm ² stranded conductor (minimum strand size 1.7 mm diameter)
	Conductor	50 mm ² solid tape (minimum thickness 2 mm)
	Rod	15 mm solid copper rod
	Rod	20 mm pipe with 2 mm wall thickness
	Plate	500 x 500 mm, 2 mm minimum thickness
Copper-bonded steel	Plate	4.8 m lattice grid — 600 x 600 mm lattice made from 25 x 2 mm minimum material
	Rod	14 mm with 250 µm minimum copper coating — intrinsically bonded (i.e. not clad, should be electroplated)
Galvanized Steel		Not recommended by nVent. Refer to standard for material requirements

Table 30. Earthing material requirements.

Galvanized steel is not permitted by some national codes, due to poor corrosion resistance. The corrosion of galvanized steel is further accelerated by clay and moist soils. Galvanized steel, if used within concrete (Ufer earthing) should not extend into the soil due to accelerated corrosion near soil entry. Galvanized steel in contact with reinforcement steel, under certain circumstances, can cause damage to the concrete (spalling).

14.1. EARTHING RESISTANCE REQUIREMENTS

The general requirement is that the lightning protection earthing system must have a resistance of less than 10 ohms (measured at a frequency different from the power system frequency or multiple thereof).

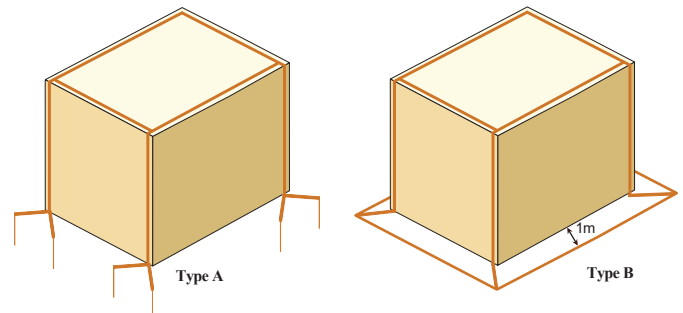


Figure 67. Type A & B earthing systems.

Design details are given on two methods:

- Type A - vertical and/or horizontal electrodes installed outside the structure footprint
- Type B - ring electrode installed outside the structure footprint (counterpoise), or natural earth electrode within footprint (e.g. footing reinforcing)

For these methods the site soil resistivity must be known.

However, these methods have the advantage that if the total electrode length requirements are met, then the earthing is in accordance with the minimum requirements – even if the measured resistance is not less than 10 ohms. Additionally, during installation of the earthing system in accordance with these methods, if the measured resistance of the total system is less than 10 ohms, then the balance of materials would not need to be installed (For type A, the earthing should be symmetrical and completed for all down-conductors, for type B the complete counterpoise should be installed).

Type B is recommended for bare solid rock and for structures with extensive electronic systems or great risk of fire. Type B is preferential from the point of view of providing equipotential bonding between the down-conductors (assuming no ground level equipotential ring is used) and providing better potential control in the vicinity of conductive building walls. For structures with non-conducting walls (brickwork, wood, etc), and no interconnection to foundation reinforcing, a type B system or earth equipotential bonding ring is highly recommended.

Note that the term electrode applies to horizontal or vertical conductors, rods, plates, natural elements and combinations thereof. An earth rod is just one form of possible electrode. Multiple parallel interconnected earth rods are also an electrode.

General requirements:

- The earthing system (and down-conductors) should be located away from entrances and exits of the structure and places where people may congregate. If the earthing system is in locations accessible to the public, then measures should be taken to minimize step potential risks (refer to **Section 3.1.1 & 14.6.3**).

14. Earthing (continued)

- The earthing system should be located away from other metallic buried items (e.g. pipelines and services).
- Test points should be installed between the local electrode sections and down-conductor to enable isolation and measurements of sections of the system during future inspection and testing.

Other earthing methods:

The standard permits other earthing methods, provided that resistance of the earthing network is less than 10 ohms. This allows, for example, more advanced computation methods and modelling to be used to optimize the earthing system. However, without specialist knowledge and design tools, it is not recommended to deviate from the recommended methods.

14.2. TYPE A - VERTICAL AND HORIZONTAL ELECTRODES

Vertical and/or horizontal electrodes are used. There must be earth electrodes installed at the base of each down-conductor. A minimum of two electrodes must be used.

The minimum total length of electrode at each down-conductor is:

- l_1 for horizontal electrodes
- $0.5 l_1$ for vertical (or inclined) electrodes
- Where l_1 is obtained from **Figure 68**

Note that:

- For combinations, the total combined length is considered
- If less than 10 ohms resistance is measured (not at a frequency of, or multiple of the power system frequency), then these minimum requirements do not need to be followed
- The top of vertical electrodes must be buried at least 0.5 m below ground surface. This requirement is to reduce the risk of dangerous step potentials. The use of insulated inspection pits is also considered sufficient
- Frost and freezing soil will limit the effectiveness of any electrode and the presence of electrode in soil that may freeze should not be considered. In this case the length of any electrode in the top 1.0 m of soil should not be considered as contributing to the total length requirement
- Preference should be given to the use of vertical electrodes (refer to **Section 14.7**)

Earth electrodes are permitted to be installed inside the structure, such as through a basement. This can be useful in locations where limited external area is available. Refer to **Section 14.6.2**.

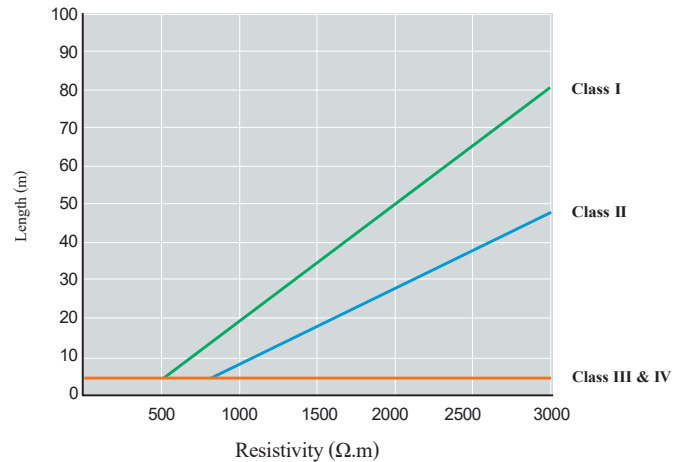


Figure 68. Minimum length of electrodes, l_1 , for type A & type B earthing systems.

Example:

A Class I lightning protection system is installed with 6 down-conductors in 2000 ohm.m soil.

From Figure 68 it is seen that $l_1 = 50$ m. Requirements could be 6 x 50 m horizontal conductors, or 6 x 25 m vertical electrodes

The following details alternative scenarios for each down-conductor, using 1.2 m driven ground rods:

1. Use of single vertical electrode:

25 m of electrode would need to be installed (25.5 m for sites affected by freezing soil), with the top of electrode buried at a depth of at least 0.5 m. (Total requirements 21 x 1.2 m ground rods, 20 couplers and 1 rod clamp)

The installation of a single deep electrode could be difficult to install in many soil types without specialist driving equipment. More practical would be a greater number of parallel connected shorter rods.

2. Use of multiple vertical electrodes:

For sites not affected by freezing soil, a solution could be achieved by 11 parallel electrodes. Each electrode could be comprised of 2 x 1.2 m coupled ground rods. For optimum effectiveness these electrodes should be spaced apart a distance equal to 1 to 2 times their length, i.e. 2.4 to 4.8 m apart.

(Total requirements 22 x 1.2 m ground rods, 11 couplers, 11 rod clamps & 24 to 48 m conductor).

To simplify above calculations, the effect of the vertical conductor interconnecting these rods was not considered. Assuming vertical electrodes were placed at 2.4 m apart, and bare conductor interconnects the rods, then the presence of horizontal conductor has the same effect as adding 1.2 m to each vertical electrode.

14. Earthing (continued)

8 x 2.4 m electrodes would be required. (Total requirements 16 x 1.2 m ground rods, 8 couplers, 11 rod clamps & 17 m of conductor).

For sites affected by freezing soil, as the first 0.5 m of each electrode is considered as not adding to the effectiveness, it is more economic to use less parallel rods. Also as the horizontal interconnection between rods is unlikely to be below the 0.5 m additional depth, its effect should not be included in the calculation. If using parallel 2.4 m electrodes, only the lower 1.9 m would be “effective”, requiring 14 electrodes. A more appropriate configuration may be 6 x 4.8 m electrodes (total requirements: 24 x 1.2 m ground rods, 18 couplers, 6 rod clamps and 24 to 48 m conductor). The design should attempt to find the most effective balance between installation effort (cost) and material cost.

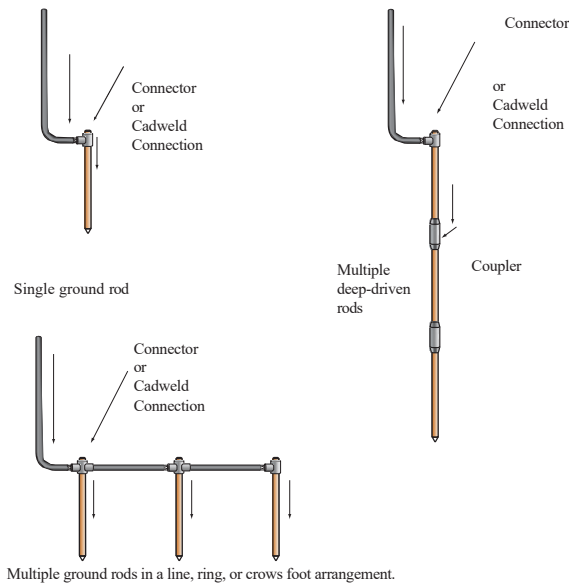
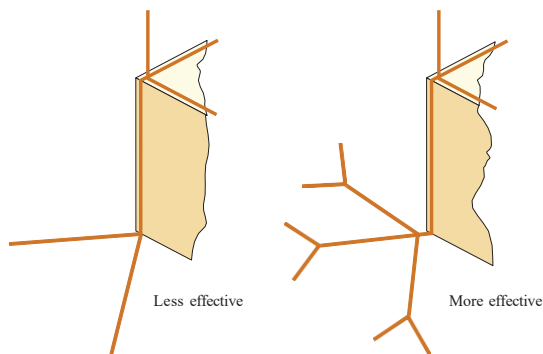


Figure 69. Example vertical electrode arrangements.

Care should be exercised with horizontal electrodes, as long runs are not as effective as a smaller number of shorter lengths (crows foot arrangements). The length of a horizontal electrode should not exceed about 30 m. Other than equipotential rings, the main use of horizontal runs should be for the spacing apart of multiple vertical electrodes.



14.3. TYPE B – RING ELECTRODE

A ring electrode around the perimeter of the structure, or natural elements within the foundation is used.

A ring conductor should:

- Have a mean radius of distance $r_e \geq I_1$ provided from Figure 68
- Be buried at a depth of at least 0.5 m. (practically, the length of any electrode not deeper than 0.5 m should not be considered as contributing to the total length requirement - 1.0 m or deeper for areas subject to permafrost)
- Be installed at a distance of approximately 1 m from structure walls
- Be a closed ring, encircling the structure
- Be in contact with the soil for at least 80% of its length

Note that the buried depth requirement, while helping to improve

the electrode coupling to the soil, also reduces the step potential risk. For locations where ground freezing occurs, greater depth of electrodes should be considered.

While it is stated a requirement is to be a closed ring, encircling the structure, it is permitted to use conductors in the structure such as foundation earthing or permanently connected conductive metal items such as pipes and conduit as part of the ring. Such items must meet the requirements of natural components and allow the ring to be in contact with the soil of at least 80% of its total length. The 80% requirement also allows for situations where the ring conductor may be imbedded in concrete foundations of part of nearby structure, such as retaining walls, etc.

Where the distance r_e would require the ring to be installed at a distance greater than 1 m from the structure, then it is recommended that the ring be installed at 1 m and additional

supplemental horizontal or vertical electrodes are added per the following requirements. At least two equidistant supplemental electrodes should be installed and ideally connected at the each point where the down-conductors connects to the ring electrode.

Additional horizontal electrode length at each down-conductor = $l_1 - r_e$

Additional vertical electrode length at each down-conductor = $(l_1 - r_e) / 2$.

Based on the above requirements, if the building perimeter is greater than 9 x 9 m and resistivity is less than 500 ohm.m, then the length of a ring installed at 1 m distance from the building will exceed the requirements. If the building is less than 9 x 9 m or resistivity greater than 500 ohm.m, then additional electrodes may be required in addition to a ring installed at 1 m distance.

14. Earthing (continued)

Figure 70. Crows foot arrangement.

14. Earthing (continued)

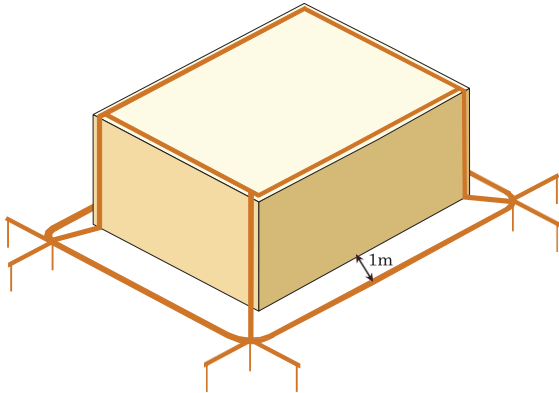


Figure 71. Type B earthing system with additional elements.

Example:

A class I lightning protection system is installed with 6 down-conductors in 2000 ohm.m soil. The building perimeter is 60 m (20 x 10 m).

From Figure 68, it is seen that $r_e = 50$ m (where r_e is the mean radius of the area enclosed by the ring).

Installing a ring electrode at 1 m from building perimeter would require 68 m of conductor, and the ring would contain an area of 264 m² (22 x 12 m).

The equivalent radius of this ring would be 9.16 m

$$\left(\text{radius} = \sqrt{\frac{\text{Area}}{\pi}} \right)$$

Therefore, in addition to the ring, we require additional electrodes at the base of each down-conductor. Either:

6 x 40.84 m $(l_1 - r_e)$ horizontal radials, or

6 x 20.42 m $[(l_1 - r_e) / 2]$ vertical electrodes

14.4. COMPARISON OF TYPE A AND TYPE B ARRANGEMENTS

The specific earthing materials requirements for a structure are affected by soil resistivity, structure shape (perimeter versus area), lightning protection class and earth electrode arrangement (type A versus type B and horizontal versus vertical electrodes). The decision on horizontal versus vertical is affected by available space, soil type, and the availability and cost of digging/driving equipment. However, a number of general comparisons can be made between the different possible arrangements:

- Vertical electrodes are seen as being twice as efficient as horizontal, i.e. they require half the length.
- For Class III and IV systems, a type A system will require less material.
- For Class I & II systems, a type A system will require less material for lower soil resistivity, and type B system will require less materials for higher soil resistivity

14.5. FOUNDATION EARTH ELECTRODES

Concrete reinforced foundations can be used as earth electrodes and are considered to be of type B. There should be at least 50 mm of concrete covering the steel to protect against corrosion. Materials used should meet the minimum requirements of Table 30 (or see IEC 62305-3 Table 14 for further material choices).

Interconnection of the LPS to foundation steel is recommended for all new construction - even where water proofing barriers are used. Foundation steel generally provides excellent equipotential bonding.

Foundation earth electrodes alone should only be used for new construction where the interconnection of the reinforcing steel can be assured (refer to Section 8.3 for rebar weld connection requirements). Note that a dedicated earth electrode conductor can be installed in the concrete rather than using the reinforcing steel, although it is recommended that this conductor be periodically bonded to the reinforcing steel.

Note that only foundations installed below any water proofing barrier will adequately couple with the soil. Where a water proof isolation barrier is used, consideration should be given to installing an earth electrode system below the barrier in the sub-concrete, or use type A or B system.

Special care is required at connections to ensure mechanical splitting of the concrete does not occur.

14. Earthing (continued)

It is common and desirable to connect the foundation reinforcing to the external earthing system. It should be noted that while steel can be safely used in the foundation, when this is connected to an external buried electrode system, the external system should not be steel based (e.g. galvanized steel). Steel in concrete has a similar galvanic potential to that of copper, thus connection of this steel to an external steel system would cause galvanic corrosion of the external steel. An external copper (or stainless steel) electrode system should be used.

The use of pre-stressed concrete should be carefully considered as the lightning current may cause unacceptable mechanical stresses.

Steel piers and other metallic structural items can also be used to supplement the earthing system.

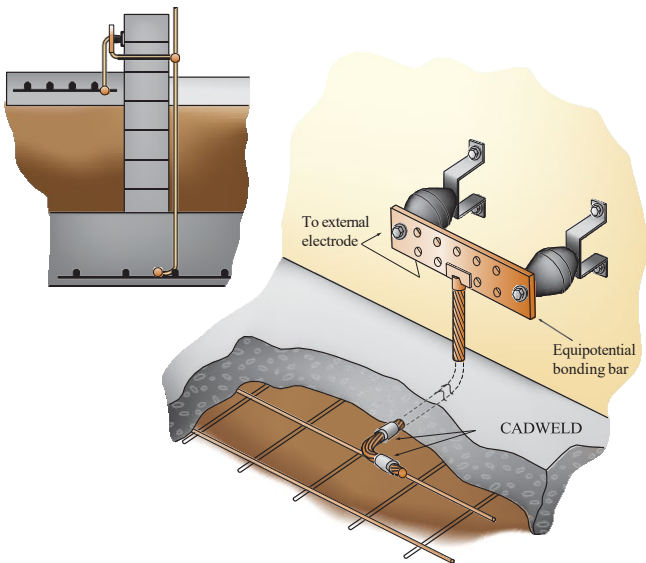


Figure 72. Examples of foundation earthing.

The bonding to foundation reinforcing steel to create an equipotential plane is recommended for all facilities. This is especially useful for large facilities when internal columns are also used as down-conductors. The connection of the internal columns to the foundation can be used as a continuation of the down-conductor to earth electrode circuit. Where the interconnection of the reinforcing steel can not be ensured, dedicated conductors should be used. Dedicated conductors should periodically be bonded to the reinforcing.

14.6. SPECIAL EARTHING MEASURES

14.6.1. ROCKY SOIL

For concrete construction, it is recommended that foundation earth electrodes are used to supplement a ring earth system.

Special advice should be sought where it is not possible to bury the electrodes.

14.6.2. SITES WITH LIMITED AREA

In sites with limited area, it is recommended to use vertical electrodes to achieve the required result. For new construction, the foundation reinforcing can be used, or the earthing electrodes installed below the foundation. In such circumstances, careful consideration of the step voltage risk should be evaluated. An equipotential mesh should be used, or connection to concrete reinforcing in the floor slab.

Where earthing electrodes are installed below the concrete and can not be inspected, only exothermic welds are recommended.

14.6.3. STEP POTENTIAL CONTROL

It is recommended to locate the down-conductors and earthing electrodes in areas not accessible to people. If this is not possible, then additional measures should be used to limit step and touch potentials. This is important for locations where a large number of people may gather.

Measures include:

- Additional ring earths can be installed, at increasing depths. Assuming the initial ring earth is 0.5 m deep and 1 m from the structure, then a second at 1 m depth is installed at 4 m from the structure, a third at 1.5 m depth and 7 m from the structure and a fourth at 2 m and 10 m from the structure. The rings should be interconnected by radial conductors
- Asphalt (non-conducting) 50 mm thick covering the area within 3 m of the electrode
- Gravel 150 mm thick covering the area within 3 m of the electrode

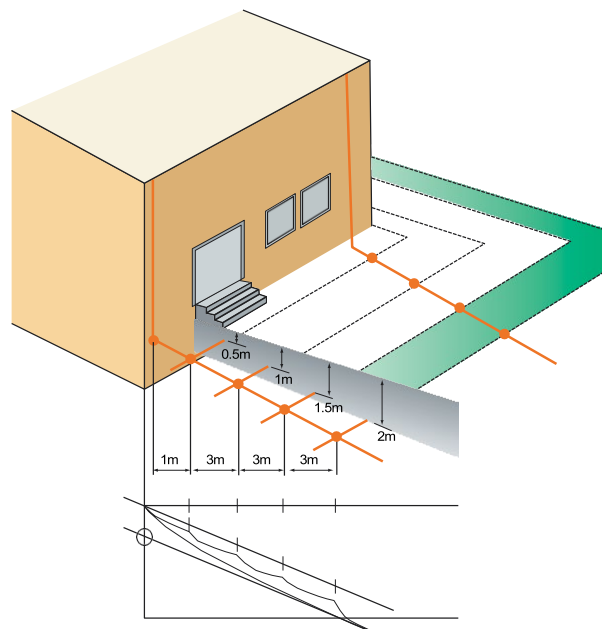


Figure 73. Ring electrodes to reduce step potential.

14. Earthing (continued)

14.7. GENERAL EARTHING ADVICE

14.7.1. RESISTIVITY & RESISTANCE

It is well known that the resistance of an earth electrode is heavily influenced by the resistivity of the soil in which it is driven and as such, soil resistivity measurements are important when designing earthing installations. A knowledge of the soil resistivity at the intended site, and how this varies with parameters such as moisture content, temperature and depth, provides a valuable insight into how the desired earth resistance value can be achieved and maintained over the life of the installation with minimum cost and effort.

Resistivity (measured in ohm.m, Ω.m) is the property of a material that measures its ability to conduct electricity. The commonly used symbol for resistivity is ρ (Greek symbol “rho”). Consequently, soil resistivity is a measure of the resistance between the opposite sides of a cube of soil with a side dimension of 1 meter.

Several methods can be used to measure earth resistivity: the four point method, the variation in-depth method (three point method) and the two point method. The most accurate method is the four point method. A dedicated instrument is used where four stakes are driven into the ground. The depth of the stakes is not more than 1/20th the distance between the stakes. This procedure provides the average resistivity of the soil at a depth equal to the stake spacing. Generally, a survey is completed with a number of measurements from different areas and with different stake spacing to characterize the soil composition.



Figure 74. nVent ERICO test equipment for resistance and resistivity measurements.

Moisture content has the largest influence on soil resistivity because it helps the chemicals in the soil carry the electric current. In general, the greater the moisture content, the lower the resistivity. Moisture retention can be influenced by local climate conditions and electrolytic mechanisms such as mineral content, soil ionization, grain size and packing density. Areas with very dry

Type of soil or water	Typical resistivity ohm.m	Usual limits ohm. m
Sea water	2	0.1 to 10
Clay	40	8 to 70
Ground well & spring water	50	10 to 150
Clay & sand mixtures	100	4 to 300
Shale, slates, sandstone, etc	120	10 to 100
Peat, loam & mud	150	5 to 250
Lake & brook water	250	100 to 400
Sand	2000	200 to 3000
Moraine gravel	3000	40 to 10000
Ridge gravel	15000	3000 to 30000
Solid granite	25000	10000 to 50000
Ice	100000	10000 to 100000

Table 31. Typical soil resistivity (BS 7430-1991).

soil and arid climates may need to use enhancement materials to lower soil resistivity – a more economic alternative to the installation of an extensive earth electrode system.

British Standard BS 7430:1998 Code of practice for earthing provides the following calculations that can be used to determine the approximate resistance expected from earth electrodes:

Vertical electrodes

$$R = \frac{\rho}{2\pi L} \left[\log_e \left(\frac{8L}{d} \right) - \right]$$

Horizontal electrodes

$$R = \frac{\rho}{P\pi L} \left[\log_e \left(\frac{2L^2}{wh} \right) + Q \right]$$

Where:

- R = resistance in ohms
- ρ = resistivity of the soil in ohm.m
- L = length of electrode in meters
- d = diameter of the electrode in meters
- w = width of electrode for tape,
or diameter of conductor in meters
- h = depth of electrode in meters
- P and Q are coefficients given in Table 32.

14. Earthing (continued)

Electrode Arrangement		P	Coefficient Q	
			Strip	Round
Single length a)		2	-1	-1.3
Two lengths at 90°		4	0.5	0.99
Three lengths at 120°		6	1.8	2.2
Four lengths at 90°		8	3.6	4.1

Table 32. Coefficients for electrodes.

For vertical electrodes in parallel line the combined resistance Rn can be obtained from:

in which

$$R_n = R \left[\frac{1 + \lambda a}{n} \right]$$

in which $a = \frac{\rho}{2\pi R s}$

Where:

- Rn = combined resistance in ohms
- R = resistance on one rod in isolation (in ohms)
- s = distance between adjacent rods in meters
- ρ = resistivity of the soil in ohm.m
- λ = factor give in **Table 33**
- n = number of electrodes

Number of Electrodes (n)	Factor λ
2	1.00
3	1.66
4	2.15
5	2.54
6	2.87
7	3.15
8	3.39
9	3.61
10	3.81

Table 33. Factors for parallel electrodes in line.

These calculations can be used as an alternative method to determine the earthing material requirements. For example:

A lightning protection system with 8 down-conductors is to be installed in soil with resistivity of 240 ohm.meter. A Type A arrangement is going to be used due to limited area around the

site and to avoid the cost of digging a trench around the perimeter of building.

To simplify the calculations, to obtain less than 10 ohms resistance for the system, each down-conductor will need to be connected to a electrode of 80 ohms or less.

Rather than rearranging **Equation 6**, a best estimate based on experience is trailed. Therefore, calculating effect of 3.6m of electrode (3 x 1.2 m 5/8” ground rods coupled together) predicts a result of 70.2 ohms.

(5/8” diameter ground rod has nominal diameter of 14.2 mm)

$$R = 70.2 \text{ ohms}$$

Thus installation of 3 x 1.2 m 5/8” ground rods at each down-conductor would be sufficient to obtain less than 10 ohms resistance for the system. The actual resistance should be measured and additional remedial efforts used if required to meet the 10 ohm requirement.

This compares with the requirement of 5 m of electrode at the base of each down-conductor if following Type A requirements in **Section 14.2**.

14. Earthing (continued)

14.7.2 GROUND ENHANCEMENT MATERIALS

nVent ERICO Ground Enhancing Material (GEM) is a low resistance, non-corrosive, carbon-based material used to improve the soil composition. Installed in direct contact with the earth electrode, the material improves the interface between the electrode and soil. The material effectively increases the apparent surface area of the conductor improving the resistive and capacitive coupling to the nearby soil. GEM contains cement, which hardens to provide a permanent, low resistance earthing system. As the conductive elements never leach or wash away, it is maintenance free. While GEM contains a cement composition, it is not designed or rated for structural purposes.

In poor soil conditions, the use of GEM can substantially reduce the electrode requirements. In dry periods, unlike clay based materials, GEM does not shrink and lose contact with the electrode, thus providing year round performance.

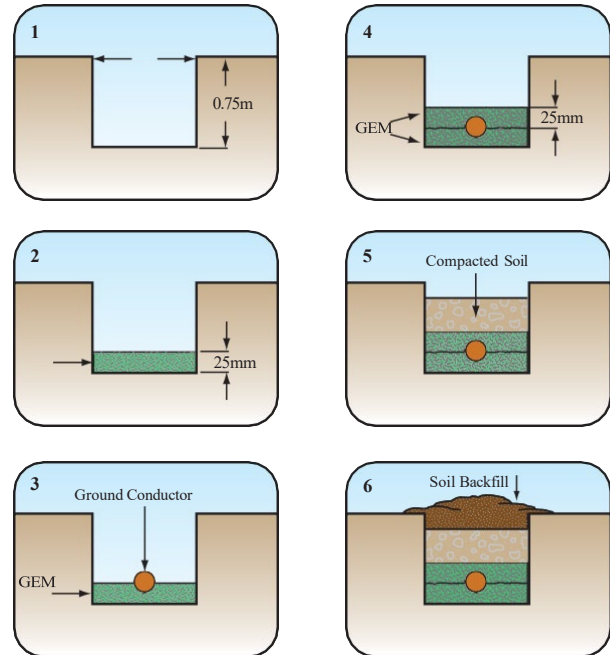
Where drilled holes are used, such as in rocky soil, the use of GEM as a backfill material is an ideal solution. GEM is easy to apply and dramatically lowers resistance.

The use of salt, or salt-based compounds is not recommended due to accelerated corrosion, pollution and the need to periodically replenish the salts due to leaching.

To simplify the calculation of how much GEM is required and the improvement of resistance that is possible, nVent provides a software tool for analysis.

The GEM calculator can be downloaded free of charge from nVent.com/ERICO. Instructions, including minimum PC requirements, are given online.

TRENCH INSTALLATION FOR HORIZONTAL CONDUCTORS



VERTICAL CONDUCTORS

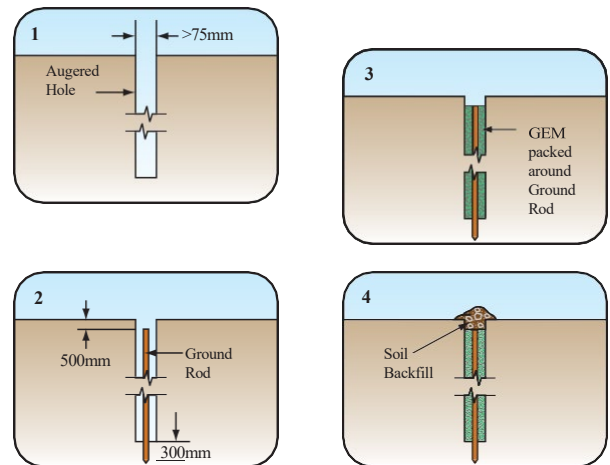


Figure 75. Installation of ground enhancement materials.

Material	Resistivity	Cautions
Concrete	30 to 90 ohm.m	
Bentonite clay	2.5 ohm.m	Shrinks and loses contact with electrode when dries
GEM	0.2 ohm.m	

Table 34. Comparison of earthing materials.

14. Earthing (continued)

14.7.3. EARTH ROD RECOMMENDATIONS

In general, vertical electrodes are more effective than horizontal electrodes because they can be used to penetrate into areas with lower soil resistivity, such as improved soil or regions with a greater moisture content (e.g. water tables). Furthermore, vertical electrodes are ideal for sites with limited area.

Care should be exercised before driving or drilling, to ensure that no buried cables or pipes are directly below the intended location.

Earth rods should be selected on their ability to withstand corrosion (compatibility with soil) and, if connected to other electrode types, galvanic compatibility. While galvanized steel rods are one of the cheapest, they also have a short service life due to much greater corrosion rates. Additionally, galvanic corrosion is accelerated if interconnected to steel in concrete such as foundation earthing. nVent does not recommend the use of galvanized steel electrodes in soil.

The copper bonded electrode is the most cost effective choice. Here, a steel core is used for driving strength with electroplated nickel and copper plating ($> 250 \mu\text{m}$) for good service life.

Figure 76 shows both a copper bonded (electroplated) rod, and a copper clad (sheathed) rod. Both rods have been subject to a bend test, and the clad rod has experienced cracking of the cladding. This would allow corrosion at that point. Copper bonded rods don't suffer from this behavior.



Figure 76. Copper bonded and copper clad earth rods.

Generally, rods are sectional for transportation and ease of installation (1.2, 1.5 or 2.1 m lengths). Earth rods can be coupled using threaded or compression couplings. Compression couplings are normally mated by the rod driving process, while threaded couplings are recommended when rods are to be inserted into drilled holes and backfilled.



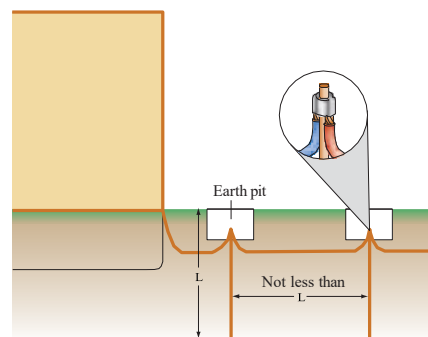
Figure 77. Typical earth rods and accessories.

Solid copper rods are sometimes used, due to the belief that they provide better performance. However the resistance of the steel core and copper bonded rods is more than sufficient for the application. Additionally, solid copper rods do not have the driving strength for deep driving. Solid copper or stainless steel may be an appropriate material for very aggressive corrosion environments.

Stainless steel rods are sometimes used when connections are required to steel towers, or in the proximity of lead-sheathed cables. Stainless steel is also recommended for clay soils and marine environments.

Another common misconception is regarding the earth rod diameter. While increasing diameter increases coupling with the soil, this is not cost effective. A doubling of diameter only leads to approximately a 10% lowering of the resistance. The mechanical strength of a larger diameter rod is useful when driving through rocky soil. A larger diameter rod requires more driving force due to the larger surface area. GEM is a cost effective method for increasing the apparent diameter of a standard, smaller diameter earth rod.

When deep driving of rods is not practical, a common alternative is to use parallel rods. The separation distance of the rods should be no less than their depth. This ensures that the regions of high current density in the soil do not overlap, reducing effectiveness. Only minor improvements will be gained by larger separations.



14. Earthing (continued)

Figure 78. Recommended earth rod separation.

16. Special Situations

15. INSPECTION AND TESTING

The completed lightning protection system should be inspected by specialists at regular intervals as specified in **Table 35**. In structures exposed to severe weather, harsh atmosphere or with high risk factors, more frequent inspections and testing are recommended. IEC 62305-3 Annex F.7 provides recommended procedures for inspection and testing.

Protection Level	Visual Inspection (years)	Complete Inspection (years)	Critical Systems Complete Inspection (years)
I and II	1	2	1
III and IV	2	4	1

Table 35. LPS inspection interval, after inspection and testing done at installation time.

16. Special Situations

16. SPECIAL SITUATIONS

16.1. TALL BUILDINGS

For buildings taller than 30 m, additional equipotential bonding of internal conductive parts should occur at a height of 20 m and every further 20 m of height. Live circuits should be bonded via SPDs.

On structures taller than 60 m, the risk of flashes to the sides of building is increased. Air-termination systems are required to be installed to protect the upper 20% of the sides of the structure.

The same placement rules used for roofs should apply to the sides of the building. While the mesh method is preferable, particularly if using natural components, protection is permitted using horizontal rods and rolling sphere method. However, horizontal rods on most structures are impractical due to window washing access equipment, etc.

For structures taller than 120 m, the standard recommends that all parts above 120 m be protected. It is expected that due to the height and nature of such a structure, it would require a design to LPL I or II (99% or 97% protection level). For tall buildings, the actual risk of flashes to the side are estimated by the industry to be less than 2%, and typically these would be the smaller lightning flashes, e.g., from branches of the downward leader. Therefore, this recommendation would only be appropriate for high risk locations or structures.

Building Height (m)	Requirement
>30	Additional equipotential bonding
>60	Protection against side flashing to top 20% of structure required.
>120	Protection to all parts above 120 m recommended by standard

Table 36. Requirements for tall buildings.

17. Surge Protective Devices

17. SURGE PROTECTIVE DEVICES FOR LOW-VOLTAGE POWER DISTRIBUTION SYSTEMS

As the subject of surge protection is not well understood by many in the lightning protection industry, this chapter introduces the basic concepts as well as providing specific installation recommendations for the protection of the low-voltage power distribution system (the electrical service or AC power supply) and telecommunication and signalling networks. Therefore, information outside that of IEC 62305 series is provided. For those familiar with the subject, the main requirements of IEC 62305 series are covered in Sections:

- 17.4 SPD requirements for facilities with lightning protection system
- 17.5 SPD requirements for facilities without lightning protection system

If a lightning protection system is required, then surge protective devices (SPDs) on the electrical/electronic services are mandatory.

The absence or presence of surge protection within a facility influences the overall risk, thus several different SPD requirements are possible from the risk assessment outcome:

- A lightning protection system and surge protection are required
- A lightning protection system is not required, but the risk assessment shows that services require SPDs due to high risk of lightning to, or nearby, the service
- A lightning protection system is not required as the installation of SPDs (alone or with other measures such as fire extinguishers, etc) would reduce the overall risk to below the tolerable level
- A lightning protection system and surge protection are not required

The BS EN 62305-2 implementation of the IEC/EN standard has additional statements concerning surge protection in the National Annex NB.3. These are associated with the assessing of a lower probability of risk when improved specification and coordination of surge protection is utilized. If surge protection is installed to these requirements, then as improved levels of protection to the electronic equipment within the structure is provided, lower levels of risk management parameter PSPD (Probability of failure on internal systems or a service when SPDs are installed) can be used, potentially lowering the overall risk levels.

It should be noted that IEC 62305-3 primarily addresses reducing the risk of fire caused by a flashover of the services by limiting voltage to below the insulation withstand of the service. IEC 62305-4 addresses the issues of protection of the service and the more sensitive electronic equipment that is typically connected to the service.

17.1. SURGE PROTECTIVE DEVICES AND TRANSIENT VOLTAGES

17.1.1. WHAT IS A SURGE PROTECTIVE DEVICE?

Surge protective device (SPD) is the IEC term given to a device intended to limit transient voltages and divert surge current. Around the world these products are referred to by many other names, such as surge arrester, surge diverter, arrester, suppressor, diverter, lightning arrester, voltage suppressor, transient voltage surge suppressor and overvoltage arrester. Within some industries and regions these alternative names may apply to a defined classification, but essentially these devices are all SPDs. SPDs are made with different technologies, and often these are the basis for other names, such as spark gaps, arc gaps, gas discharge tubes (GDTs), metal oxide varistors (MOVs), etc.

SPDs contain at least one non-linear component, which under specific conditions transitions between a high and low impedance state. At normal operating voltages the SPDs are in a high impedance state and do not affect the system. When a transient voltage occurs on the circuit, the SPD moves into a state of conduction (a low impedance) and diverts the transient energy/current back to its source or ground. This limits (clamps) the voltage amplitude to a safer level. After the transient is diverted, the SPD will automatically reset back to its high impedance state.

17.1.2. WHAT ARE TRANSIENT VOLTAGES?

When a lightning flash occurs to a structure or service the injected lightning current causes a rapid rise in voltage due to the impedance of the conductor. It is this voltage that can exceed the rating of the insulation of the service, resulting in a flashover, and/or the voltage may exceed the withstand of the connected equipment, causing extensive equipment damage.

Voltage transients are one type of power distribution system disturbance that can damage electrical and electronic equipment, or affect its operation. As SPDs are often incorrectly thought to offer protection against a wide range of power distribution system disturbances, the main types of power quality problems and solutions are briefly described. With power quality problems, it is important to correctly identify the problem(s) in order to ensure that the intended preventative equipment is suitable.

17. Surge Protective Devices (continued)

NORMAL (NOMINAL) SUPPLY

Normal supply is a sinusoidal waveform of nominal frequency 50 or 60 Hz. The voltage typically quoted is the rms (root mean square) measurement. In most power distribution systems the normal voltage is supplied in a range of nominal (target) $\pm 6\%$.

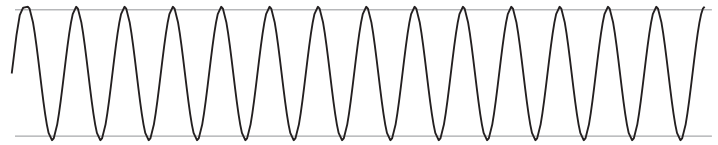


Figure 79. Normal voltage supply.

TRANSIENT VOLTAGE

A transient voltage is a large voltage with a very short duration (microseconds) impressed upon the normal supply. The transient voltage may be in the magnitude of several thousands of volts.

Even though these events are of a very short duration, the high peak voltage is often sufficient to break down sensitive electronic equipment. The usual result is that the equipment stops operating with a blown fuse. Unfortunately the fuse, being a thermal device, probably blew some time after the transient had already passed through to damage susceptible semiconductor components.

Lightning is blamed for many such transients and indeed is a prime culprit. However, by far the largest number of voltage transients in urban and office environments are caused by power switching transients. Switching of inductive loads such as motors, air conditioning plants, domestic appliances and even the office photocopier can cause transient of many thousands of volts. A switching impulse typically has a lower peak voltage, but longer time duration. It is estimated 85% of all power

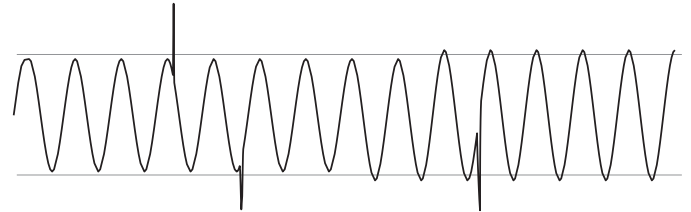


Figure 80. Transient voltage.

quality problems are due to transient voltages, most of these being switching transients produced within the facility.

A transient voltage may also be referred to as “spike”, “glitch” or “voltage impulse”.

SPDs offer cost effective protection against lightning induced transients, and smaller switching transients.

TEMPORARY OVERVOLTAGE (TOV)

An overvoltage is where the power distribution system voltage increases above “normal” voltage for a period of time. Although there is no standard definition, it is commonly accepted that overvoltages are those that occur for a few cycles of the supply voltage up to periods of a few seconds in duration. A short term overvoltage generally has little effect, but an extended duration or abnormally high magnitude can cause equipment to overheat and fail.

A short duration overvoltage may also be referred to as a “swell” or “surge”. The term temporary overvoltage (TOV) is often used to define a short term condition that returns to normal without protective equipment intervention/operation, while abnormal overvoltage refers to a large overvoltage typically due to a fault condition where protective equipment operates to remove the overvoltage source.

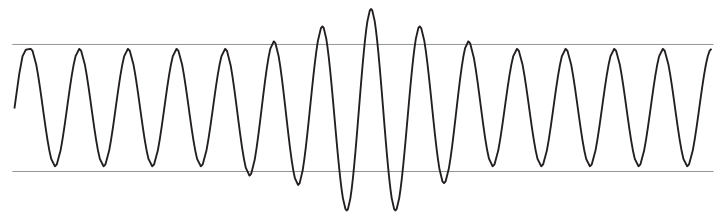


Figure 81. Temporary overvoltage.

A line conditioner provides protection against overvoltages and many online UPS will also protect against overvoltages (some only for the duration of the UPS battery capacity). Excessive temporary overvoltages can catastrophically damage traditional SPDs if their maximum continuous operating voltage is exceeded, even for short durations.

17. Surge Protective Devices (continued)

POWER OUTAGES

A power outage is distinguished by a complete absence of voltage supply. This event may be caused by power distribution system equipment failure, or an accident such as someone cutting a cable. A power outage may also be caused by the operation of an upstream overcurrent protective device removing power from a circuit where an overload or other fault is detected. The duration of a power outage may be from a few tenths of a second to several hours.

The term "dropout" is used to define a momentary power outage of less than one cycle.

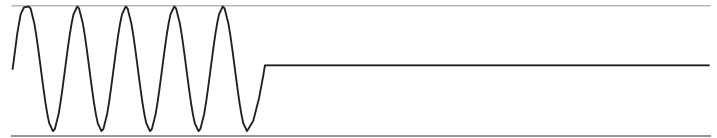


Figure 82. Power outage.

A UPS will protect against power outages for the duration of the UPS battery capacity.

UNDER-VOLTAGE

An under-voltage is distinguished by the power distribution system voltage being less than the "normal" voltage for a period of time. Although there is no standard definition of limits and duration, it is commonly accepted that under-voltages are those that occur for a few cycles of the voltage, up to a few seconds in duration.

These variations may be caused by the power supply authority or by adjacent industries operating heavy loads such as large motors, welders, electric furnaces, etc. Variations typically occur where the power distribution system is heavily loaded or the reticulation feeders are long. Depending upon the type of electrical equipment, and the duration and amplitude of the under-voltage, some equipment may fail to operate as intended under these conditions.

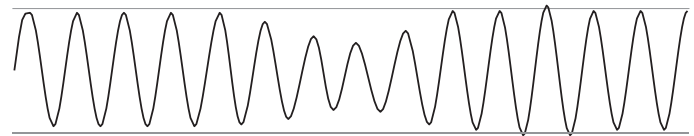


Figure 83. Under-voltage.

An extended duration under-voltage may also be referred to as a "brownout". A short duration under-voltage may also be referred to as a "sag" or "dip".

A line conditioner provides continuous protection against under voltage and brownouts, while an online UPS will only protect against under voltages and brownouts for the duration of its battery capacity.

DROPOUTS

A dropout is a momentary power outage where a portion of one AC voltage cycle is missing. These events are commonly caused by loose connections within the power distribution system. Equipment is affected dependent upon its ability to "ride through" the voltage dropout.

The term "notch" may also be used to describe this event. However, more accurately "notching" is a repetitive event such as caused by the commutation of current from one phase to another.

A UPS will protect against dropouts.

On-line UPS's will protect against frequency variations.

FREQUENCY VARIATIONS

Frequency variation is the deviation of the power distribution system voltage frequency from its nominal value (50 Hz in most of the world, 60 Hz mainly in North America). As the system frequency is set by the speed of rotation of its generators, changes of more than 1% are rare. Frequency variations are more common in supplies fed from small generator systems. Most equipment is generally not affected by frequency variations.

17. Surge Protective Devices (continued)

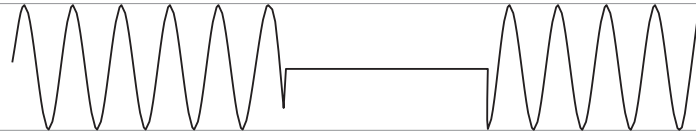
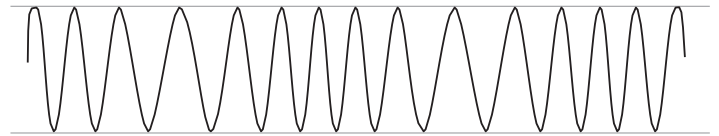


Figure 84. Dropout.

Figure 85. Frequency variation.



17. Surge Protective Devices (continued)

NOISE

Noise is generally defined as the presence of unwanted higher frequency electrical signals that do not fall into the other power quality classifications given here. Noise is often created by electronic switching devices, such as solid state rectifiers and switching power supplies. Noise can cause miss-operations of some sensitive equipment, hum on telephone circuits and distortion on display monitors.

Where noise is suspected, specialist advice is recommended in the identification and resolution of the problem.

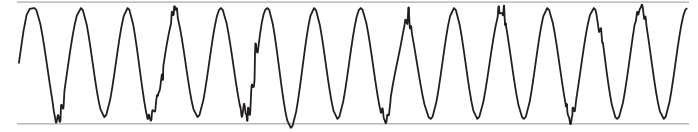


Figure 86. Noise.

HARMONIC DISTORTION

Harmonic distortion is caused by the operation of equipment that draws non-linear current (e.g. solid state rectifiers and switching power supplies) and is evident by the AC waveshape being distorted from its normal sine waveshape. Each cycle of the supply is similarly affected for the duration of operation of the non-linear load.

Where harmonic distortion is suspected, specialist advice is recommended in the identification and resolution of the problem.

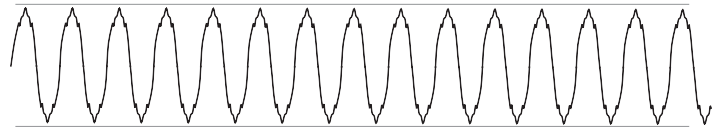


Figure 87. Harmonic distortion.

17.2. GENERAL PROCEDURE FOR SPD SELECTION AND INSTALLATION

The selection and installation of the SPD must consider the main SPD roles:

1. Providing equipotential bonding to the services, reducing the risk of flashovers to/within the services when current from the LPS is injected into the ground and a portion of this current may flow out the service to remote ground points
2. Reducing transient energy entering into the facility from a direct or indirect flash to the service
3. Protecting internal electrical and electronic equipment

For equipotential bonding (role 1), a lightning current SPD is required at the service entrance (i.e. SPD meeting class I tests). This SPD is mandatory for structures with a LPS.

For protection against lightning to the service (role 2), SPDs are also required at the service entrance, but if a LPS is not fitted to the structure, then the SPDs can be used meeting either class I or class II tests.

For internal equipment protection (role 3), in most cases additional SPDs need to be located in sub distribution panels or closer to, or within, the equipment. These SPDs are considered to be secondary protectors, and their operation needs to be coordinated with the service entrance protection. SPDs meeting the either

class II or class III tests are suitable.

17. Surge Protective Devices (continued)

While it is stated that SPDs should be located at the “service entrance”, this is generally not the exact physical location. For practical and safety considerations the SPDs are installed within the main electrical distribution panel, after the main disconnect/ overcurrent device. This allows the power to be isolated to the SPDs if maintenance is required. On large facilities the SPDs may be fed by an isolator device, allowing SPDs to be serviced without the need to remove power from the entire panel/site.

The location, selection and installation of these SPDs should follow local code requirements. In some countries, the wiring from the supply to electricity meter and to the live side of the main switch/overcurrent device are considered to belong to the power company, and installation of SPDs at these points is not permitted, nor recommended. Installation after the main disconnect/ overcurrent device of the main electrical distribution panel is recommended.

If surge protection is required, firstly determine incoming services SPD requirements:

1. Determine the total surge rating for the service entrance SPDs. (Where an external LPS is not required, refer to **Section 17.5**, otherwise refer to **Section 17.4**)
2. Identify the power distribution system type to determine the number and voltage ratings (U_c) of SPDs required (refer to **Section 17.7**)
3. Determine the individual SPD current ratings

17. Surge Protective Devices (continued)

4. Determine back-up overcurrent (fuse) requirements (refer to Section 17.8.1)

Secondly, evaluate installed performance of the service entrance SPDs to determine need for secondary coordinated protection:

Determine number of secondary SPDs, location(s), surge ratings, voltage ratings, back-up overcurrent (fuse) requirements, etc (refer to Section 17.6)

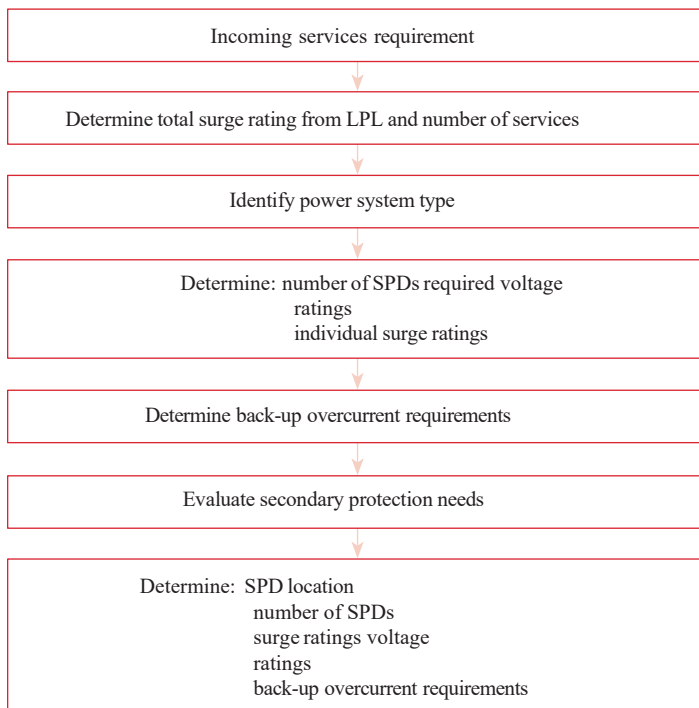


Figure 88. Flow chart for identification of surge protection requirements.

17.3. GENERAL INFORMATION AND TERMS

The IEC 62305 series refers to the following surge protection standards:

- IEC 61643-1 Surge protective devices connected to low-voltage power distribution systems – Requirements and tests (Part 1)
- IEC 61643-12 Surge protective devices connected to low-voltage power distribution systems - Selection and application principals (Part 12)

Part 1 is applicable to manufacturers of surge protective devices, while part 12 has general use (note that future editions of Part 1 will be released as Part 11). However, many of the requirements of Part 12 are overridden by IEC 62305 series, hence is not recommended reading for those only interested in application of

SPDs for lightning protection. These standards however, define much of the terminology used within the IEC 62305 series.

Three types of SPDs are defined, each having a specific test regime (the class of test) and specific marking requirements. The manufacturer of the SPD can elect to test the SPD to one or more classes of test, allowing the SPD to be used in multiple applications.

CLASS I TESTS

The test class I is intended to simulate partial conducted lightning impulses. Therefore for locations such as service entrance protection, a SPD with test class I classification is recommended.

The I_{imp} rating is the method of indicating the current rating for test class I SPDs.

SPDs to this class of test may be referred to as lightning current SPDs.

CLASS II TESTS

The test class II subjects the SPD to impulses of shorter duration. These SPDs are generally recommended for locations with lesser exposure to direct impulses, such as for secondary protection where the SPD provides additional protection downstream of the lightning current SPD. SPDs meeting the class II tests are also suitable for service entrance protection on structures that are not provided with structural lightning protection systems.

The I_n rating is the method of indicating the current rating for test class II SPDs.

SPDs to this class of test may be referred to as overvoltage SPDs, but are not designed to protect equipment against temporary or abnormal overvoltages. They are designed to divert partial lightning currents.

CLASS III TESTS

The test class III subjects the SPDs to voltage impulses. These SPDs generally have a much lower energy withstand capability than SPDs meeting test class I & II. SPDs meeting class III are generally recommended for when the installation of secondary protection is not sufficient for equipment protection. They are suited to the application where protection is provided close to the protected equipment, such as when the equipment is located some distance downstream of class II devices.

The U_{oc} / I_{sc} rating indicates the maximum combination wave voltage/current applied to the SPD. The U_p rating is provided at U_{oc} / I_{sc} .

17. Surge Protective Devices (continued)

It is important to not only consider the test class of the SPD, but the magnitude of the current for which it is rated.

I_{imp} = Impulse current

Peak impulse current withstand with a 10/350 μ s waveshape.

I_n = Nominal discharge current

Essentially the 15 shot rating of the SPD with a 8/20 μ s waveshape. IEC 61643-1 requires SPDs tested to class II test, to withstand 15 impulses at I_n followed by 0.1, 0.25, 0.5, 0.75 and 1.0 times I_{max} .

I_{max} = Maximum discharge current

The maximum single shot current of 8/20 μ s waveshape that the SPD can safely divert.

It is also important that the SPD be selected to safely operate in regard to the power distribution system voltage, and that the SPD can provide sufficient protection to the system/equipment.

U_c = Maximum continuous operating voltage

This is the maximum continuous voltage that can be applied indefinitely to the SPD without degradation or inhibiting its operation. It is important that the SPD be selected such that the power distribution system voltage does not exceed this rating, otherwise catastrophic failure of the SPD can occur. **Section 17.7** details the recommended selection for the

different system types.

U_p = Voltage protection level

The voltage protection level characterizes the performance of the SPD in limiting the voltage across its terminals. The voltage protection level is generally dependent upon the magnitude of the diverted current and its waveshape. The higher the current, the higher the voltage.

U_p is generally stated using I_{imp} for SPDs tested to class I tests and using I_n for SPDs tested to class II tests.

The lower the voltage protection level, the better the SPD. Ideally the voltage protection level provided by the SPD should be less than the flashover voltage of the power distribution system and withstand of the equipment.



Class of Protection	Markings		
I	"test class I" or T1 I_{imp} xx	I_n xx kA	U_p xx kV
II	"test class II" or T2 I_{max} xx kA	I_n xx kA	U_p xx kV
III	"test class III" or T3 I_{oc} xx kA		U xx kV P

Table 37. SPD class of test, markings and typical application.

17.4. SPD REQUIREMENTS FOR FACILITIES WITH LIGHTNING PROTECTION SYSTEM

17.4.1. SURGE RATING

As a result of a lightning flash to the structure, the lightning current will be conducted and injected into the ground. Some of this current will flow from the structure on metallic services to more remote ground points. In the cases of electrical/ electronic services, this current flow will occur "up" through the SPDs and out the services to remote ground points, such as to a remote distribution transformer ground.

The IEC 62305 series takes a worst case approach to the sizing of the SPDs, where 50% of the lightning current is assumed to be injected into the local ground and 50% flows out the services. Where the services are conductive, the current is assumed to divide equally between them. Within an electrical service, the current is assumed to divide equally between the conductors. For SPD selection, the injected current is determined from the maximum current relating to the class of LPS.

17. Surge Protective Devices (continued)

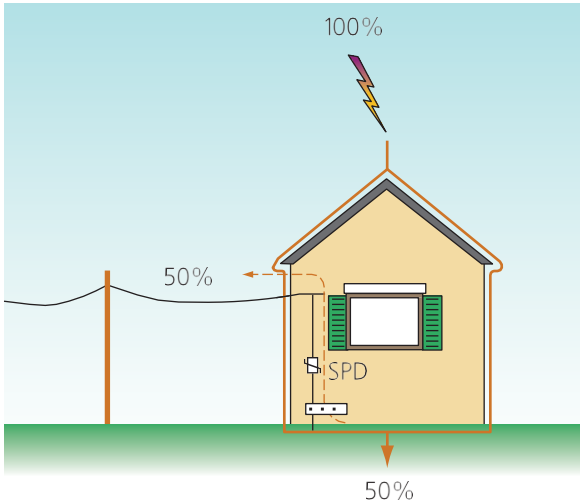


Figure 89. Simplified current distribution.

Figure 89 shows the simplification where a single electrical service is assumed. Often proposed by surge manufacturers, this is based on the rationale that while gas or water services may connect to the structure, it may not be known if they are plastic or metallic. This assumption can dramatically increase the surge rating requirement (and resulting cost).

Class of LPS	Total SPD Surge Current (waveshape = 10 / 350 μ s)
I	100 kA
II	75 kA
III	50 kA
IV	50 kA

Table 38. Total SPD surge rating requirements assuming no other services.

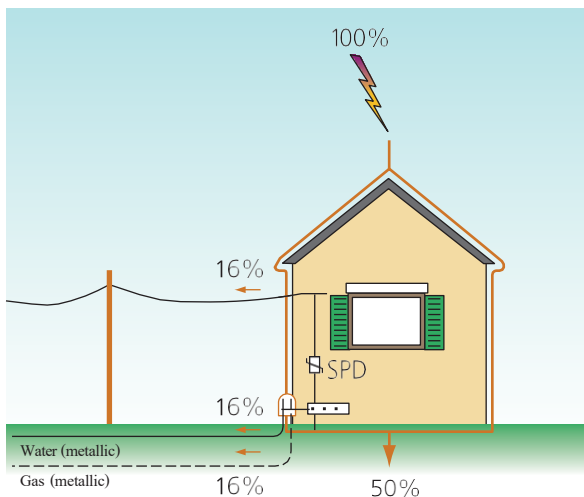


Figure 90. Current distribution between services.

Figure 90 shows another possible scenario where the structure has metallic water services and gas pipes (non-insulated). In determining the SPD ratings, it is not recommended to include the presence of smaller telecommunication service cables in the division of current. Typically telecommunications circuits have a higher impedance, thus a less significant portion of current would flow. Refer to **Section 18** for sizing information for these SPDs.

To determine the individual ratings of the SPDs on each service conductor, information on the number of conductors and the power distribution system type is required. **Section 17.7** provides information to determine the number of individual SPDs required and the surge rating of each.

When an LPS is installed the SPDs selected should be lightning current SPDs (class I test), with an I_{imp} rating equal or greater than the requirements of **Section 17.7**.

As previously mentioned, the IEC approach covers the worst case scenario. Recall that the maximum lightning current only occurs in 1% of events, and the lightning protection system earth electrode only conducting 50% is also a conservative selection. This can result in the installation of surge protection whose ratings are greater than the actual circuit's ability to conduct. If the effect of other services is not considered, then dramatic over-sizing can occur. For example, a class I LPS with three phase and neutral electrical service (only) requires SPDs each rated at $I_{imp} = 25$ kA (10/350 μ s) each (refer **Figure 89**). However, in the case of a structure with two other conductive services (water & gas) and with a TN-C-S multiple neutral/earth power system, then the requirements for the phase protection reduces to $I_{imp} = 5.5$ kA (10/350 μ s) each (refer to **Figure 90**).

A more complex calculation method is provided in IEC 62305-1 Annex E that considers the difference between overhead and underground services, including the effect of conductor shields, conduit and resistivity of the soil for underground services.

Finally, there are many who believe that the IEC assumptions just outlined do result in an excessively high I_{imp} surge rating. Indeed, the IEEE® standards on surge protection contain an interesting and frank discussion on this topic (see IEEE C62.41.2 -2002 Annex A). This document states in Annex A, "Accepting the 'requirements' defined in the IEC documents ... raises the issue of a possible contradiction between, on the one hand, the successful field experience in North America of SPD's [of much lower ratings] and, on the other hand, the higher stresses implied by the ... IEC requirements.", and "A narrow and overly conservative interpretation of the parameters identified in the IEC documents could lead to counterproductive and not cost-effective application of SPDs ...". The document then suggests that a maximum surge rating of 10kA 10/350 μ s might be more appropriate.

17. Surge Protective Devices (continued)

17.4.2. VOLTAGE PROTECTION LEVEL

In addition to providing the required surge rating, in order to stop the occurrence of a voltage flashover in the service, the SPD must also provide a voltage protection level lower than the impulse withstand of the insulation of the service. Further, to reduce the risk of damage to connected equipment, the voltage protection level must also be lower than the withstand of the equipment.

While the term voltage protection level is used here, it is important to consider not only the Up of the SPD, but also the voltage protection level provided to the equipment, as the connection leads to the SPD may also add to the voltage seen by the installation. **Section 17.8.2** provides recommended installation methods to reduce the effect of the connecting leads.

The withstand of the power installation is defined in IEC 60664-1 by the use of overvoltage categories. This test regime is focused upon the insulation withstand. It does not evaluate the possible occurrence of incorrect operation of electronic equipment, or degradation.

The IEC 61000 series immunity standards is typically used with electronic equipment to confirm operation under voltage impulse conditions. Therefore IEC 61000-4-5 test results would give a more practical target voltage protection level. However this information is typically difficult to obtain, especially considering all the equipment that may be within a facility.

As this information may be difficult to locate, a more practical approach for 230/400V system is:

1. Assume the main electrical distribution panel can withstand 4 kV and feeds directly to sub distribution panels.

Therefore the service entrance SPD Up rating must be $\leq 2.4 \text{ kV}$ ($4 \text{ kV} \times 0.6$). The 0.6 multiplier allows a 20% margin for the effect of connecting lead, plus a 20% safety margin.

Typically for TN-S type 230/415 V systems, a Class I SPD would be expected to provide a Up in the region of 1600 V, thereby providing improved levels of protection.

2. Install coordinated surge protection in sub distribution panels to protect the panels and connected electronic equipment.

Overvoltage category (impulse withstand category)	Withstand level	Typical equipment of this overvoltage category
I	1.5 kV	Equipment of overvoltage category I is equipment for connection to circuits in which measures are taken to limit overvoltages to an appropriately low level.
II	2.5 kV	Equipment of overvoltage category II is energy-consuming equipment to be supplied from the fixed installation.
III	4.0 kV	Equipment of overvoltage category III is equipment in fixed installations and for cases where the reliability and the availability of the equipment is subject to special requirements.
IV	6.0 kV	Equipment of overvoltage category IV is for use at the origin of the installation.

Table 39. IEC 60664-1 withstand levels of power installations (230/400 V and 277/480 V).

Test Level	Test Voltage
1	0.5 kV
2	1.0 kV
3	2.0 kV
4	4.0 kV

Table 40. IEC 61000-4-5 level and withstand voltage.

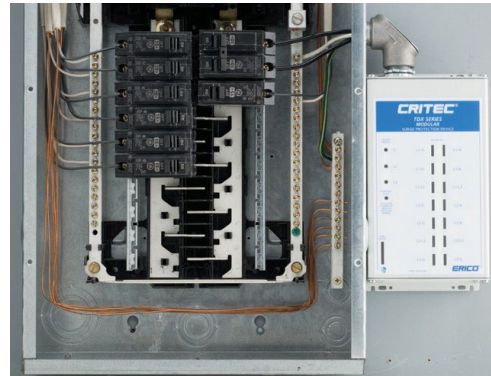
17. Surge Protective Devices (continued)

3. Install a SPD (class II or III test) with $U_p \leq 1500$ V.

The voltage protection level recommendation of 1500 V, may appear to be higher than the accepted susceptibility of electronic equipment which is assumed to be twice its peak operating voltage (650 V for 230 V equipment ($230 \text{ V} \times \sqrt{2} \times 2$)). This is because the U_p rating of a class II SPD is measured and specified at a high current level. In a typical coordinated application, the sub distribution SPD is only exposed to a much smaller current magnitude, and hence its voltage protection level is lower. For example, a typical class II device with $U_p = 1.4$ kV at I_n (20kA 8/20 μ s), will protect to 1 kV @ 5 kA 8/20 μ s and 850 V at 3 kA 8/20 μ s. Such a device has proven effectiveness in this application.

Notes:

- The operation of the SPDs in the main distribution panel and sub distribution panels must be coordinated, If less than 10 m of wiring exist between these points, refer to **Section 17.6.1**.
- The protection level for the main distribution panel alone is generally not sufficient for the protection of electronic equipment. Refer to **Section 17.6.1** if sensitive electronic equipment is installed in the main distribution panel, or connects directly to it.



(a) External mounting SPDs.



(b) SPDs for internal installation to 35 mm DIN panels.

Figure 91. Typical SPD products.

Due to the widespread use of DIN VDE classifications, these categories are provided for reference in **Table 41**. Here voltage withstand is given for typical locations. Conveniently the SPDs are also classified by the manufacturers with the same category letter for their suitability to be used in these locations.

SPD Description	IEC Classification	VDE Classification
Lightning current SPD at service entrance	Class I / Type 1	Class B
Distribution board, or service entrance where structure has no LPS	Class II / Type 2	Class C
SPD installed at equipment to be protected	Class III / Type 3	Class D

Table 41. Current distribution between services.

17. Surge Protective Devices (continued)

17.5. SPD REQUIREMENTS FOR FACILITIES WITHOUT LIGHTNING PROTECTION SYSTEM

17.5.1. SURGE RATING

For structures where lightning protection systems are not required, the risk assessment may indicate that surge protection should be installed upon the service to protect against a direct or indirect flash to the service (when $RI > RT$). **Table 42** provides recommended surge ratings from IEC 62305-1 Table E.2. These ratings are the total for the service, and thus can be divided by the number of conductors in the service to obtain the individual SPD ratings.

While ratings are given as I_{imp} levels, it is permissible to use class II test devices. If class II test SPDs are to be used, the I_n rating is recommended to be 10 times that of the class I test SPD. For example, with a LPL = 1, if the service has three phases and neutral, then 4 x class I test SPDs with $I_{imp} = 2.5 \text{ kA}$ (10/350 μs) could be used, or 4 x class II test SPDs with $I_{max} = 25\text{kA}$ (8/20 μs).

A complex calculation method is provided in IEC 62305-1 Annex E that considers the difference between overhead and underground services, including the effect of conductor shields, conduit and resistivity of the soil for underground services. This method may be appropriate for site such as telecommunication buildings.

The voltage protection level by the installed SPDs must also meet the requirements given in **Section 17.4.2**.

LPL	Flash to the service	Flash near the service	Near to, or on the structure
III - IV	5kA 10 / 350 μs	2.5kA 8 / 20 μs	0.1kA 8 / 20 μs
I - II	10kA 10 / 350 μs	5.0kA 8 / 20 μs	0.2kA 8 / 20 μs

Table 42. Total surge protection ratings for service protection.

17.6. SECONDARY SPD REQUIREMENTS

If the voltage protection level offered by the installed SPD is not sufficient to protect the power distribution system insulation or connected equipment, then additional SPDs are required to lower the voltage protection level. It is important that the installation of this additional protection be coordinated so that one does not affect the other. This is especially important where:

- Different technologies are used for the SPDs being considered, especially where the upstream SPD is of a spark gap or GDT type
- The facility is small, where less than 10 m of wiring exists between the SPDs

17.6.1. SPD COORDINATION

For many situations the main distribution panel can be protected by a SPD meeting class I test requirements, the sub distribution panel with its class II/III SPDs, and sufficient distance between the two panels provides natural coordination. However, if the SPDs are different technologies, or the panels are very close then coordination may not be assured.

Effective coordination is critical where the main distribution panel requires a class I tested SPD for high current withstand and a class II tested SPD to provide a low protective voltage.

It is recommended to discuss with the SPD supplier the coordination requirements for the intended SPDs. However, the following introductory information may be useful in understanding the problem and potential solutions.

The main problems with coordination arise when different technologies are used for protection, such as a spark gap for the service entrance, and metal oxide varistor (MOV) for the secondary protection (**Figure 92**). Spark gaps are often selected for their large current handling characteristics, with MOVs being used for secondary protection due to their superior voltage protection levels and low cost.

17. Surge Protective Devices (continued)

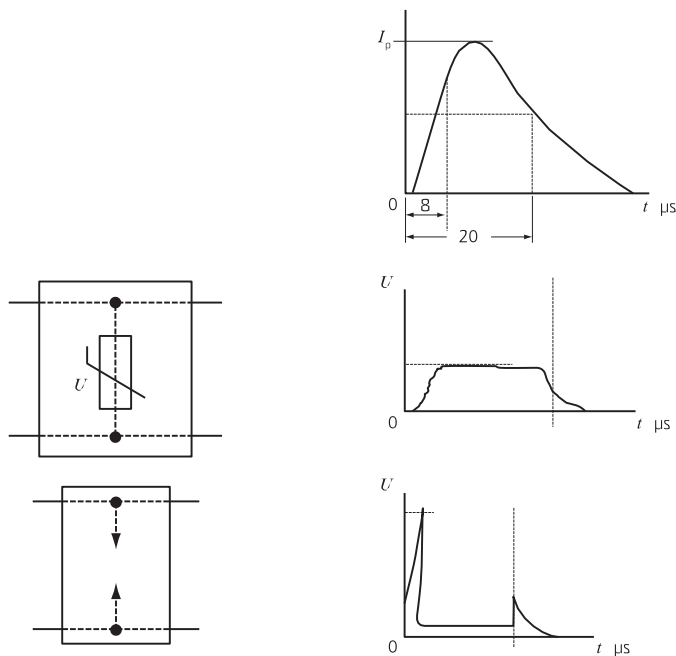


Figure 92. Characteristics of spark gaps and MOVs.

Many commercially available spark gaps “fire” when the voltage reaches the order of 3 to 4 kV, while the typical MOV for 230 volt supply would initiate conduction at approx. 400 V and effectively limit voltages to between 600 and 1200 volts.

The spark gap requires 3 to 4 kV to fire while the MOV limits voltage to approx 800 to 1000 V. Therefore, the MOV will operate first, holding the voltage low enough to prevent the gap from firing, potentially diverting partial lightning current to its destruction. It is as if the spark gap does not exist.

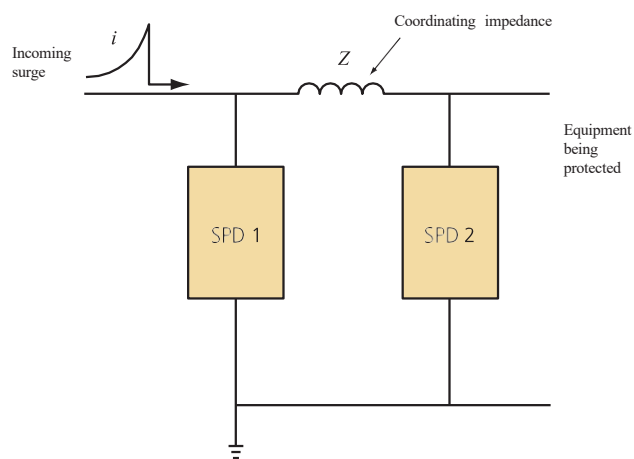


Figure 93. Coordination of SPDs.

The problem is solved by use of a decoupling impedance between the devices. Where sufficient wiring distance between the two panels (> 10 m) exists, the inductance of the wiring is sufficient for decoupling. If sufficient distance is not available, such as in a compact site, or the secondary protection is required to be installed in the same panel, then a purposely designed decoupling impedance is used. One limitation of this approach is that decoupling inductors are typically only available for 32 A and 63 A rated circuits.

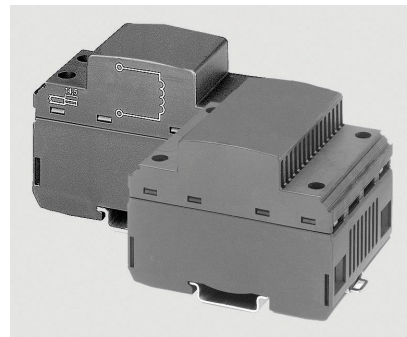


Figure 94. Decoupling devices.

To calculate the required impedance, two current waveshapes are considered; a 10/350 μ s impulse and a slower rate-of-rise of current of 0.1 kA/ μ s.

The coordination of similar technologies such as two MOV products is far less problematic. With the availability of MOV based SPDs with I_{imp} ratings in the range of 25 kA (10/350 μ s), MOV products can be used for both test class I and II applications. The manufacturer of the devices should be consulted for coordination requirements.

17.6.2. EFFECTIVE DISTANCE, THE OSCILLATION EFFECT
SPDs have an effective distance. It is unrealistic to expect a SPD mounted on a main distribution panel to adequately protect a piece of equipment that may be 100 m downstream:

- Oscillation may occur.
- Faults on nearby equipment or circuits may induce transients into the local circuit.
- Ineffective electromagnetic screening from LEMP may induce lightning currents into long cable runs.

17. Surge Protective Devices (continued)

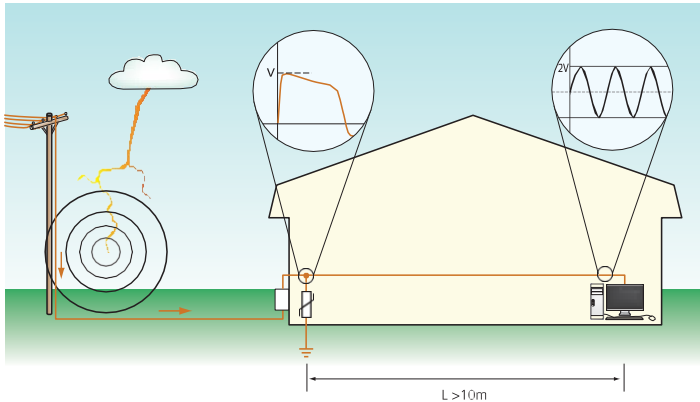
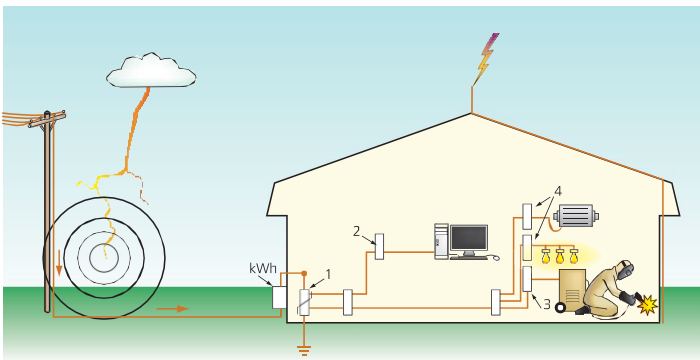


Figure 95. Oscillation effect.



1. Service entrance protection. Class I SPDs
2. Secondary protection for sensitive electronics
3. Secondary protection on circuits generating noise
4. Secondary protection NOT required for robust equipment

Figure 96. Transients from other sources.

An oscillation can occur due to the inductance and capacitance of the wiring, the waveshape of the clamped transient voltage, and load characteristics. The voltage protection level provided at the SPD can effectively double in magnitude as the voltage travels downstream along the wiring. If the equipment to be protected is too distant from the SPD location, it may be that magnitude of the doubled voltage then exceeds the equipment withstand. Additional protection may be required at equipment or within sub panels to counter this problem.

If the installed voltage protection level of the SPD is less than half the equipment's withstand, or the circuit length is less than 10 m,

this problem can be disregarded.

17.7. SELECTION AND CONNECTION CONFIGURATION FOR COMMON POWER DISTRIBUTION SYSTEM TYPES

A number of different power distribution systems are employed in various countries around the world. These are prescribed in local regulations and describe the relationship between the source, exposed or conductive parts of the installation and the local earth. Amongst these are the TN systems (TN-C, TN-S, TN-C-S), TT and IT systems. BS 7430:1998 Code of practice for earthing, or IEC 60364 series provides further details if required. It is critical that the system be identified so the correct SPD surge rating, voltage rating and connection method can be determined.

The extent of a temporary overvoltage condition that may occur during fault conditions is dependent upon the power distribution system type. The SPD maximum continuous voltage rating (U_c) must be selected with this condition in mind. For example, in some 230 V systems, SPDs must be 275 V rated, but for other 230 V systems SPDs must be 440 V rated. Additionally the number of SPDs, type and connection modes can also differ between systems.

Note that while three phase WYE distribution systems are shown, the following can also be used to determine the requirements for single phase circuits. Consult specialist advice for Delta secondary distribution systems (especially ungrounded, or high impedance Delta systems) or WYE no-neutral systems.

IEC 61643 series covers SPDs of up to 1000 Vac, and **Table 43** details the common low-voltage power distribution systems used in residential, commercial and light industrial facilities. Specialist advice is recommended for facilities with medium or high voltage power distribution systems. Note that the term Phase (Ph) is used somewhat interchangeably within the various standards with the term Line (L).

Three-phase	Single Phase
120 / 208	110
220 / 380	120
230 / 440	220
240 / 415	230
277 / 480	240
347 / 600	

Table 43. Common single phase and three phase voltages.

In the industry, the terminology following 3+0, 3+1 and 4+0 logic is used to refer to the configuration of the surge protection. These configurations relate to the interconnection of the MOV and SGD/triggered spark gap SPD types as required for the different power systems TN-C, TN-S, TN-C-S, TT and IT.

17. Surge Protective Devices (continued)

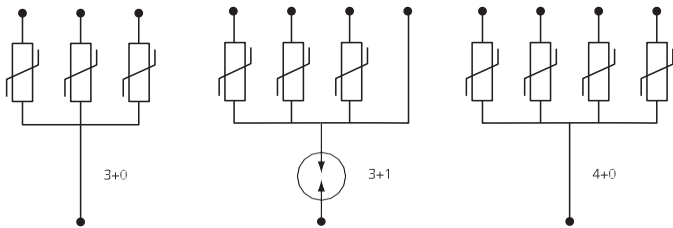


Figure 97. 3+0, 3+1 and 4+0 SPD configurations.

Type “S” or “selective” RCDs are specially designed to have a higher immunity to lightning impulses (to 3 kA 8/20 μ s). Internal filtering desensitizes the detection circuits to harmonics, inrush currents and lightning currents.

There is generally little concern with class III tested SPDs being installed downstream of RCDs. In fact class III tested SPDs are often only installed L-N to protect against differential mode voltages, thus further reducing the risk of interaction with the RCD.

17.7.1. POWER DISTRIBUTION SYSTEMS WITH RESIDUAL CURRENT DEVICES (RCDs)

Within a power distribution system, overcurrent and residual current devices (RCDs) are used for the protection of human lives against shock hazard as well as to protect the structure/equipment and occupants from fire and other hazards that could result from an electrical fault. Similarly, surge protection devices

are installed to also reduce these risks due to lightning currents. It is important that the installation of surge protection devices does not compromise the operation of overcurrent and residual current devices. Where conflicts exist, priority should be given to the overcurrent and residual current devices. Often in the case of RCDs, this resolution requires the installation of the surge protection devices to be installed in a less favorable position.

Residual current devices (RCDs) may also be known as residual current circuit breakers (RCCBs) or earth leakage circuit breakers (ELCBs).

The three main issues with RCDs are:

1. Large lightning current passing through the RCD could cause damage to the RCD, thereby inhibiting its operating and causing a safety hazard
2. Nuisance tripping when surge protection devices installed downstream operate (the current flow to ground can be detected as a potentially life threatening leakage current)
3. Nuisance tripping when large lightning currents are passed through the RCDs. Due to small imbalances in the detection circuit, when large lightning currents are passed and returned via the RCD the RCD may incorrectly detect an imbalance

Generally it is desirable to install SPDs prior to RCDs to avoid situation 1. However, some local codes may not permit SPDs to be installed prior to RCDs. It is important to follow the local code requirement with regard to installation and selection of RCDs.

In other countries, RCDs are only used on branch circuits feeding to wet areas such as bathrooms, hence SPDs can be installed prior to RCDs.

17.7.2. TN-C SYSTEM

In this system, the neutral and protective earth conductor are combined in a single conductor throughout the system. This conductor is referred to as a PEN, a “Protective Earth & Neutral”. All exposed conductive equipment parts are connected to the PEN.

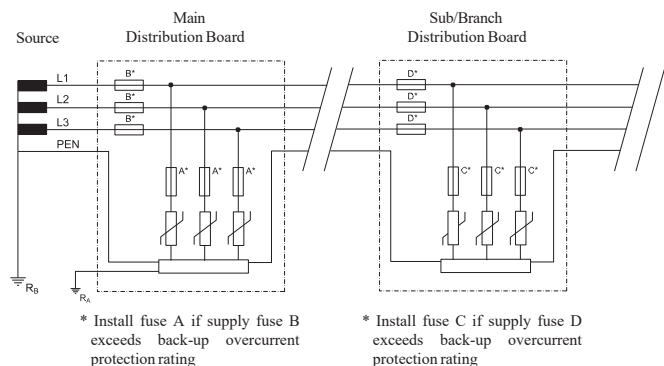


Figure 98. TN-C system identification.

PROTECTION RECOMMENDATION FOR TN-C:

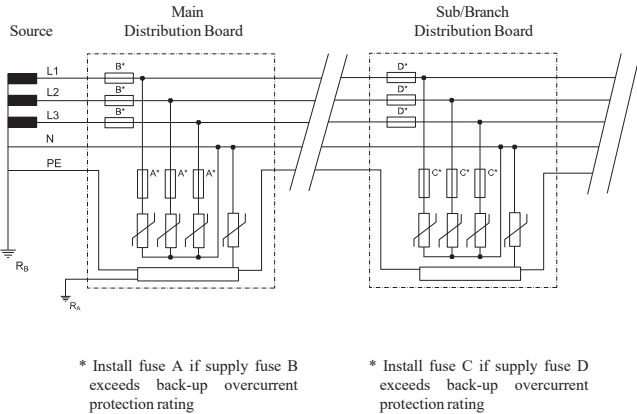
SPDs installed:	Phase to PEN (“3+0”) $\geq 1.1 \times U_0$
U_c :	For three phase systems each SPD to be rated at 1/3 of total requirements (refer to Sections 17.4 / 17.5)
Surge rating:	e, on a 240 V Ph-N system, Ph-PEN protection should have a U_c rating of at least 264 V. Generally a SPD with a U_c rating of 275 V would be selected for 220 to 240 V systems.

For sites where known poor power regulation exists, a U_c of at least $1.3 \times U_0$ is recommended, such as “320 V” SPDs, or nVent’s TD technology.

17. Surge Protective Devices (continued)

17.7.3. TN-S

In this system, a separate neutral and protective earth conductor are run throughout. The Protective Earth (PE) conductor is normally a separate conductor, but can also be the metallic sheath of the power cable. All exposed conductive equipment parts are connected to the PE conductor.

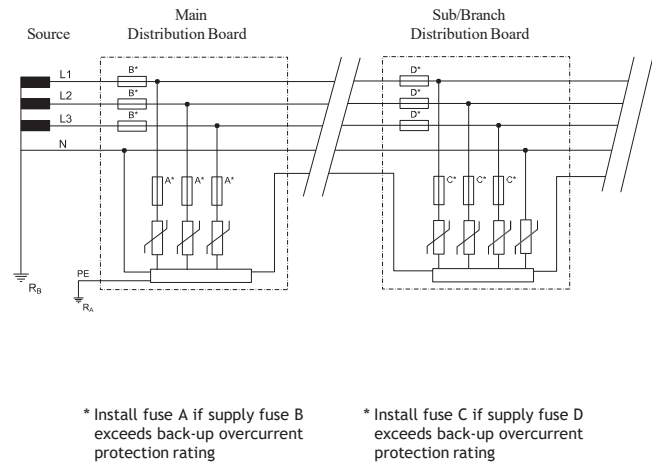


SPDs shown connected L-N and N-PE.
May also be connected L-PE and N-PE.

Figure 99. TN-S system identification.

17.7.4. TN-C-S

In this system, the supply is configured as per TN-C, while the downstream installation is configured as per TN-S. Separate neutral and protective earth functions combine in a single PEN conductor. This system is also known as a Multiple Earthed Neutral (MEN). The protective conductor may also be referred to as the combined neutral earth (CNE) conductor. The supply PEN conductor is earthed at a number of points throughout the network and generally as close to the consumer's point-of-entry as possible. All exposed conductive parts are connected to the CNE conductor.



SPDs shown connected L-PE and N-PE. May also be connected L-N and N-PE.

Figure 100. TN-C-S system identification.

PROTECTION RECOMMENDATION FOR TN-S:

SPDs installed:	Phase to PE ("4+0") Neutral to PE
U_c :	$\geq 1.1 \times U_0$
Surge rating:	For three phase systems each SPD to be rated at 1/4 of total requirements (refer to Sections 17.4 / 17.5)

e, on a 240 V Ph-N system, Ph-PE and N-PE protection should have a U_c rating of at least 264 V. Generally a SPD with a U_c rating of 275 V would be selected for 220 to 240 V systems.

For sites where known poor power regulation exists, a U_c of at least $1.3 \times U_0$ is recommended, such as "320 V" SPDs, or nVent's TD technology.

"3+1" configuration is also permitted, but this is not recommended as it does not offer as lower protective voltages to the installation and requires a larger current rated SPD for N-PE circuit.

PROTECTION RECOMMENDATION FOR TN-C-S:

SPDs installed:	Phase to PE Neutral to PE ("4+0")
U_c :	Note that at main distribution panel, the Neutral to PE SPD is not required due to presence of MEN connection ("3+0"). However, for convenience a SPD may be installed in this mode. For sub distribution panels N-PE SPDs are required.
Surge rating:	$\geq 1.1 \times U_0$

For three phase systems each SPD to be rated at 1/4 of total requirements (refer to **Sections 17.4 / 17.5**)⁽¹⁾

IEC 62305-1 E1.2 details that if the neutral conductor has multiple earths, such as from nearby connected facilities on the same supply, then the neutral conductor may have a lower impedance taking a larger portion of the current. In this case the neutral conductor may take up to 50% of the current, with each phase taking 17%. Thus allow the sizing each of the three phase connected SPD to be 17% of that service's total.

For example, on a 240 V Ph-N system, Ph-PE and N-PE protection should have a U_c rating of at least 264 V. Generally a SPD with a U_c rating of 275 V would be selected for 220 to 240 V systems.

For sites where known poor power regulation exists, a U_c of at

17. Surge Protective Devices (continued)

least $1.3 \times U_0$ is recommended, such as “320 V” SPDs, or nVent’s TD technology.

17. Surge Protective Devices (continued)

17.7.5. TT SYSTEM

A system having one point of the source of energy earthed and the exposed conductive parts of the installation connected to independent earthed electrodes.

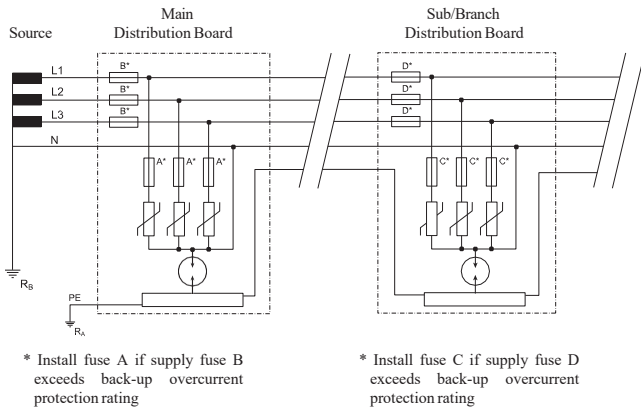


Figure 101. TT system identification.

PROTECTION RECOMMENDATION FOR TT:

	Phase to Neutral
SPDs installed:	Neutral to PE via GDT/triggered spark gap type SPD ("3+1")
U_c :	$\geq 1.7 \times U_o (\sqrt{3} \times U_o)$
Surge rating:	For three phase systems each Ph-N SPD to be rated at 1/4 of total requirements (refer to Sections 17.4 17.5)

For example, on a 240 V Ph-N system, Ph-PE and N-PE protection should have a U_c rating of at least 415 V. Generally a SPD with a U_c

rating of 440 V would be selected for 220 to 240 V systems.

In the TT system, in order for overcurrent protective devices

(fuses and circuit breakers) to operate in the intended manner, it is important that SPDs must not connect directly from phase to protective ground, but from phase to neutral and neutral to ground. Therefore, the Neutral-to-PE SPD carries both the PE to neutral impulse current and the PE to phase impulse currents. This SPD is recommended to be a GDT (Gas Discharge Tube) or triggered spark gap technology, due to their generally superior energy handling characteristics. In general GDTs should not be installed on live conductors (line/phase conductors), due to their poor power follow current extinguishing ability. It is recommended to check with the manufacturer on this issue.

17.7.6. IT SYSTEM

A system having no direct connection between live parts and earth, but all exposed conductive parts of the installation being connected to independent earthed electrodes. The source is earthed through an impedance (to limit fault currents).

Due to the high voltages that can occur in the IT system under fault conditions, the installation of SPDs can be problematic. SPDs must be installed with sufficiently high U_c ratings (typically higher than the L-L voltage) to reduce the risk of damage.

This however, creates challenges in attempting to provide low voltage protection levels. In all cases, the selection should be biased towards the selection of a sufficiently high U_c rating.

Most installed IT systems do not utilise a neutral conductor; equipment is powered from line to line.

The IT system is typically used in older installations in countries such as Norway and France. It is also used in special applications, such as intensive care wards of hospitals and special industrial applications.

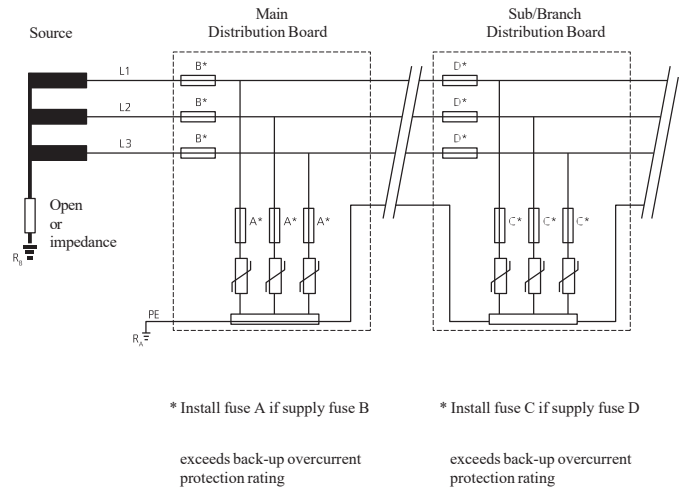
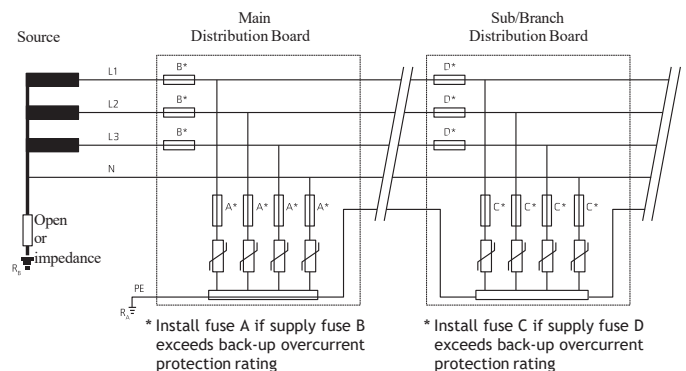


Figure 102. IT system identification – without distributed neutral.



17. Surge Protective Devices *(continued)*

Figure 103. *IT system identification – with distributed neutral.*

17. Surge Protective Devices (continued)

PROTECTION RECOMMENDATION FOR IT:

A) For systems without a distributed neutral:

SPDs installed: Phase to PE

("3+0")

U_c : $\geq V_{L-L} (\geq 1.1 \times V_{L-L}$ recommended)

Surge rating: For three phase systems each Ph-PE SPD to be rated at 1/3 of total requirements (refer to **Sections 17.4 / 17.5**)

B) For systems with a distributed neutral:

SPDs installed: Phase to Neutral

Neutral to PE via gas discharge tube type SPD

("3+1")

U_c : $\geq 1.7 \times U_o (\sqrt{3} \times U_o)$

Surge rating: For three phase systems each Ph-N SPD to be rated at 1/4 of total requirements (refer to **Sections 17.4 / 17.5**). The N-PE SPD to be rated equal to total requirement.

For example, on a 240 V Ph-N system, Ph-PE and N-PE protection should have a U_c rating of at least 415 V. Generally a SPD with a U_c rating of 440 V would be selected for 220 to 240V systems.

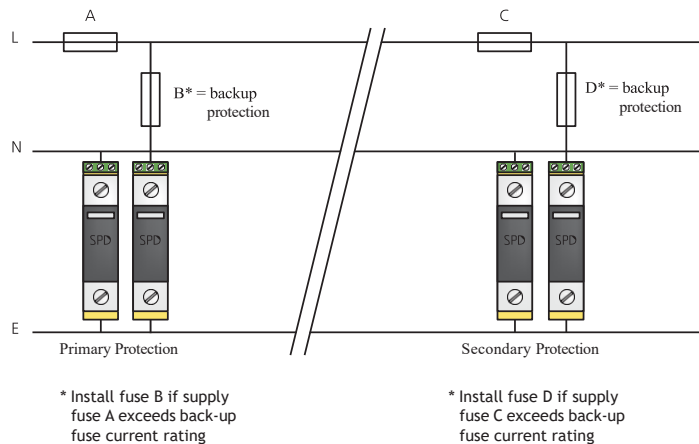


Figure 104. Example of back-up overcurrent protection.

17.8. OTHER INSTALLATION REQUIREMENTS

17.8.1. BACK-UP OVERCURRENT PROTECTION

When installed on power distribution systems with high fault current capability, the SPDs may require a series overcurrent (fuse/circuit breaker) to be placed upstream of the SPD where connected to live circuits. The purpose of this overcurrent device is to avoid overheating and destruction of the SPD in case it is unable to clear a local fault. The installation instruction of the SPD will advise the fuse requirements. Typically, if the circuit where the SPD is to be connected has a upstream fuse greater than SPD requirements, then back-up protection is required. Back-up overcurrent devices must have a short circuit current rating compatible with the installation.

For example, a back-up overcurrent rating for a common 40 kA class II test SPD is 125 A. If the SPD was to be installed on a panel where the main circuit breaker was 125 A or less, then the SPD could be connected directly similar to **Figure 105**. If the main circuit breaker was greater than 125 A, then a back-up overcurrent device of 125 A would need to be installed prior to the SPD, similar to **Figure 106**.

The back-up overcurrent device should be selected in accordance with the SPD manufacturer's advice. Generally a specific fuse type is recommended based on that used during the manufacturer's testing. The device recommended by the manufacturer is generally the largest current rating possible to provide the best SPD performance. Practically this can be problematic due to availability and cost. In general, the smaller the back-up overcurrent device current rating, the better the protection against wiring faults, but the higher the risk that the overcurrent device may rupture during the lightning current, thus removing the SPD from the circuit. For service entrance protection, the use of circuit breakers below 63 A rating may introduce an unacceptable risk of tripping during passage of the lightning current. For secondary SPDs, 32 A is acceptable.

For circuit breakers, curve type D or C is recommended. For fuses, type gL or gG is recommended.

Testing on a range of electromechanical breakers found that a 30 A breaker will typically trip on a surge current of

15-25 kA 8/20 μ s while a 50 A breaker will increase this to 20-60 kA 8/20 μ s.

Note that as wiring distribution methods differ between countries, **Figure 105** and **Figure 106** may not match a given specific practice. These examples show a single phase sub distribution panel configuration.

17. Surge Protective Devices (continued)

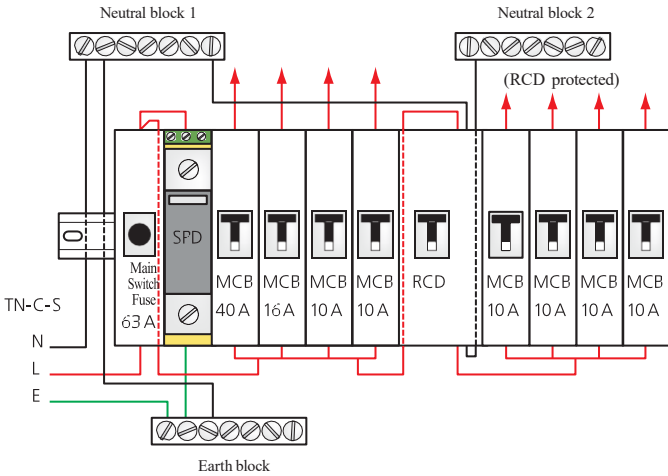


Figure 105. Installation of SPD into typical low current single phase panel with no additional back-up overcurrent protection.

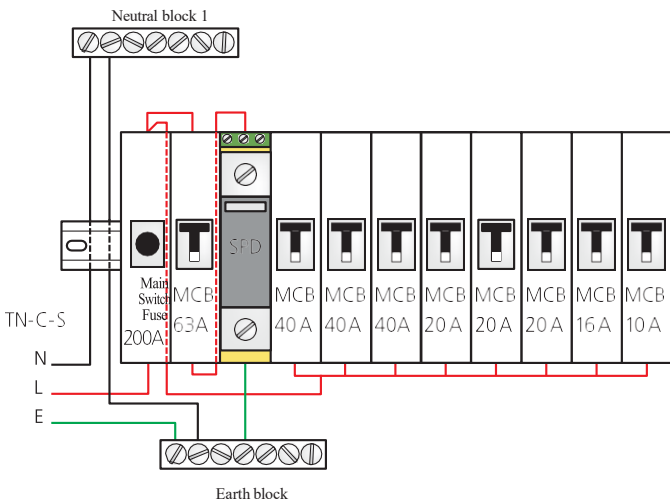


Figure 106. Installation of SPD into higher current single phase panel with back-up overcurrent protection.

17.8.2. EFFECT OF INTERCONNECTING LEAD LENGTH

The physical layout of surge protective devices must ensure that lead lengths are minimized if optimum voltage protection level is to be achieved. As has already been discussed, lightning exhibits an extremely fast rising edge, typically rising many thousands of volts per microsecond. At such rise times, the distributed inductance of the interconnecting leads becomes significant and can not be ignored. **Figure 107** shows the significant increase in voltage which will appear at the protected equipment due to as little as 300 mm of lead length. The importance of ensuring an understanding of the significance of lead inductance is essential if an optimal installation is to be achieved.

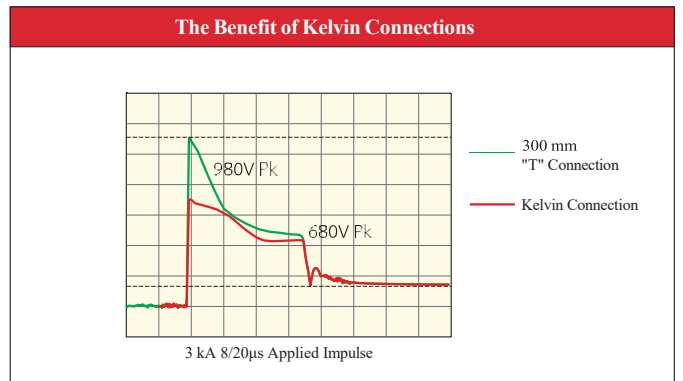
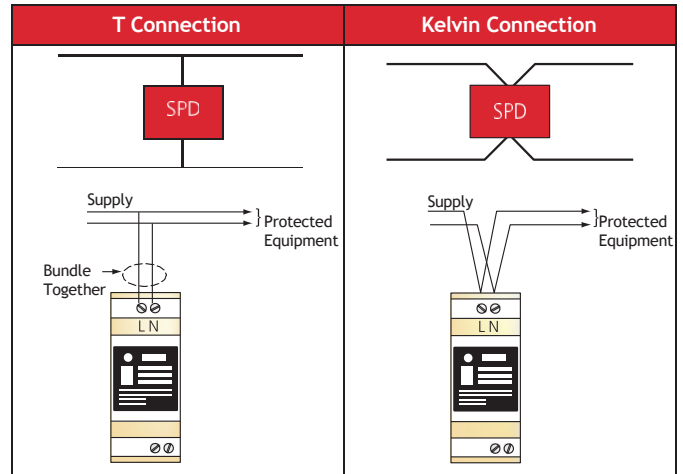


Figure 107. Effect of 300 mm of lead length on the protective voltage which will appear across the load.

17. Surge Protective Devices (continued)

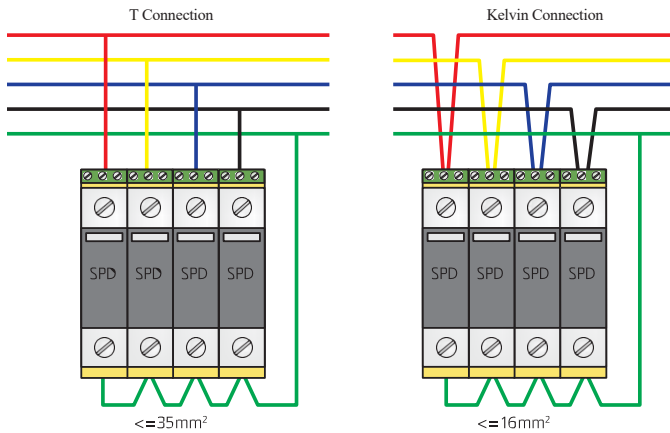


Figure 108. SPD connection methods.

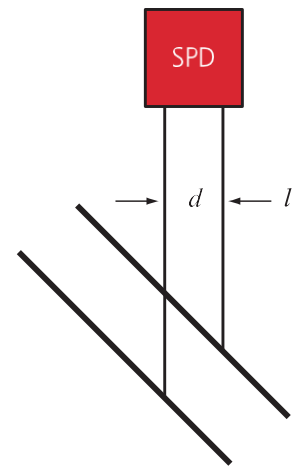
If the length of T-connection wire of the SPD (see **Figure 108**) is less than 0.5 m, then it is sufficient to assume the actual voltage protection level provided at the connection point (U_p/f) is 20% higher than the U_p of the SPD. A Kelvin connected SPD (see **Figure 108**) does not suffer from this problem, and the actual voltage protection level provided to the equipment is that provided by the actual SPD.

- The wire size connecting to the SPD terminals should:
- Be within the manufacturer's recommended range
- Be suitable size to allow sufficient short circuit current to flow to operate the upstream overcurrent protection
- In no case be smaller than EN 62305-4 clause 5.5 (refer Table 1, and shown here as **Table 44**)

Bonding Component	Material	Cross-section mm^2
Connecting conductors for SPD	Class I	5
	Class II	Cu 3
	Class III	1

Table 44. Minimum cross section for conductors connecting to SPDs.

There is little advantage to be gained by using excessively large conductor sizes. As shown by **Figure 109**, the effect of increasing conductor size by a factor of 100, resulted in an improvement of voltage protection level by a factor of 2. Length of the conductor and separation of the conductors are more critical. When long lead lengths can not be avoided, benefit can be obtained by wrapping or twisting the wires together to reduce the separation.



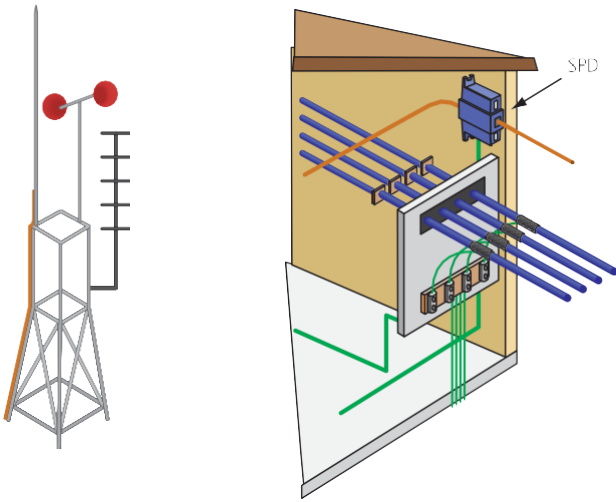
CSA	d	Volt drop (per kA per meter)
1 mm^2	3.2 mm	77.1 V
100 mm^2	14.3 mm	33.9 V
1 mm^2	50.0 mm	236.0 V
100 mm^2	50.0 mm	116.0 V

Figure 109. Effect of conductor size on protective voltage.

17. Surge Protective Devices (continued)

17.9. HIGH RISK SITUATIONS

For facilities with car park lightning circuits fed from an electrical panel in the structure, SPD protection is required to address the risk of a lightning flash to a light pole entering back into the structure. At a minimum, protection should be installed upon the circuit feeding to the lights. A similar situation exists for the obstruction lights on communication towers.



UPSs are often used to protect critical equipment, but it must be remembered that UPSs themselves are often sensitive electronic devices. The inbuilt withstand is generally to 3kA 8/20 μ s levels and is not as robust as purpose designed SPDs. Many UPS systems are fitted with bypass circuits that operate during maintenance, UPS fault conditions or UPS overloads (to supply start up inrush demands of connected equipment). During bypass operation the connected equipment may not be protected by the UPS. There are examples where UPSs have been damaged by a lightning current; the computing equipment is then powered by the bypass circuit, only to have the computing equipment damaged by a following lightning current.

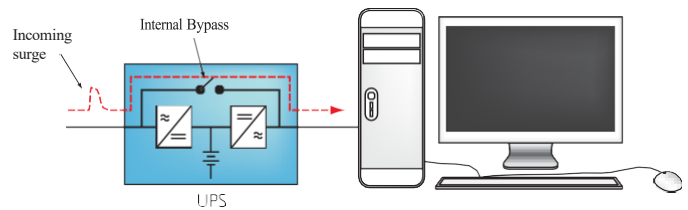


Figure 111. UPSs should be fitted with surge protection.

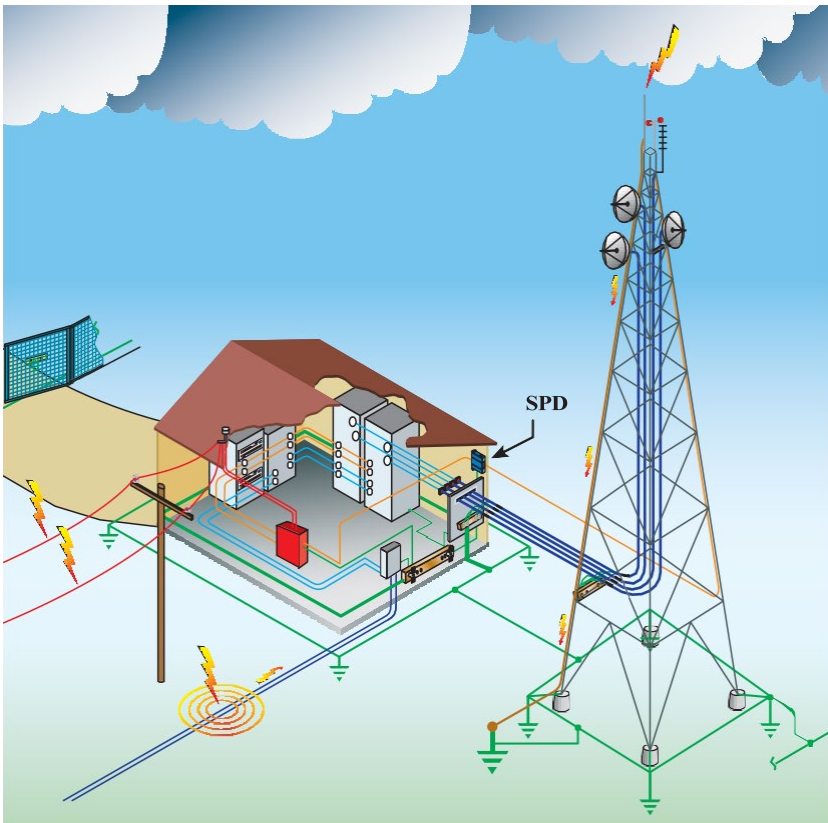


Figure 110. Risks of lightning entering from external circuits.

18. Surge Protective Devices for Telecommunications

18. SURGE PROTECTIVE DEVICES FOR TELECOMMUNICATIONS AND SIGNALLING SERVICES

For the protection of telecommunication and signalling services, two main scenarios need to be considered. The ratings of the surge protection when the LPS is struck and the rise of ground potential causes lightning current to flow out the services to remote ground points, and the rating required in the case of a flash to the service or nearby the service.

Generally telecommunication and signalling services are subjected to lower amplitude currents due to higher impedance to ground of the services, smaller conductor size, etc.

Telephone, cable TV and any other service should be considered, regardless if this enters to the facility, underground or overhead. While underground services are less exposed to the effects of direct flashes, they are still exposed to induced and other threats. Most SPDs available have sufficient surge rating to cover the worst case threat.

When installing telecommunication and signalling protectors, it is critical that the SPD selected be designed for the specific service and intended application. A poorly selected SPD may cause loss of signal quality. It should also be considered if the service provider already installs protection, and where the demarcation point of transition from service wiring to customer wiring exists. Do not install SPDs on circuits owned by the service provider without their consent.

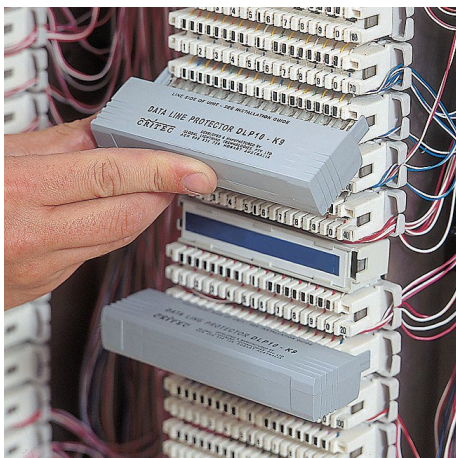


Figure 112 Protection of telephone circuits by plug in surge protection units.



Figure 113. Incoming antenna circuits require protection.



Figure 114. Industrial facilities may require many circuits to be protected.

Protection of CCTV cameras and other devices that are outside of the structure should be carefully considered. Is the equipment within the protection zone afforded by the LPS, and is surge protection provided to the circuit to reduce the energy entering into the facility?

19. OTHER SURGE PROTECTIVE DEVICE APPLICATIONS

The use of galvanized steel electrodes is discouraged within this document. Where galvanized steel electrodes connect to steel reinforcing (via galvanized steel or other conductor materials), serious risk of corrosion of the electrode can occur. If galvanized steel electrodes must be used, then insulating spark gaps can be used to effectively break this galvanic connection to steel reinforcing. Under normal conditions the spark gap isolates and stops the galvanic connection, but under transient conditions the spark gap temporarily operates connecting the two systems to allow lightning current to flow.

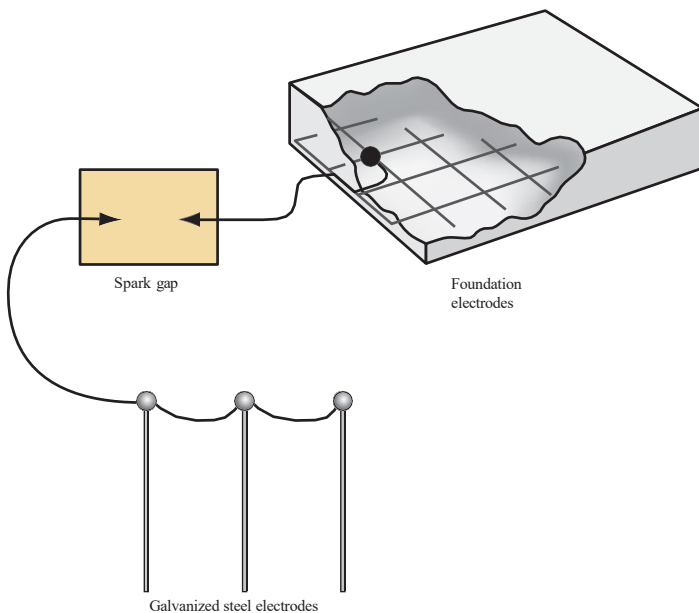


Figure 115. Use of SPDs to avoid corrosion in earthing systems.

Class I test spark gaps with a minimum I_{imp} of 50 kA (10/350 μ s), $U_p \leq 2.5$ kV and complying with EN 50164-3 are suitable for this purpose.

Section 12.3 described the need for the bonding of electrical and electronics circuits for taller structures. It is recommended to seek specialist advice for this application.

20. British Standards

20. BRITISH STANDARD BS 6651 AND EN/IEC STANDARDS

As a CENELEC member, the United Kingdom has adopted the EN 62305 series as British National Standards. These standards are numbered BS EN 62305-1, 2, 3, and 4. With the exception of BS EN 62305-2, the BS EN versions are identical to the EN source.

The British Standard BS 6651 “Code of practice for protection of structures against lightning” was officially withdrawn on the 31st August 2008. After this date, lightning protection designs within the United Kingdom must be implemented using the BS EN 62305 series.

The EN 50164 series standards are also adopted as BS Standards, and materials/components used in BS EN 62305 series designs must meet these requirements.

20.1. BS 6651-1991 COMPARED TO BS EN 62305

The following is provided as a simple comparison of the main BS 6651 requirements, compared to BS EN 62305 series.

Standard	BS 6651	IEC 62305			
Protection level	One	LPL I	LPL II	LPL III	LPL IV
Mesh size	10 x 20 m	5 x 5 m	10 x 10 m	15 x 15 m	20 x 20 m
Rolling sphere	60 m*	20 m	30 m	45 m	60 m
Down-conductor spacing					
Building < 20 m	20 m	10 m	10 m	15 m	20 m
Building > 20 m	10 m	10 m	10 m	15 m	20 m

*20 m for structures with sensitive electronics

Table 45. Comparison of BS 6651 and IEC 62305 design rules.

Down conductor fixing (mm)	BS 6651	Tape & stranded	Round conductors
Horizontal conductors, horizontal surfaces	1000	500	1000
Horizontal conductors, vertical surfaces	500	500	1000
Vertical conductors up to 20 m	1000	1000	1000
Vertical conductors above to 20 m	500	500	1000

Table 46. Comparison of BS 6651 and IEC 62305 conductor fixing requirements.

Minimum roof thickness	BS 6651	Preventing puncture	Puncture permitted
Galvanized Steel	0.5 mm	4 mm	0.5 mm
Stainless Steel	0.4 mm	4 mm	0.5 mm
Copper	0.3 mm	5 mm	0.5 mm
Aluminum & Zinc	0.7 mm	7 mm	0.65 mm
Lead	2.0 mm		2.0 mm

Table 47. Comparison of BS 6651 and IEC 62305 natural roof air-terminations.

20. British Standards (continued)

Down-conductor sizing	BS 6651	IEC 62305
Copper - tape	50 mm ² (min 20 x 2.5 mm)	50 mm ² (min 2 mm thick)
Copper - round	50 mm ² (8 mm dia)	50 mm ² (8 mm dia)
Copper - stranded		50 mm ²
Aluminum - tape	50 mm ² (min 20 x 2.5 mm)	70 mm ² (min 3 mm thick)
Aluminum - round	50 mm ² (8 mm dia)	50 mm ² (8 mm dia)
Aluminum - stranded		50 mm ²

Table 48. Comparison of BS 6651 and IEC 62305 down-conductor requirements.

20.2. BS EN 62305-2 COMPARED TO IEC/EN 62305-2

BS EN 62305-2 (Risk Management) is the British National Standard version of IEC/EN 62305-2. The British version has additional national annexes NB, NC, NH and NK. Annexes NB & NC provide values of probability of damage and assessment of losses that are more appropriate for the United Kingdom. Annex NH is a reworked (and corrected) examples of IEC/EN annexes B, C & H where values more appropriate to United Kingdom are used. Annex NK introduces the alternative tolerable risk values (as alternatives to Table 7, Section 5.4 of the standard). The values of both are compared in **Table 49** below. Annex NK also includes a British Isles ground flash density map and world thunderday map.

Types of Loss	IEC / EN 62305-2 R _T (y ⁻¹)	BS EN 62305-2 R _T (y ⁻¹)
Loss of human life or permanent injuries	10 ⁻⁵	10 ⁻⁵
Loss of service to the public	10 ⁻³	10 ⁻⁴
Loss of cultural heritage	10 ⁻³	10 ⁻⁴

Table 49. Comparison of tolerable losses between BS EN 62305-2 and IEC/EN 62305-2.

The alternative tolerable risk values have the effect of increasing the likelihood that lightning protection is required and/ or increasing the lightning protection level required. One could propose that the United Kingdom places a greater importance on cultural heritage and public services.

It should be noted in IEC/EN 62305-2 that Table 7 (tolerable risk levels) is provided as representative values, with the advice given that it is the responsibility of the authority having jurisdiction to identify the value of the tolerable risk. The British Standard lightning protection committee recommend that the values provided in table NK.1 are used in the UK.

21. IEC Design Standard

21. IEC DESIGN STANDARD AND EN COMPONENT STANDARD CONFLICTS

The IEC 62305-3 design standard details material requirements for conductors, air-terminals and earthing materials. The EN 50164-2 standard details test requirements for these standards. Unfortunately there are some small conflicts in tolerances between these standards, meaning that worst case values should be used where compliance with both standards is required (i.e., within CENELEC member countries).

Our powerful portfolio of brands:

CADDY ERICO HOFFMAN RAYCHEM SCHROFF
TRACER



[nVent.com/ERICO](https://www.nVent.com/ERICO)

WARNING. nVent products shall be installed and used only as indicated in nVent's product instruction sheets and training materials. Instruction

sheets are available at nVent.com/ERICO and from your nVent customer service representative. Improper installation, misuse, misapplication or other failure to completely follow nVent's instructions and warnings may cause product malfunction, property damage, serious bodily injury and death and/or void your warranty.

©2018 nVent. ©2018 nVent. All nVent marks and logos are owned or licensed by nVent Services GmbH or its affiliates. All other trademarks are the property of their respective owners. nVent reserves the right to change specifications without notice.

ERICO-TH-E907W-E696LT10WWEN-EN-1805