



HVAC Good Duct Design

2

**Professional Development Hours (PDH)
or
Continuing Education Hours (CE)**

Online PDH or CE course

Table of Contents

INTRODUCTION	3
WHY DUCT DESIGN IS IMPORTANT	3
DUCT DESIGN OBJECTIVES	3
SUPPLY DUCT SYSTEMS	4
RETURN DUCT SYSTEMS	5
DUCT MATERIALS	6
DUCT AND REGISTER LOCATIONS	7
DUCT DESIGN METHOD	8
DESIGN RECOMMENDATIONS AND KEY DESIGN ELEMENTS	9

INTRODUCTION

Central heating and cooling systems use an air distribution or duct system to circulate heated and/or cooled air to all the conditioned rooms in a house. Properly designed duct systems can maintain uniform temperatures throughout the house, efficiently and quietly.

WHY DUCT DESIGN IS IMPORTANT

The efficiency of air distribution systems has been found to be 60-75% or less in many houses because of insufficient and/or poorly installed duct insulation and leaks in the duct system. Properly designed and installed duct systems can have efficiencies of 80% or more for little or no additional cost, potentially saving a homeowner \$50-200 or more per year in heating and cooling costs. Moreover, efficient duct system designs can reduce equipment size, further saving money for new or replacement equipment.

Duct systems that leak and/or do not distribute air properly throughout the house may make some rooms too hot and others too cold. Leaky and unbalanced duct systems may force conditioned air outside and unconditioned air into the house. This increases heating and cooling costs and may also draw humidity, dust, mold spores, and other contaminants into a home from the attic, crawlspace, or garage and radon gas from the soil. In extreme cases, poorly designed and installed duct systems can induce backdrafting—spillage of flue gases from combustion appliances (e.g., furnace, water heater, fireplace) into the living space— primarily when atmospheric or natural-draft flues are used rather than powered combustion systems.

Duct systems that are undersized, are pinched, or have numerous bends and turns may lead to low air flow rates and high air velocities. Low air flow rates cause the heating and cooling equipment to operate inefficiently. High air velocities increase noise.

DUCT DESIGN OBJECTIVES

The objectives of good duct design are occupant comfort, proper air distribution, economical heating and cooling system operation, and economical duct installation. The outcome of the duct design process will be a duct system (supply and return plenums, ducts, fittings, boots, grilles, and registers) that

- Provides conditioned air to meet all room heating and cooling loads.
- Is properly sized so that the pressure drop across the air handler is within manufacturer and design specifications.
- Is sealed to provide proper air flow and to prevent air from entering the house or duct system from polluted zones.
- Has balanced supply and return air flows to maintain a neutral pressure in the house.

- Minimizes duct air temperature gains or losses between the air handler and supply outlets, and between the return register and air handler.

SUPPLY DUCT SYSTEMS

Supply ducts deliver air to the spaces that are to be conditioned. The two most common supply duct systems for residences are the trunk and branch system and the radial system because of their versatility, performance, and economy. The spider and perimeter loop systems are other options.

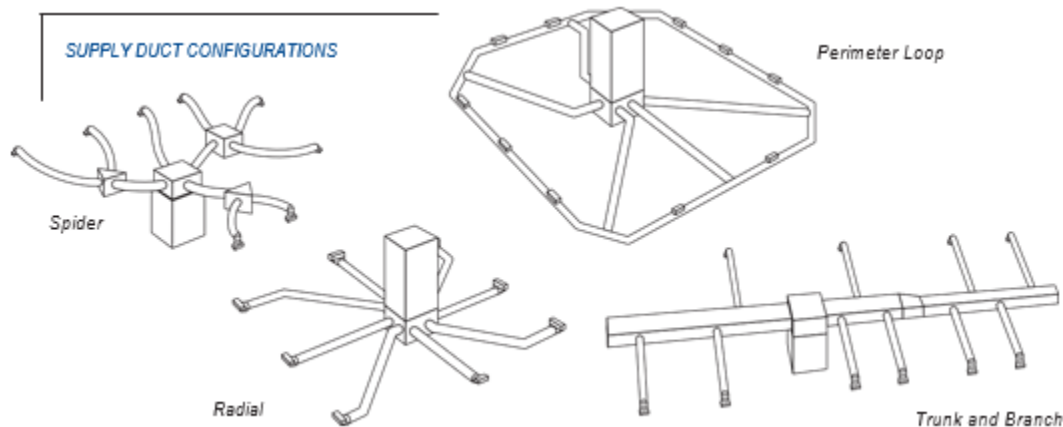

TRUNK AND BRANCH SYSTEM

In the trunk and branch system, a large main supply trunk is connected directly to the air handler or its supply plenum and serves as a supply plenum or an extension to the supply plenum. Smaller branch ducts and runouts are connected to the trunk. The trunk and branch system is adaptable to most houses, but it has more places where leaks can occur. It provides air flows that are easily balanced and can be easily designed to be located inside the conditioned space of the house.

There are several variations of the trunk and branch system. An extended plenum system uses a main supply trunk that is one size and is the simplest and most popular design. The length of the trunk is usually limited to about 24 feet because otherwise the velocity of the air in the trunk gets too low and air flow into branches and runouts close to the air handler becomes poor. Therefore, with a centrally located air handler, this duct system can be installed in homes up to approximately 50 feet long. A reducing plenum system uses a trunk reduction periodically to maintain a more uniform pressure and air velocity in the trunk, which improves air flow in branches and runouts closer to the air handler. Similarly, a reducing trunk system reduces the cross-sectional area of the trunk after every branch duct or runout, but it is the most complex system to design.

SPIDER SYSTEM

A spider system is a more distinct variation of the trunk and branch system. Large supply trunks (usually large-diameter flexible ducts) connect remote mixing boxes to a small, central supply plenum. Smaller branch ducts or runouts take air from the remote mixing boxes to the individual supply outlets. This system is difficult to locate within the conditioned space of the house.

RADIAL SYSTEM

In a radial system, there is no main supply trunk; branch ducts or runouts that deliver conditioned air to individual supply outlets are essentially connected directly to the air handler, usually using a small supply plenum. The short, direct duct runs maximize air flow. The radial system is most adaptable to single-story homes. Traditionally, this system is associated with an air handler that is centrally located so that ducts are arranged in a radial pattern. However, symmetry is not mandatory, and designs using parallel runouts can be designed so that duct runs remain in the conditioned space (e.g., installed above a dropped ceiling).

PERIMETER LOOP SYSTEM

A perimeter loop system uses a perimeter duct fed from a central supply plenum using several feeder ducts. This system is typically limited to houses built on slab in cold climates and is more difficult to design and install.

Return Air Techniques

Closed interior doors create a return-air blockage in systems with only one or two returns. Grilles through doors or walls or jumper ducts can reduce house pressures and improve circulation.

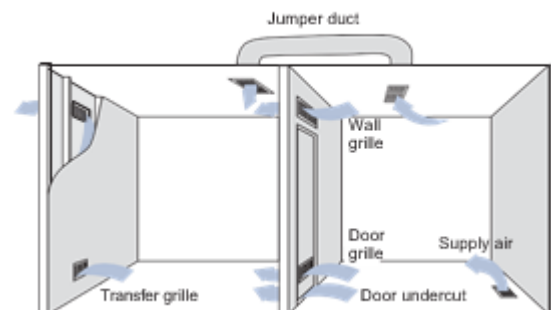

RETURN DUCT SYSTEMS

Return ducts remove room air and deliver it back to the heating and cooling equipment for filtering and reconditioning. Return duct systems are generally classified as either central or multiple-room return.

MULTIPLE - ROOM RETURN SYSTEM

A multiple-room return system is designed to return air from each room supplied with conditioned air, especially those that can be isolated from the rest of the house (except bathrooms and perhaps kitchens and mechanical rooms). When properly designed and installed, this is the ultimate return duct system because it ensures that air flow is returned from all rooms (even with

doors closed), minimizes pressure imbalances, improves privacy, and is quiet. However, design and installation costs of a multi-room return system are generally higher than costs for a central return system, and higher friction losses can increase blower requirements.

CENTRAL RETURN SYSTEM

A central return system consists of one or more large grilles located in central areas of the house (e.g., hallway, under stairway) and often close to the air handler. In multi-story houses, a central return is often located on each floor. To ensure proper air flow from all rooms, especially when doors are closed, transfer grilles or jumper ducts must be installed in each room (undercutting interior doors to provide 1 inch of clearance to the floor is usually not sufficient by itself).

Transfer grilles are through-the-wall vents that are often located above the interior door frames, although they can be installed in a full wall cavity to reduce noise transmission. The wall cavity must be well sealed to prevent air leakage. Jumper ducts are short ducts routed through the ceiling to minimize noise transfer.

DUCT MATERIALS

Air distribution ducts are commonly constructed from sheet metal, rigid fiberglass duct board, or flexible nonmetallic duct. Selection of duct material is based on price, performance, and installation requirements.

Designs that use the house structure or building framing (e.g., building cavities, closets, raised-floor air handler plenums, platform returns, wall stud spaces, panned floor joists) as supply or return ducts can be relatively inexpensive to install. However, they should be avoided because they are difficult to seal and cannot always be insulated. In addition, because such systems tend to be rough and have many twists and turns, it is difficult to design them so as to ensure good air distribution. Even return plenums built under a stairway or in a closet, for example, should be avoided if a completely ducted system is possible.

SHEET METAL

Sheet metal is the most common duct material and can be used on most all supply and return duct applications (for plenums, trunks, branches, and runouts). Sheet metal ducts have a smooth interior surface that offers the least resistance to air flow. When located in an unconditioned space, they must be insulated with either an interior duct liner or exterior insulation. They must also be carefully and completely sealed during construction/installation, using approved tapes or preferably mastic, because each connection, joint, and seam has potential leakage. Screws should be used to mechanically fasten all joints.

FIBERGLASS DUCT BOARD

Fiberglass duct board is insulated and sealed as part of its construction. It is usually used to form rectangular supply and return trunks, branches, and plenums, although it can be used for runouts as well. Connections should be mechanically fastened using shiplap or V-groove joints and

stapling and sealed with pressure-activated tapes and mastic. Fiberglass duct board provides excellent sound attenuation, but its longevity is highly dependent on its closure and fastening systems.

FLEXIBLE NONMETALLIC DUCT

Flexible nonmetallic duct (or flex duct) consists of a duct inner liner supported on the inside by a helix wire coil and covered by blanket insulation with a flexible vapor-barrier jacket on the outside. Flex duct is often used for runouts, with metal collars used to connect the flexible duct to supply plenums, trunks, and branches constructed from sheet metal or duct board. Flex duct is also commonly used as a return duct. Flex duct is factory-insulated and has fewer duct connections and joints. However, these connections and joints must be mechanically fastened using straps and sealed using mastic. Flex duct is easily torn, crushed, pinched, or damaged during installation. It has the highest resistance to air flow. Consequently, if used, it must be properly specified and installed.

DUCT AND REGISTER LOCATIONS

Locating the air handler unit and air distribution system inside the conditioned space of the house is the best way to improve duct system efficiency and is highly recommended. With this design, any duct leakage will be to the inside of the house. It will not significantly affect the energy efficiency of the heating and cooling system because the conditioned air remains inside the house, although air distribution may suffer. Also, ducts located inside the conditioned space need minimal insulation (in hot and humid climates), if any at all. The cost of moving ducts into the conditioned space can be offset by smaller heating and cooling equipment, smaller and less duct work, reduced duct insulation, and lower operating costs.

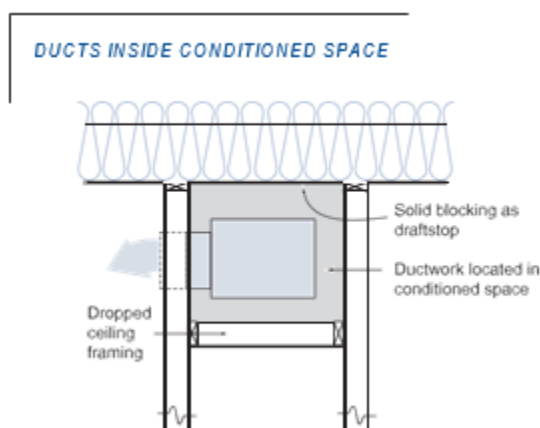

There are several methods for locating ducts inside the conditioned space.

- Place the ducts in a furred-down chase below the ceiling (e.g., dropped ceiling in a hallway), a chase furred-up in the attic, or other such chases. These chases must be specially constructed, air-sealed, and insulated to ensure they are not connected

to unconditioned spaces.

- Locate ducts between the floors of a multi-story home (run through the floor trusses or joists). The exterior walls of these floor cavities must be insulated and sealed to ensure they are within the conditioned space. Holes in the cavity for wiring, plumbing, etc., must be sealed to prevent air exchange with unconditioned spaces.
- Locate ducts in a specially-constructed sealed and insulated crawlspace (where the walls of the crawlspace are insulated rather than the ceiling).

Ducts should not be run in exterior walls as a means of moving them into the conditioned space because this reduces the amount of insulation that can be applied to the duct and the wall itself. A supply outlet is positioned to mix conditioned air with room air and is responsible for most of the air movement within a room. Occupant comfort requires that supply register locations be carefully selected for each room. In cold climates, perimeter floor outlets that blanket portions of the exterior wall (usually windows) with supply air are generally preferred. However, in today's better insulated homes, the need to locate outlets near the perimeter where heat loss occurs is becoming less important. In hot climates, ceiling diffusers or high wall outlets that discharge air parallel to the ceiling are typically installed. In moderate climates, outlet location is less critical. Outlet locations near interior walls can significantly reduce duct lengths (decreasing costs), thermal losses (if ducts are located outside the conditioned space), and blower requirements. To prevent supply air from being swept directly up by kitchen, bathroom, or other exhaust fans, the distance between supply registers and exhaust vents should be kept as large as possible.

The location of the return register has only a secondary effect on room air motion. However, returns can help defeat stratification and improve mixing of room air if they are placed high when cooling is the dominant space-conditioning need and low when heating is dominant. In multi-story homes with both heating and cooling, upper-level returns should be placed high and lower-level returns should be placed low. Otherwise, the location of the return register can be determined by what will minimize duct runs, improve air circulation and mixing of supply air, and impact other considerations such as aesthetics.

DUCT DESIGN METHOD

The air distribution system should be designed at the same time the house plans are being developed, following the procedures in the Air Conditioning Contractors of America's (ACCA's) Manual D: Residential Duct Systems. Planning locations for ductwork, structural framing, plumbing, and electrical wiring simultaneously avoids conflicts between these systems.

The following eight steps should be followed in the design of an air distribution system to ensure efficiency and comfort:

1. Select the general type of heating and cooling equipment (e.g., furnace, heat pump, air conditioner). The heating and cooling equipment should be selected based on occupant preferences, availability of different fuels (e.g., natural gas,

- electricity), installation costs, and operating costs.
2. Select the general type of air distribution system (supply and return duct systems). The general designs and duct materials for the supply and return duct systems should be selected after considering the type of equipment selected and its location, the local climate, the architectural and structural features of the house, zoning requirements, and installation and operating costs. ACCA's Manual G: Selection of Distribution Systems and Manual RS: Comfort, Air Quality, and Efficiency by Design can assist in this selection.
 3. Calculate the design heating and cooling loads of each room of the house and the loads that are associated with the entire house using ACCA's Manual J: Residential Load Calculation (eighth edition). Room loads are used to determine the air flow needed for each room, and the house loads are used to size and select specific heating and cooling equipment models.
 4. Size and select the specific models of the heating and cooling equipment using ACCA's Manual S: Residential Equipment Selection. This precedes the duct sizing calculations because, in residential applications, the blower (fan) data of the selected equipment establish the duct design criteria. In addition, identify any component or device (e.g., filter, humidifier, electric resistance heater, cooling coil) that was not included when the blower data and their associated pressure drops were developed.
 5. Develop a scale drawing or rough sketch of the air distribution system showing the location of the air handling equipment, supply outlets, return openings, loads and air flow rates associated with each supply and return register, location of duct runs, lengths of straight duct runs, fitting types, and equivalent lengths of the fittings. Be sure to account for the direction of joists, roof hips, and other potential obstructions such as two-story foyers or rooms.
 6. Determine the size of all the ducts based on the room loads, blower data, pressure drops of additional components or devices, and equivalent duct lengths following the procedures in ACCA's Manual D: Residential Duct Systems. Several duct layouts may need to be examined before reaching a final design.
 7. Select and size the air distribution system devices (return grilles and supply air diffusers, grilles, and registers) using ACCA's Manual T: Air Distribution Basics for Residential and Small Commercial Buildings. These must be selected to maintain air velocities below values that will cause noise but, in the case of supply outlets, sufficiently high so that air is disbursed to exterior walls or ceilings as desired.
 8. Select the insulation levels for the duct system in accordance with the 2000 International Energy Conservation Code.

DESIGN RECOMMENDATIONS AND KEY DESIGN ELEMENTS

In designing the air distribution using ACCA's Manual D: Residential Duct Systems, consider

the following recommendations before finalizing the design:

- Design the air distribution system to be located inside the conditioned space of the house to the greatest extent possible. Do not locate ducts in exterior walls.
- The entire air distribution system should be “hard” ducted, including returns (i.e., building cavities, closets, raised-floor air handler plenums, platform returns, wall stud spaces, panned floor joists, etc., should not be used).
- In two-story and very large houses, consider using two or more separate heating and cooling systems, each with its own duct system. In two-story homes, for example, upper stories tend to gain more heat in summer and lose more heat in winter, so the best comfort and performance is often achieved by using separate systems for the upper and lower stories.
- Consider supply outlet locations near interior walls to reduce duct lengths.
- Locate supply outlets as far away from exhaust vents as possible in bathrooms and kitchens to prevent supply air from being swept directly up by the exhaust fans.
- Consider installing volume dampers located at the takeoff end of the duct rather than at the supply register to facilitate manual balancing of the system after installation. Volume dampers should have a means of fixing the position of the damper after the air distribution system is balanced.
- When using a central return system, include (a) a return on each level of a multi-story house, (b) a specification to install transfer grilles or jumper ducts in each room with a door (undercutting interior doors to allow 1 inch of clearance to the floor is usually not sufficient), and (c) if at all possible, a return in all rooms with doors that require two or more supply ducts.
- Specify higher duct insulation levels in ducts located outside the conditioned space than those specified by the 2000 International Energy Conservation Code, especially when variable-speed air handling equipment is being used. Lower air flows provided by variable-speed heating and cooling systems to improve operating efficiency increase the resident time of air within the air distribution system, which in turn increases thermal losses in the winter and thermal gains in the summer. Attic insulation placed over ducts helps where it is possible.
- Specify that all duct joints must be mechanically fastened and sealed prior to insulation to prevent air leakage, preferably with mastic and fiberglass mesh. Consider testing of ducts using a duct blower to ensure that the air distribution system is tight, especially if ducts are unavoidably located in an unconditioned space. A typical requirement is that duct leakage (measured using a duct blower in units of cubic feet per minute when the ducts are pressurized to 25 Pascals) should not exceed 5% of the system air flow rate.