



This Land Surveying course has been developed by
Failure & Damage Analysis, Inc.

www.DiscountPDH.com

CHAPTER 4

EARTHWORK

Section I. PLANNING OF EARTHWORK OPERATIONS

IMPORTANCE

In road, railroad, and airfield construction, the movement of large volumes of earth (earthwork) is one of the most important construction operations. It requires a great amount of engineering effort.

The planning, scheduling, and supervising of earthwork operations are of major importance in obtaining an efficiently operated construction project. To plan a schedule, the quantities of clearing, grubbing, and stripping, as well as the quantities and positions of cuts and fills, must be known. Then, the most efficient type and number of pieces of earthmoving equipment can be chosen, the proper number of personnel assigned, and the appropriate time allotted.

Earthwork computations involve the calculation of volumes or quantities, the

determination of final grades, the balancing of cuts and fills, and the planning of the most economical haul of material. The surveyor uses field notes and established grade to plot the cross sections at regular stations and at any plus stations which may have been established at critical intermediate points. The line representing the existing ground surface and those lines representing the proposed cut or fill enclose cross-section areas. The surveyor uses these areas and the measured distances along the centerline to compute earthwork volumes.

CROSS SECTIONS

The cross section used in earthwork computations is a vertical section. It is perpendicular to the centerline at full and plus stations and represents the boundaries

of a proposed or existing cut or fill. Typical cross sections for a roadbed are illustrated in figure 4-1.

The determination of cross-section areas is simplified when the sections are plotted on cross-section paper. This is usually done to the same vertical and horizontal scale, standard practice being 1 inch equals 10 feet.

However, if the vertical cut or fill is small in comparison with the width, the surveyor may use an exaggerated vertical scale to gain additional precision in plotting such sections.

The surveyor must take care, however, when computing areas of this type of plotted section that the proper area is obtained. For example, a 1 inch equals 10 foot scale, both vertical and

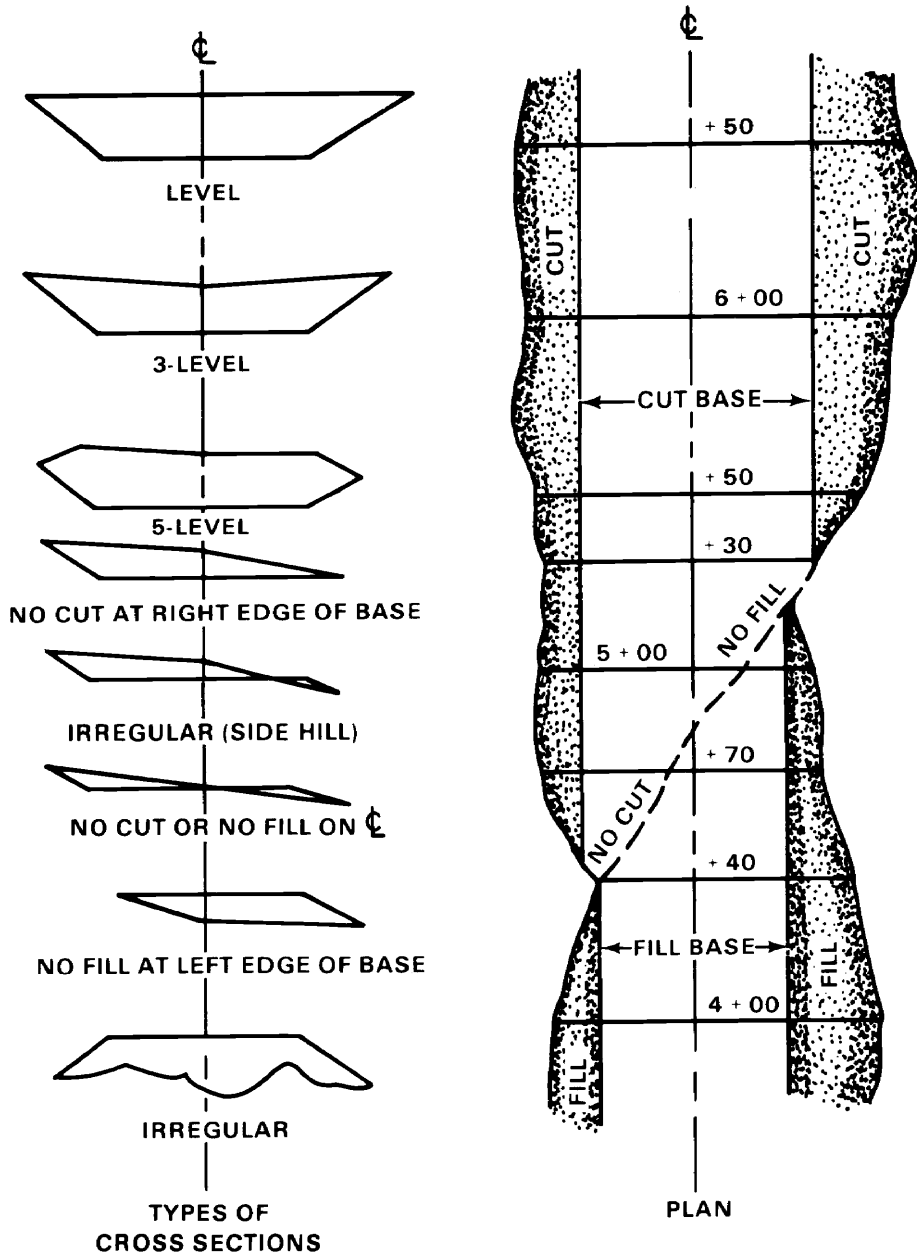
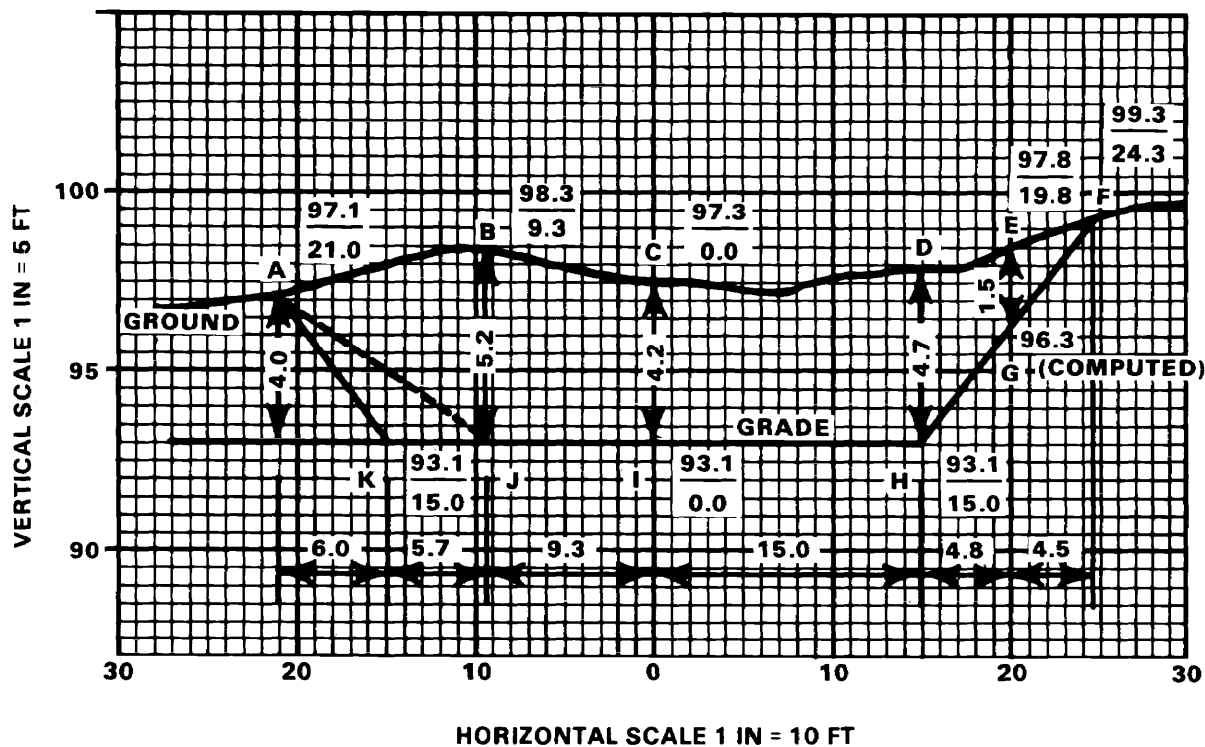

Figure 4-1. Typical cross sections

horizontal, yields 100 square feet, but 1 inch equals 10 foot horizontal and 1 inch equals 2 foot vertical yields only 20 square feet. An exaggerated vertical scale is used in figure 4-2 to illustrate a five-level section.

The side slopes of a cross section are expressed by a ratio of horizontal distance to vertical distance. A 1 1/2:1 side slope indicates a slope extending 1 1/2 feet horizontally per foot of vertical rise or fall. Slopes may be inclined

more or less sharply than this, such as 3:1, 2:1, or 1:1. The surveyor usually determines the slope by the design specifications based on the stability of the soil in cut or fill. However, the need for economy in construction operations must often be considered. For example, cut slopes may be flattened more than is required by soil characteristics solely to produce enough material for a nearby fill. This practice is more economical than operating a borrow pit to obtain this material.



AREA = 175.0 SQ FT BY COUNTING SQUARES
 AREA = 170.5 SQ FT BY TRAPEZOIDS AND TRIANGLES

Figure 4-2. Area of irregular cross sections

Section II. AREAS

AREA COMPUTATION

The surveyor can determine cross-section areas for construction earthwork volumes by one of the following methods: the counting squares method, the geometric method (geometry of trapezoids and triangles), the stripper method, or the double-meridian-distance method. The stripper and counting-

squares methods are simple and give approximate results, while the other methods give results as accurate as the cross-section field data will permit. Standard practice requires that cut and fill areas of a cross section, where both occur simultaneously, be determined separately.

Counting-Squares Method

To make a hasty approximation of a cross-section area plotted on cross-section paper, count the number of squares enclosed by the boundary lines of the section. Then multiply the total number of counted squares by the number of square feet represented by a single square.

For example, the cross section in figure 4-2 encloses approximately 350 1/10-inch squares or 3.5 1-inch squares. The scales of the cross section indicate that one 1/10-inch square represents 1 foot horizontally and 6 inches vertically, or one half of a square foot in area. Therefore, the approximate area of the cross section is 350 divided by 2 equals 175 square feet. Using the 1-inch square, which represents 10 feet horizontally and 5 feet vertically or 50 square feet in area, the cross-section area is approximately 3.5 x 50 = 175 square feet.

Geometric Method

To compute the area of a cross section by the geometric method, sometimes called the trapezoidal method, subdivide the area into simple geometrical figures, calculate each area according to its geometry, and total the results. There is no set rule for performing the subdivisions. The computer selects those subdivisions which will produce the most direct and accurate results. Figure 4-3a illustrates the subdivision of a typical three-level section into five triangles. Figure 4-3b illustrates the subdivision of a five-level section into two triangles and two trapezoids. The following computations apply to the geometric method in figure 4-2. Basic formulas are as follows.

$$A = \frac{bh}{2} \text{ (area of a triangle)}$$

$$A = h \frac{(b_1 + b_2)}{2} \text{ (area of a trapezoid)}$$

A = area; b, b₁, and b₂ = the lengths of the bases; and h = the perpendicular distance, or height, between parallel bases for a trapezoid and from base to vertex for a triangle.

	square feet
2A of triangle AJK = 5.7 x 4.0	= 22.8
2A of triangle ABJ = 5.2 (5.7+ 6.0)	= 60.8
2A of trapezoid BCIJ = 9.3 (5.2+ 4.2)	= 87.4
2A of trapezoid CDHI = 15.0 (4.2+ 4.7)	= 133.5
2A of trapezoid DEGH = 4.8 (4.7+ 1.5)	= 29.8
2A of triangle EFG = 1.5 x 4.5	= 6.8
Total (double area of AFHK)	<u>= 341.1</u>

Area of the cross section = 341.1 ÷ 2 = 170.5

Note that the computation is simplified by adding all the numerical products for triangles and trapezoids together and then dividing the total by 2. The dashed line, AJ, is added to subdivide quadrilateral ABJK into two triangles, AJK and ABJ.

Stripper Method

To determine the area of a plotted cross section by strip measurements, subdivide the area into strips by vertical lines spaced at regular intervals. Measure the total length of these lines by cumulatively marking the length of each line along the edge of a stripper made of paper or plastic. Then, multiply the cumulative total of the average base lengths by the width of the strip. Regular

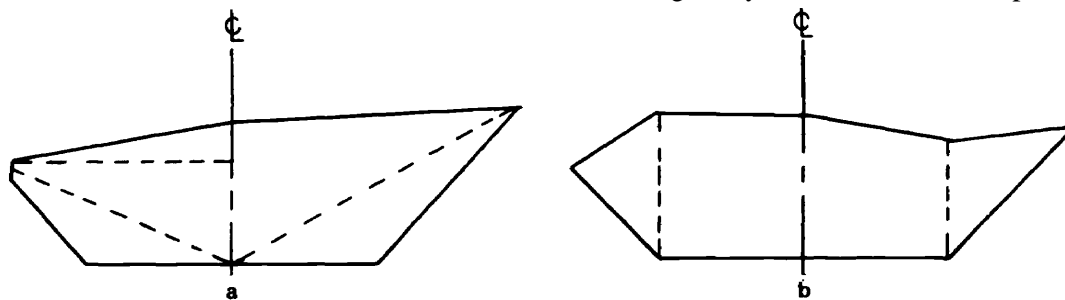
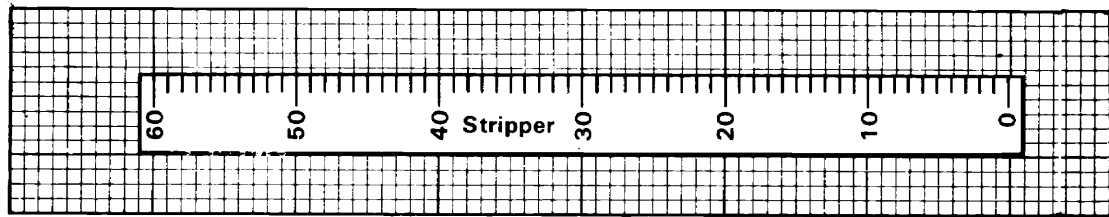

Figure 4-3. Subdividing cross sections

intervals of 3, 5, or 10 feet, depending upon the roughness of the ground, give satisfactory results for strip widths. Due regard must be

given to the horizontal and vertical scales of the cross section. The procedure is illustrated in figure 4-4.



A

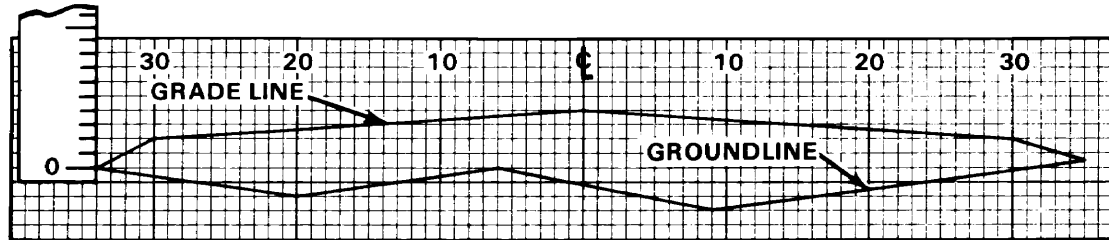

B

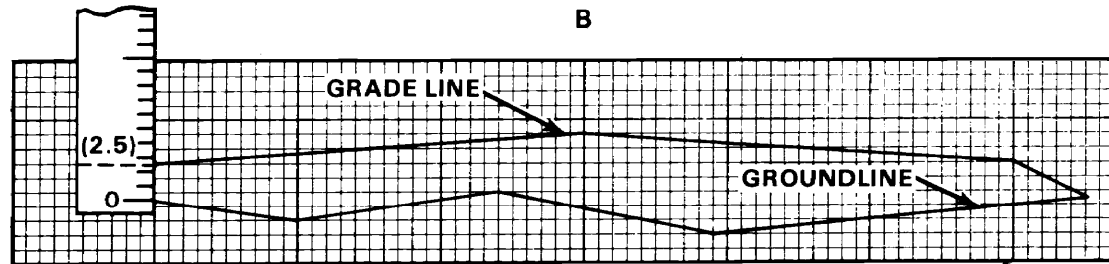

C

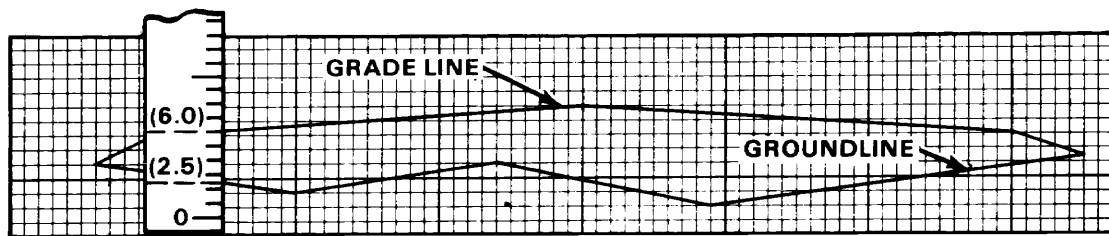

D

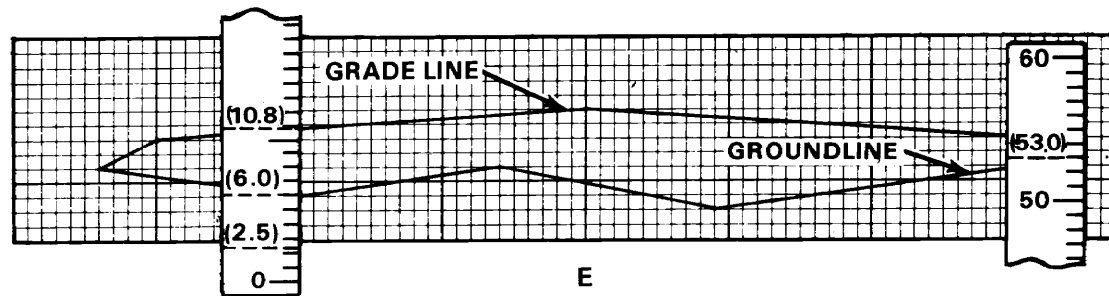

E

Figure 4-4. Cross-section area by stripper method

The stripper shown is 5 squares wide by 60 squares long. Its zero index is placed at the intersection of the ground and side-slope line of the section.

The stripper is moved an interval of 5 squares to the right with zero reading at the bottom. It is then moved another 5 squares to the right with the previous top reading (2.5) now adjacent to the bottom line. The stripper is again moved 5 squares to the right for another interval with the previous top reading (6.0) adjacent to the bottom line.

This process of moving 5 squares to the right and bringing the top reading to the bottom line is continued until the stripper reaches the right edge of the cross section with a final reading of 53.0. Multiply this last reading (53.0) by the strip width used (5) to get the number of squares in the section (265.0). To find the area of the cross section in square feet, multiply the number of squares by the area in square feet of one square.

Double-Meridian-Distance Method

The double-meridian-distance (DMD) method gives a more precise value for a cross-section area than the stripper method. It does, however, involve more effort and time. It is essential that the elevations (latitudes) and the distance from the centerline (departures) of all points on the cross section be known.

The method is based on the theory that the area of a right triangle equals one half of the product of the two sides. Since latitudes and departures are at right angles to each other, the area bounded by the distance, the latitude, and the departure is a right angle. The surveyor can determine this area by taking one half of the product of the latitude and the departure. However, depending on its location, the triangle may add to or subtract from the total area of the irregular figure.

To avoid determining a plus or minus area for each triangle, a slight refinement is made. The departure is added twice. It is first added when determining the DMD of the course and

second, when determining the next course's DMD. Multiplying the DMD of each course by its latitude results in twice the area, but the sign of this product illustrates whether the area adds to or subtracts from the figure area.

A step-by-step procedure to work out a DMD area is given below and illustrated in figure 4-5.

- (1) Compute and record all the latitudes and departures.
- (2) Select the far left station (D) as the first point and D-E as the first course to avoid negative areas in the DMD.
- (3) The DMD of the first course equals the departure of the course itself, 4.0.
- (4) The DMD of any other course (E-F) equals the DMD of the preceding course (D-E) plus the departure of the preceding course (D-E) and the departure of the course (E-F) itself or $4.0 + 4.0 + 30.0 = 38.0$. For the next course (F-I), the same procedure is followed. Add together the DMD of the preceding course, the departure of the preceding course, and the departure of the course itself, or $38.0 + 30.0 + 30.0 = 98.0$.
- (5) The DMD of the last course is numerically equal to its departure but with the opposite sign (+14.0).
- (6) Multiply each DMD value by its latitude. Positive products are entered under north double areas and negative products under south double areas.
- (7) The sum of all north double areas minus the sum of all the south double areas, DISREGARDING THE SIGNS, equals twice the cross-section areas. Divide this double area by 2 to get the true cross-section area.

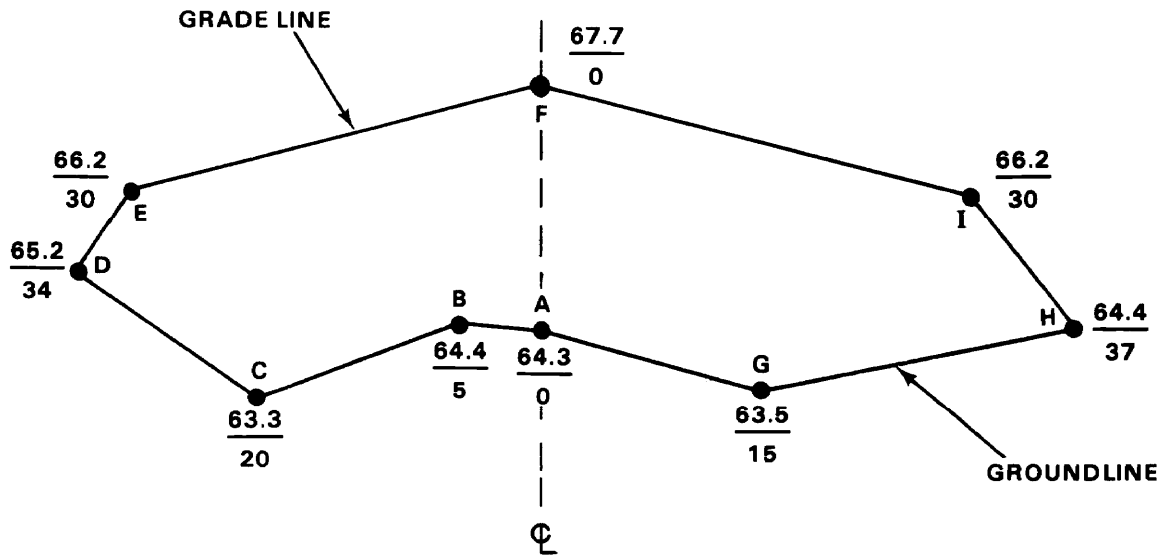

COURSE	LATITUDE	DEPARTURE	D.M.D.	NORTH Double Area (+)	SOUTH Double Area (-)
D-E	+1.0	+4.0	4.0	4.0	
E-F	+1.5	+30.0	38.0	57.0	
F-I	-1.5	+30.0	98.0		147.0
I-H	-1.8	+7.0	135.0		243.0
H-G	-0.9	-22.0	120.0		108.0
G-A	+0.8	-15.0	83.0	66.4	
A-B	+0.1	-5.0	63.0	6.3	
B-C	-1.1	-15.0	43.0		47.3
C-D	+1.9	-14.0	14.0	26.6	
				<u>+160.3</u>	<u>-545.3</u>
Difference = $545.3 - 160.3 = 385.0$ Area: $385.0/2 = 192.5 \text{ ft}^2$					

Figure 4-5. Cross-section area by double-meridian-distance method

AREA BY PLANIMETER

The surveyor uses a polar planimeter to measure the area of a plotted figure. There are two types of planimeters. One has a fixed scale, and one has an adjustable scale. Basically, the surveyor uses both in the same way, with the exception that the fixed scale cannot be adjusted to yield a 1:1 ratio when tracing areas.

Operation

The planimeter (figure 4-6) touches the paper at four points: the anchor point (B), the tracing point (A), the drum (C), and the support wheel (G). The adjustable tracing arm (E) is graduated to permit adjustment to the scale of the plotted figure. This adjustment provides a direct ratio between the area traced by the tracing point and the revolutions of the roller. The scale screws, F1, F2, and F3, are used to accomplish the proper adjustment of the tracing arm scale. Proper scale settings are provided with each instrument. If the scale setting provided yields an area that is too large, the scale reading must be increased and vice versa.

As the planimeter encircles the area to be measured, the drum (C) revolves and records the answer in tens and hundreds. A vernier (M) is mounted adjacent to the drum and

enables a single unit (ones) reading. The disk (D) is attached to the drum by a worm gear, counting the number of drum revolutions and giving the thousands reading. The surveyor must first read the disk for thousands, then the drum for hundreds and tens, and finally, the vernier for single units (ones).

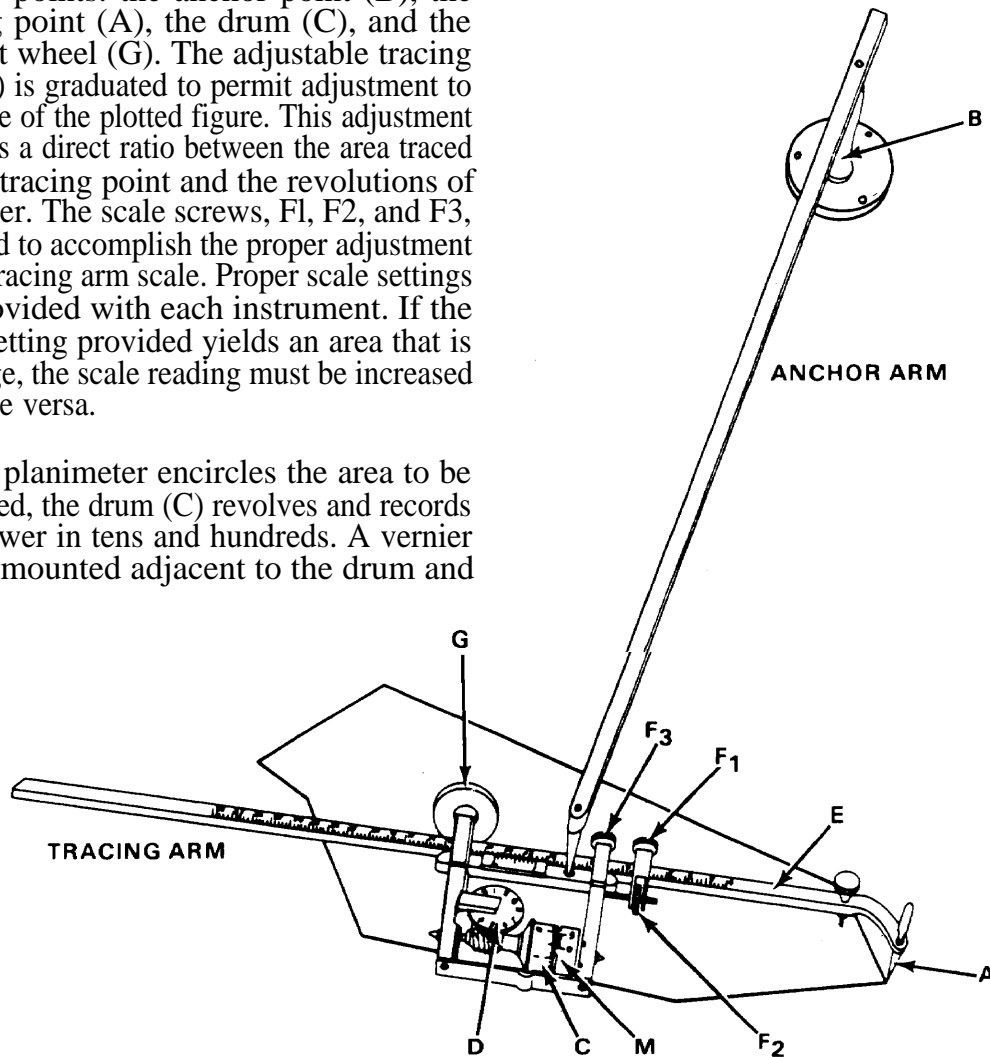

Figure 4-6. Polar planimeter

Procedures

The following are rules for using a planimeter,

- Always measure cut and fill areas separately.
- Check the accuracy of the planimeter as a measuring device to guard against errors due to temperature changes and other noncompensating factors. A simple method of testing its consistency of operation is to trace an area of 1 square inch with the arm set for a 1:1 ratio. The disk, drum, and vernier combined should read 1.000 for this area.
- Before measuring a specific area, determine the scale of the plot and set the adjustable arm of the planimeter according to the chart in the planimeter case. Check the setting by carefully tracing a known area, such as five large squares on the cross-section paper, and verifying the reading on the disk, drum, and vernier. If the reading is inconsistent with the known area, readjust the arm settings until a satisfactory reading is obtained.
- To measure an area, set the anchor point of the adjusted planimeter at a convenient position outside the plotted area; place the tracing point on a selected point on the perimeter of the cross section; take an initial reading from the disk, drum, and vernier; continue tracing the perimeter clockwise, keeping the tracing point carefully on the line being followed; and when the tracing point closes on the initial point, again take a reading from the disk, drum, and vernier. The difference between the initial reading and the final reading gives a value proportional to the area being traced.
- Make two independent measurements of the area to insure accurate results. Make the second measurement with the tracing point placed at a point on the opposite side of the first measurement. This procedure gives two compensating readings. The mean of these readings is more accurate than either one individually.
- To measure plotted areas larger than the capacity of the planimeter, divide the areas into sections and measure each separately.

Section III. EARTH AND ROCK EXCAVATION

CLASSES OF EXCAVATED MATERIAL

Excavated material is usually classified as common excavation, loose rock, and solid rock. Although classifying excavation material is not a survey function, the surveyor must differentiate among the different types so excavation records will match the construction work. When performing surveys to determine quantities of excavated materials, the surveyor must record common excavation, loose-rock excavation, and solid-rock excavation data separately in the field notes.

Common excavation involves the moving of earth or of earth with detached boulders less than one-half cubic yard in volume. Loose-rock excavation involves the moving of consolidated materials which have been loosened without blasting with picks, bars, or simple air and mechanical devices. Solid-rock excavation involves the moving of rock from solid beds or the breaking up of boulders measuring 1 cubic yard or more by means of explosives.

BORROW PITS

When there is an imbalance in the volume of cuts and fills in construction projects, it is often necessary to borrow the required fill dirt from borrow pits outside the construction limits but near the fill site. Any time the haul distance between the last available dirt and the fill site becomes too far, it is cheaper to establish a borrow pit.

Under some circumstances, it is not necessary to survey borrow pits. However, it is often necessary to buy the fill dirt. The surveyor must determine how much earth was removed from the borrow pit. This can be done by establishing a grid over the area to be excavated. The grid can be at any convenient interval (for example, 10-, 25-, 50-, or 100-foot squares).

Once the grid is staked, the surveyor can determine the elevation of each grid corner by leveling. The volume of earth that has

been removed can be computed at any time by reestablishing the grid corners and determining their new elevation. The surveyor does this by subtracting the average elevation of the grid corners after excavation from the average elevation of the same grid corners before excavation and multiplying the difference by the number of square feet in the grid square.

When laying out the grid, the surveyor must lay out two baselines parallel to two adjacent sides of the grid for use in reestablishing the grid. The surveyor should place them far enough outside the area of excavation to avoid destruction but close enough to be convenient. (See figure 4-7.)

The surveyor should treat waste areas or dumps where excess material is deposited in the same manner as borrow pits, with the exception that the volume to be measured is the volume deposited, not excavated.

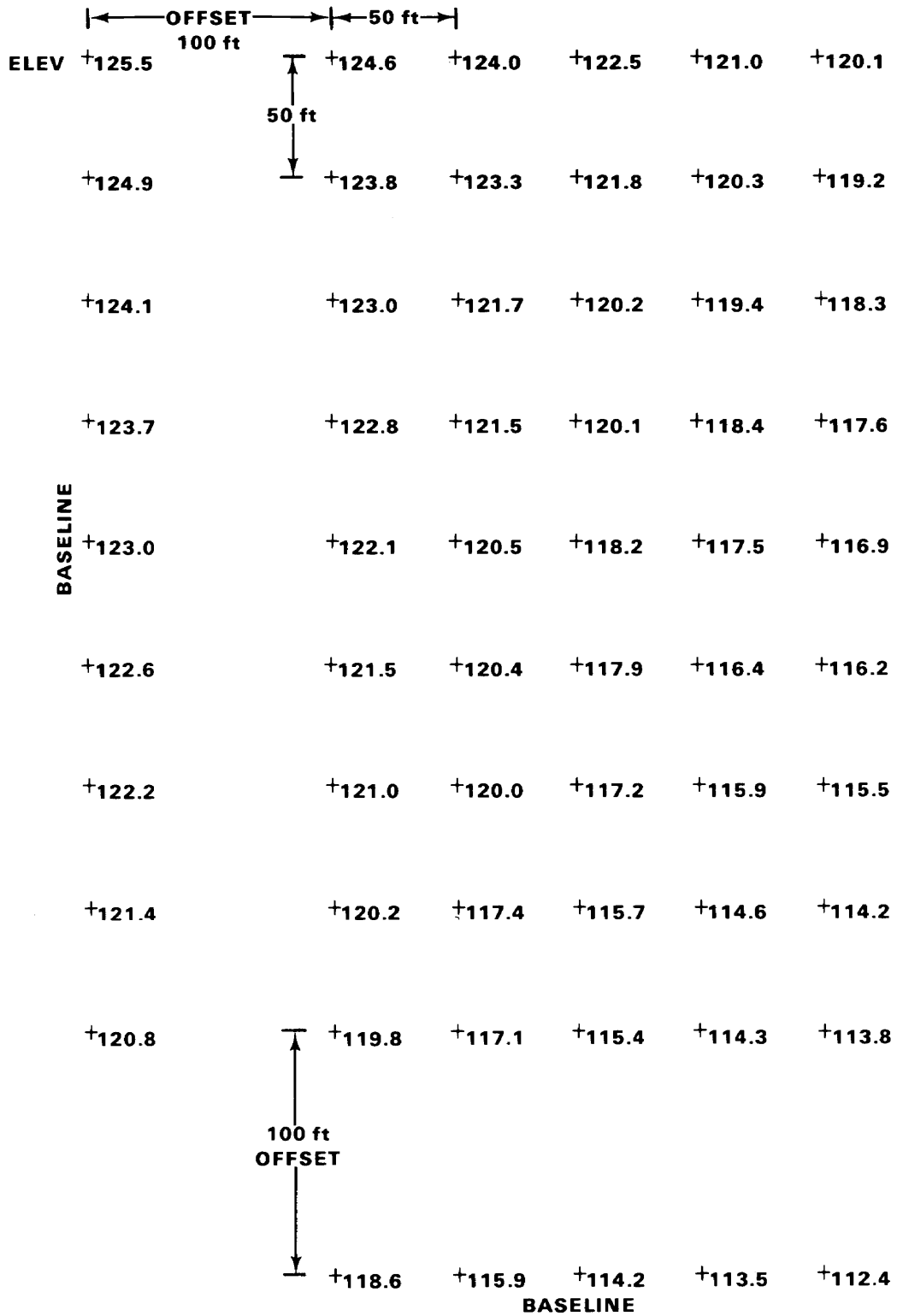

Figure 4-7. Typical grid layout for borrow pits